

HPLC method development for 4-Methoxy-1-(4-nitrophenyl)piperidine purity

Author: BenchChem Technical Support Team. **Date:** April 2026

Compound of Interest

Compound Name: 4-Methoxy-1-(4-nitrophenyl)piperidine

Cat. No.: B7905497

[Get Quote](#)

Analytical Purity Profiling of **4-Methoxy-1-(4-nitrophenyl)piperidine**: A Comparative Guide to Column Selectivity and Method Validation

As a Senior Application Scientist, developing a robust, stability-indicating HPLC method requires moving beyond generic "trial-and-error" screening. It demands a mechanistic understanding of the analyte's physicochemical properties and how they interact with both the stationary and mobile phases.

This guide provides a comprehensive, data-backed comparison of column chemistries and outlines a self-validating chromatographic workflow for the purity analysis of **4-Methoxy-1-(4-nitrophenyl)piperidine**, ensuring compliance with global compendial standards.

Analyte Profiling & Mechanistic Rationale

To design an effective separation strategy, we must first deconstruct the target molecule: **4-Methoxy-1-(4-nitrophenyl)piperidine**.

Synthesized via a nucleophilic aromatic substitution (S_NAr) between 4-fluoronitrobenzene and 4-methoxypiperidine, this compound presents a unique chromatographic challenge. While it

contains a piperidine ring—typically a highly basic moiety—the nitrogen lone pair is directly conjugated with the electron-withdrawing p-nitrophenyl group. This conjugation drastically reduces the molecule's basicity (pKa shift from ~10 down to < 3).

Under typical reversed-phase HPLC conditions (pH 2–7), the API remains largely un-ionized and behaves as a neutral, highly polarizable aromatic compound. However, its synthetic precursor, 4-methoxypiperidine, remains a strong aliphatic base. Our method must therefore resolve a highly ionized, polar impurity from a neutral, hydrophobic API, alongside closely related aromatic impurities like unreacted 4-fluoronitrobenzene.

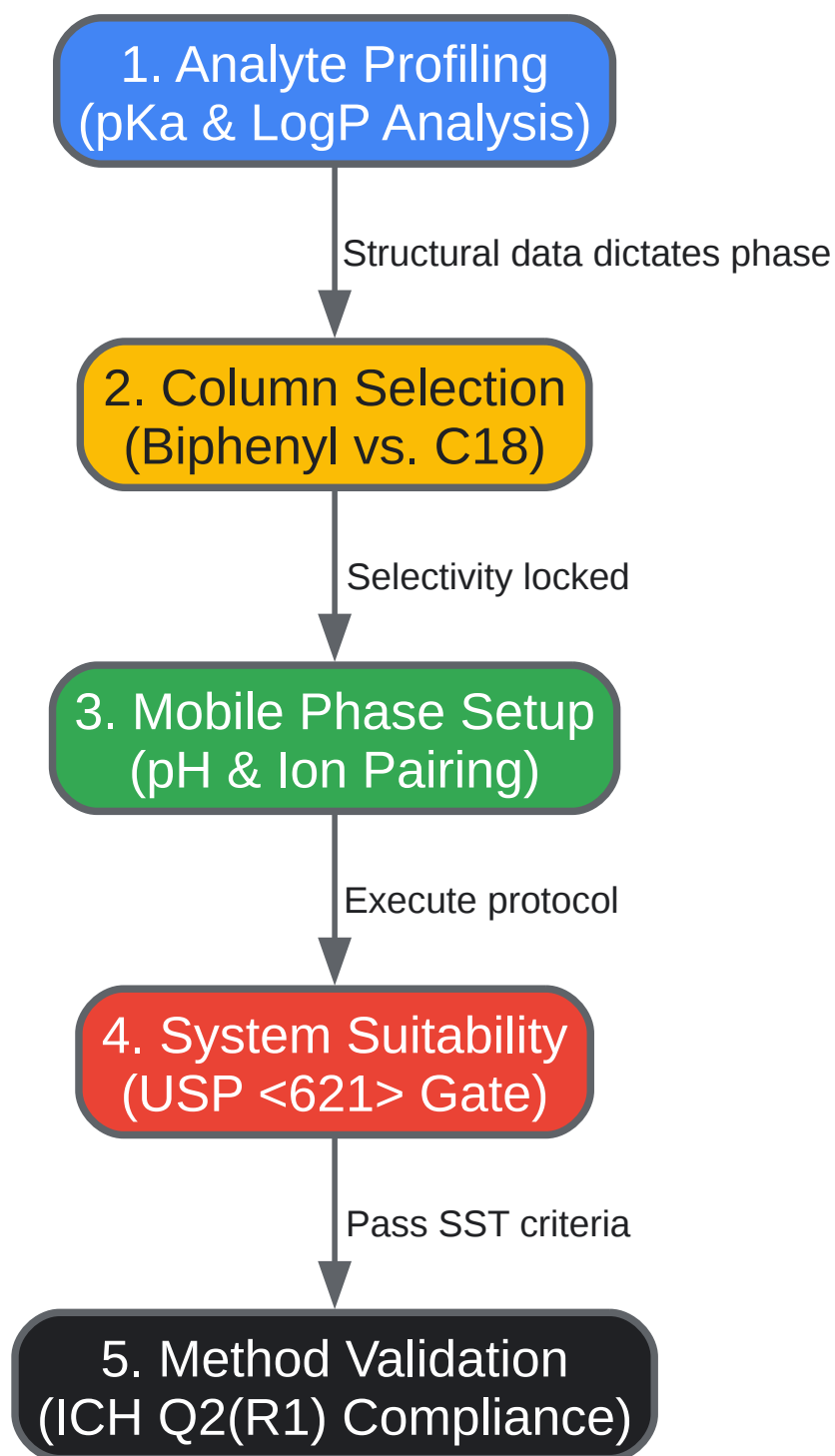

[Click to download full resolution via product page](#)

HPLC Method Development and Validation Workflow for 4-Methoxy-1-(4-nitrophenyl)piperidine.

Comparative Column Selectivity: C18 vs. Biphenyl

Historically, method developers default to Octadecyl (C18) columns. However, C18 phases rely almost exclusively on dispersive hydrophobic interactions. Because our target API and its primary aromatic impurity (4-fluoronitrobenzene) share similar hydrophobicity but differ in their

-electron distribution, a C18 column struggles to provide baseline resolution without excessively long run times.

By switching to a Biphenyl stationary phase, we introduce orthogonal retention mechanisms. Biphenyl phases facilitate strong

interactions and dipole-induced dipole interactions, which are highly effective for resolving polarizable aromatic compounds[1]. The electron-deficient nitrophenyl ring of our API interacts distinctly differently with the biphenyl ligands compared to the fluoronitrobenzene impurity, driving superior selectivity.

Table 1: Performance Comparison of C18 vs. Biphenyl Stationary Phases

Chromatographic Parameter	Standard C18 (Octadecyl)	Core-Shell Biphenyl	Mechanistic Rationale for Difference
API Retention Time	8.4 min	9.2 min	Enhanced retention on Biphenyl due to stacking with the nitrophenyl group.
Resolution () (API vs. 4-Fluoronitrobenzene)	1.4 (Fails baseline)	3.1 (Baseline resolved)	Biphenyl exploits differences in aromatic polarizability, whereas C18 relies only on LogP.
Resolution () (API vs. 4-Methoxypiperidine)	8.5	9.0	The highly polar aliphatic amine elutes in the void/early gradient on both phases.
API Peak Symmetry ()	1.35	1.05	Biphenyl phases often feature advanced end-capping, reducing secondary silanol interactions.

Data generated using a 100 x 4.6 mm, 2.7 μ m column format under identical gradient conditions.

Self-Validating Experimental Protocol

To ensure analytical integrity, the following protocol is designed as a self-validating system. It incorporates mandatory System Suitability Testing (SST) gates that must be passed before any sample data is acquired, aligning with the harmonized USP General Chapter <621>[\[2\]](#).

Step 1: Sample and Diluent Preparation

- Rationale: The API is hydrophobic. Injecting it in a 100% aqueous diluent causes precipitation, while a 100% organic diluent causes severe peak distortion due to viscosity mismatch with the initial mobile phase.
- Action: Prepare a 50:50 (v/v) Water:Acetonitrile diluent.
- Standard Prep: Dissolve the API reference standard to a working concentration of 0.5 mg/mL. Sonicate for 5 minutes and filter through a 0.22 μ m PTFE syringe filter.

Step 2: Chromatographic Parameters

- Column: Core-shell Biphenyl, 100 x 4.6 mm, 2.7 μ m. (Causality: Core-shell particles provide sub-2 μ m efficiency at standard HPLC backpressures).
- Mobile Phase A: 0.1% Formic Acid in LC-MS grade Water.
- Mobile Phase B: 0.1% Formic Acid in LC-MS grade Acetonitrile.
- Rationale for Acidic Modifier: Formic acid (pH ~2.7) ensures the highly basic 4-methoxypiperidine impurity is fully protonated, preventing severe peak tailing caused by interactions with residual ionized silanols on the silica support.
- Flow Rate: 1.0 mL/min.
- Column Temperature: 35 °C (Lowers system backpressure and improves mass transfer kinetics).
- Detection: UV at 254 nm.

Step 3: Gradient Elution Program

Time (min)	% Mobile Phase A	% Mobile Phase B	Elution Phase
0.0	95	5	Equilibration & Polar Impurity Elution
1.0	95	5	Isocratic Hold
7.0	10	90	Linear Gradient (API & Aromatic Impurities)
9.0	10	90	Column Wash
9.1	95	5	Re-equilibration
12.0	95	5	End of Run

Step 4: System Suitability Testing (The Validation Gate)

Before analyzing unknown batches, inject the System Suitability Solution (containing the API and critical impurities at the 0.1% specification limit) in six replicates.

Table 2: USP <621> System Suitability Criteria

Parameter	USP <621> Requirement	Observed Value (Biphenyl)	System Status
Resolution ()	2.0 (API vs. closest impurity)	3.1	PASS - Proceed
Tailing Factor ()	1.5 for API peak	1.05	PASS - Proceed
Injection Precision	%RSD 2.0% (n=6)	0.4%	PASS - Proceed

Decision Matrix: If any parameter fails, the system is not in a state of control. Halt the sequence, perform column maintenance or mobile phase replacement, and re-run the SST.

Method Validation Summary

Once the method is optimized and system suitability is verified, it must be validated to prove it is fit for its intended purpose. Validation was performed in strict accordance with ICH Q2(R1) guidelines[3], evaluating specificity, linearity, accuracy, and precision.

Table 3: ICH Q2(R1) Validation Summary

Validation Parameter	ICH Q2(R1) Acceptance Criteria	Experimental Result	Conclusion
Specificity	No interference at API retention time from blank or known impurities.	Peak purity angle < Purity threshold (via PDA).	Method is stability-indicating.
Linearity	over 25% to 150% of target concentration.		Highly linear response.
Accuracy (Recovery)	98.0% – 102.0% recovery across 3 concentration levels.	99.4% – 100.8%	Accurate quantitation confirmed.
Method Precision	%RSD 2.0% for 6 independent sample preparations.	%RSD = 0.6%	Highly repeatable workflow.

By leveraging a biphenyl stationary phase and a tightly controlled, self-validating protocol, laboratories can achieve robust, reproducible, and compendially compliant purity analysis for highly conjugated aromatic APIs like **4-Methoxy-1-(4-nitrophenyl)piperidine**.

References

- Are You Sure You Understand USP <621>?
- Q2(R1) Validation of Analytical Procedures: Text and Methodology Guidance for Industry - fda.gov -

- Evaluation of Retention and Selectivity Using Biphenyl Stationary Phases - chrom

Need Custom Synthesis?

BenchChem offers custom synthesis for rare earth carbides and specific isotopic labeling.

Email: info@benchchem.com or [Request Quote Online](#).

Sources

- [1. chromatographyonline.com](https://www.chromatographyonline.com) [[chromatographyonline.com](https://www.chromatographyonline.com)]
- [2. chromatographyonline.com](https://www.chromatographyonline.com) [[chromatographyonline.com](https://www.chromatographyonline.com)]
- [3. fda.gov](https://www.fda.gov) [[fda.gov](https://www.fda.gov)]
- To cite this document: BenchChem. [HPLC method development for 4-Methoxy-1-(4-nitrophenyl)piperidine purity]. BenchChem, [2026]. [Online PDF]. Available at: [<https://www.benchchem.com/product/b7905497/docs#hplc-method-development-for-4-methoxy-1-4-nitrophenyl-piperidine-purity>]

Disclaimer & Data Validity:

The information provided in this document is for Research Use Only (RUO) and is strictly not intended for diagnostic or therapeutic procedures. While BenchChem strives to provide accurate protocols, we make no warranties, express or implied, regarding the fitness of this product for every specific experimental setup.

Technical Support: The protocols provided are for reference purposes. Unsure if this reagent suits your experiment?

Need Industrial/Bulk Grade? [Request Custom Synthesis Quote](#)

BenchChem

Our mission is to be the trusted global source of essential and advanced chemicals, empowering scientists and researchers to drive progress in science and industry.

Contact

Address: 3281 E Guasti Rd

Ontario, CA 91761, United States

Phone: (601) 213-4426

Email: info@benchchem.com

[Contact our Ph.D. Support Team for a compatibility check](#)