

# Application Notes and Protocols for Tricopper Phosphide in Oxygen Evolution Reaction (OER)

**Author:** BenchChem Technical Support Team. **Date:** April 2026

## Compound of Interest

Compound Name: *Tricopper phosphide*

CAS No.: 12134-35-9

Cat. No.: B079733

[Get Quote](#)

For Researchers, Scientists, and Drug Development Professionals

These application notes provide a comprehensive overview of the use of **tricopper phosphide** ( $\text{Cu}_3\text{P}$ ) as an efficient and cost-effective electrocatalyst for the oxygen evolution reaction (OER) in water splitting. The following sections detail the synthesis of  $\text{Cu}_3\text{P}$  nanomaterials, standardized protocols for electrochemical evaluation, and a summary of their catalytic performance.

## Introduction to Tricopper Phosphide for OER

The electrochemical splitting of water into hydrogen and oxygen is a promising strategy for clean energy production. However, the sluggish kinetics of the anodic OER often limit the overall efficiency of this process. Noble metal oxides, such as  $\text{IrO}_2$  and  $\text{RuO}_2$ , are the current state-of-the-art catalysts for OER, but their high cost and scarcity hinder their large-scale application. Consequently, there is a significant research effort to develop efficient OER electrocatalysts based on earth-abundant elements.

**Tricopper phosphide** ( $\text{Cu}_3\text{P}$ ) has emerged as a promising non-noble metal-based electrocatalyst for OER due to its unique electronic structure, high conductivity, and excellent catalytic activity, particularly in alkaline media.[1][2] Nanostructured  $\text{Cu}_3\text{P}$ , such as nanowires and nanosheets, provides a large surface area with abundant active sites, further enhancing its performance.[3][4][5] This document provides detailed protocols for the synthesis and electrochemical evaluation of  $\text{Cu}_3\text{P}$  for OER applications.

## Performance Data of $\text{Cu}_3\text{P}$ -based OER Electrocatalysts

The OER performance of various  $\text{Cu}_3\text{P}$ -based electrocatalysts is summarized in the table below. Key performance metrics include the overpotential required to achieve a current density of  $10 \text{ mA/cm}^2$  ( $\eta@10$ ), the Tafel slope, and the operational stability. A lower overpotential and Tafel slope indicate higher catalytic activity.

Electrocatalyst	Substrate	Electrolyte	Overpotential @ $10 \text{ mA/cm}^2$ (mV)	Tafel Slope (mV/dec)	Stability
$\text{Cu}_3\text{P}$ Nanowires	Copper Foam (CF)	1.0 M KOH	327 (at $20 \text{ mA/cm}^2$ )	Not Reported	Stable for 22 hours at $20 \text{ mA/cm}^2$ [3][4]
$\text{Cu}_3\text{P}$ Nanosheets	Nickel Foam (NF)	1.0 M KOH	~320	54	Not specified[5][6]
$\text{Cu}_3\text{P}$ Nanobush	Copper Mesh	1.0 M KOH	380	Not Reported	Stable after 1000 CV cycles[7][8]
$\text{Cu}_3\text{P}$ Nanoparticles	Glassy Carbon	Not Specified	450	63	Stable[9]
$\text{Cu}_3\text{P/NiO@NF}$	Nickel Foam (NF)	1 M KOH	310	88	Stable for 20 hours at $10 \text{ mA/cm}^2$ [10]

## Experimental Protocols

# Synthesis of Self-Supported Cu<sub>3</sub>P Nanowires on Copper Foam

This protocol describes a two-step method for the synthesis of self-supported Cu<sub>3</sub>P nanowires on copper foam (Cu<sub>3</sub>P NWs/CF), adapted from the literature.<sup>[3][4]</sup>

### Materials:

- Copper foam (CF)
- Potassium hydroxide (KOH)
- Sodium hypophosphite (NaH<sub>2</sub>PO<sub>2</sub>)
- Deionized (DI) water
- Ethanol
- Acetone

### Equipment:

- Electrochemical workstation (potentiostat)
- Three-electrode electrochemical cell
- Graphite rod (counter electrode)
- Saturated calomel electrode (SCE) or Ag/AgCl electrode (reference electrode)
- Tube furnace with gas flow control
- Quartz tube
- Beakers, graduated cylinders, and other standard laboratory glassware

### Procedure:

### Step 1: Preparation of $\text{Cu}(\text{OH})_2$ Nanowire Precursor on Copper Foam ( $\text{Cu}(\text{OH})_2$ NWs/CF)

- Cut the copper foam into desired dimensions (e.g., 1 cm x 2 cm).
- Clean the copper foam by sonicating in acetone, ethanol, and DI water for 15 minutes each to remove surface impurities.
- Set up a three-electrode electrochemical cell with the cleaned copper foam as the working electrode, a graphite rod as the counter electrode, and a reference electrode.
- Use a 1.0 M KOH solution as the electrolyte.
- Perform electrodeposition of  $\text{Cu}(\text{OH})_2$  nanowires onto the copper foam by applying a constant potential or current. Note: The specific electrochemical conditions (potential, current density, and time) should be optimized based on the desired nanowire morphology.
- After electrodeposition, rinse the  $\text{Cu}(\text{OH})_2$  NWs/CF thoroughly with DI water and dry it in an oven at 60°C.

### Step 2: Phosphating of $\text{Cu}(\text{OH})_2$ NWs/CF to form $\text{Cu}_3\text{P}$ NWs/CF

- Place the dried  $\text{Cu}(\text{OH})_2$  NWs/CF in the center of a quartz tube in a tube furnace.
- Place a crucible containing sodium hypophosphite ( $\text{NaH}_2\text{PO}_2$ ) upstream of the  $\text{Cu}(\text{OH})_2$  NWs/CF in the quartz tube.
- Purge the tube with a high-purity inert gas (e.g.,  $\text{N}_2$  or Ar) for at least 30 minutes to remove any oxygen.
- Heat the furnace to a specific temperature (e.g., 250-350°C) under the inert gas flow and hold for a designated time (e.g., 1-2 hours) to allow for the phosphating reaction to occur.
- After the reaction, allow the furnace to cool down to room temperature naturally under the inert gas flow.
- The resulting self-supported  $\text{Cu}_3\text{P}$  nanowires on copper foam ( $\text{Cu}_3\text{P}$  NWs/CF) are ready for characterization and electrochemical testing.

## Electrochemical Evaluation of OER Performance

This standardized protocol outlines the electrochemical measurements for evaluating the OER performance of the prepared Cu<sub>3</sub>P electrocatalyst.[\[11\]](#)[\[12\]](#)[\[13\]](#)

Materials and Equipment:

- Electrochemical workstation (potentiostat)
- Three-electrode electrochemical cell
- Prepared Cu<sub>3</sub>P catalyst on its substrate (working electrode)
- Platinum (Pt) wire or graphite rod (counter electrode)
- Hg/HgO or Ag/AgCl electrode (reference electrode)
- 1.0 M KOH electrolyte
- Inert gas (N<sub>2</sub> or Ar) for purging

Procedure:

- **Electrolyte Preparation:** Prepare a 1.0 M KOH solution using high-purity KOH and DI water.
- **Cell Assembly:** Assemble the three-electrode cell with the Cu<sub>3</sub>P catalyst as the working electrode, a Pt wire or graphite rod as the counter electrode, and a suitable reference electrode. Ensure the working electrode is fully immersed in the electrolyte.
- **Electrolyte Purging:** Purge the electrolyte with an inert gas (N<sub>2</sub> or Ar) for at least 30 minutes before the measurement to remove dissolved oxygen. Maintain a gentle stream of the inert gas over the electrolyte during the measurements.
- **Reference Electrode Calibration:** Calibrate the reference electrode against a reversible hydrogen electrode (RHE). All measured potentials should be converted to the RHE scale using the Nernst equation:  $E(\text{RHE}) = E(\text{ref}) + E^\circ(\text{ref}) + 0.059 * \text{pH}$ .

- **Cyclic Voltammetry (CV) Conditioning:** Perform several CV cycles in the potential window of interest (e.g., 1.0 to 1.7 V vs. RHE) at a scan rate of 50-100 mV/s to activate and stabilize the catalyst surface.
- **Linear Sweep Voltammetry (LSV) for OER Activity:** Record the OER polarization curve using LSV at a slow scan rate (e.g., 5 or 10 mV/s) to minimize capacitive currents. The potential range should cover the onset of OER and extend to a potential where a significant current density is achieved.
- **iR Correction:** Measure the solution resistance ( $R_s$ ) using electrochemical impedance spectroscopy (EIS) and apply iR correction to the LSV data to obtain the intrinsic catalytic activity. The corrected potential is calculated as  $E_{\text{corrected}} = E_{\text{measured}} - i * R_s$ .
- **Tafel Plot Analysis:** Determine the Tafel slope by plotting the overpotential ( $\eta = E_{\text{corrected}} - 1.23 \text{ V}$ ) against the logarithm of the current density ( $\log(j)$ ). The Tafel slope is the slope of the linear region of this plot and provides insight into the OER mechanism.
- **Electrochemical Impedance Spectroscopy (EIS):** Perform EIS at a specific overpotential in the OER region to investigate the charge transfer kinetics. The resulting Nyquist plot can be fitted to an equivalent circuit to determine the charge transfer resistance ( $R_{ct}$ ).
- **Chronoamperometry or Chronopotentiometry for Stability Test:** Evaluate the long-term stability of the catalyst by holding it at a constant potential (chronoamperometry) or a constant current density (chronopotentiometry) for an extended period (e.g., 10, 20, or more hours) and monitoring the current or potential change over time.

## Visualized Workflows and Mechanisms

The following diagrams, generated using Graphviz, illustrate the experimental workflow for preparing and testing  $\text{Cu}_3\text{P}$  electrocatalysts and the proposed logical relationship for its OER activity.

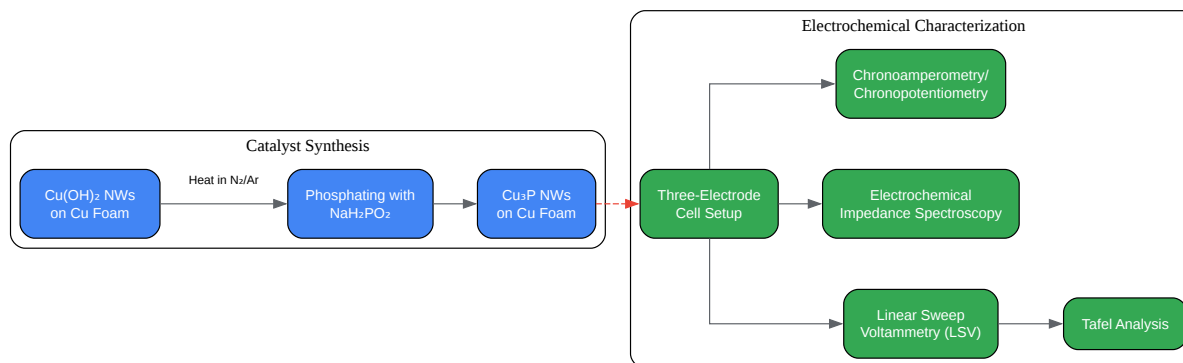

[Click to download full resolution via product page](#)

Caption: Experimental workflow for  $\text{Cu}_3\text{P}$  nanowire synthesis and OER characterization.

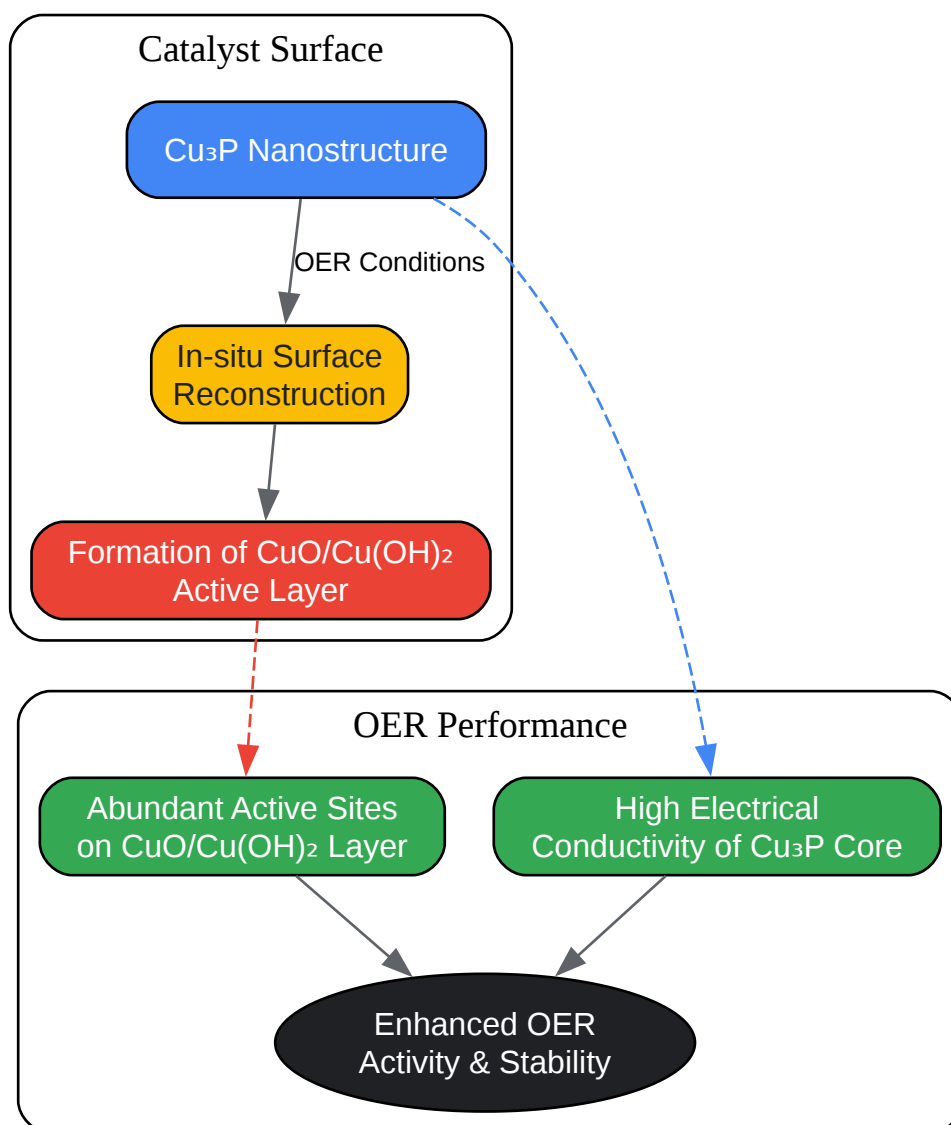

[Click to download full resolution via product page](#)

Caption: Proposed mechanism for the OER activity of  $\text{Cu}_3\text{P}$  electrocatalysts.

## Conclusion

**Tricopper phosphide** has demonstrated significant potential as a low-cost, earth-abundant electrocatalyst for the oxygen evolution reaction. The nanostructured forms of  $\text{Cu}_3\text{P}$ , particularly self-supported architectures, exhibit enhanced performance due to their high surface area and improved charge transport properties. The protocols provided herein offer a standardized approach for the synthesis and electrochemical evaluation of  $\text{Cu}_3\text{P}$ -based OER catalysts, facilitating further research and development in the field of electrochemical water splitting. The

underlying mechanism is believed to involve the in-situ formation of a copper oxide/hydroxide active layer on the conductive  $\text{Cu}_3\text{P}$  core, which synergistically enhances the OER activity.

### Need Custom Synthesis?

BenchChem offers custom synthesis for rare earth carbides and specific isotopic labeling.

Email: [info@benchchem.com](mailto:info@benchchem.com) or [Request Quote Online](#).

## References

- [1. mdpi.com \[mdpi.com\]](#)
- [2. researchgate.net \[researchgate.net\]](#)
- [3. Self-supported  \$\text{Cu}\_3\text{P}\$  nanowire electrode as an efficient electrocatalyst for the oxygen evolution reaction - RSC Advances \(RSC Publishing\) \[pubs.rsc.org\]](#)
- [4. Self-supported  \$\text{Cu}\_3\text{P}\$  nanowire electrode as an efficient electrocatalyst for the oxygen evolution reaction - PMC \[pmc.ncbi.nlm.nih.gov\]](#)
- [5. pubs.acs.org \[pubs.acs.org\]](#)
- [6. researchgate.net \[researchgate.net\]](#)
- [7. pubs.acs.org \[pubs.acs.org\]](#)
- [8. researchgate.net \[researchgate.net\]](#)
- [9. researchgate.net \[researchgate.net\]](#)
- [10. researchgate.net \[researchgate.net\]](#)
- [11. Frontiers | Protocol for Screening Water Oxidation or Reduction Electrocatalyst Activity in a Three-Electrode Cell for Alkaline Exchange Membrane Electrolysis \[frontiersin.org\]](#)
- [12. pubs.acs.org \[pubs.acs.org\]](#)
- [13. Recommended electrochemical measurement protocol for oxygen evolution reaction: Abstract, Citation \(BibTeX\) & Reference | Bohrium \[bohrium.com\]](#)
- To cite this document: BenchChem. [Application Notes and Protocols for Tricopper Phosphide in Oxygen Evolution Reaction (OER)]. BenchChem, [2026]. [Online PDF]. Available at: [<https://www.benchchem.com/product/b079733/docs#application-notes-and-protocols-for-tricopper-phosphide-in-oxygen-evolution-reaction-oer>]

**Disclaimer & Data Validity:**

The information provided in this document is for Research Use Only (RUO) and is strictly not intended for diagnostic or therapeutic procedures. While BenchChem strives to provide accurate protocols, we make no warranties, express or implied, regarding the fitness of this product for every specific experimental setup.

**Technical Support:** The protocols provided are for reference purposes. Unsure if this reagent suits your experiment?

**Need Industrial/Bulk Grade?** [Request Custom Synthesis Quote](#)

## BenchChem

Our mission is to be the trusted global source of essential and advanced chemicals, empowering scientists and researchers to drive progress in science and industry.

### Contact

Address: 3281 E Guasti Rd  
Ontario, CA 91761, United States  
Phone: (601) 213-4426  
Email: [info@benchchem.com](mailto:info@benchchem.com)

[Contact our Ph.D. Support Team for a compatibility check](#)