

A Comparative Guide to the Reactivity of Acetobromocellobiose and Acetobromoglucose in Glycosylation Reactions

Author: BenchChem Technical Support Team. **Date:** December 2025

Compound of Interest

Compound Name: Acetobromocellobiose

Cat. No.: B079220

[Get Quote](#)

For Researchers, Scientists, and Drug Development Professionals

This guide provides an objective comparison of the chemical reactivity of two key glycosyl donors: α -acetobromocellobiose and α -acetobromoglucose. The information presented herein, supported by experimental protocols and mechanistic diagrams, is intended to assist researchers in the strategic design and execution of complex carbohydrate syntheses.

Introduction to Glycosyl Donors

α -Acetobromoglucose (per-O-acetyl- α -D-glucopyranosyl bromide) and α -acetobromocellobiose (hepta-O-acetyl- α -D-cellobiosyl bromide) are fundamental building blocks in synthetic carbohydrate chemistry. As glycosyl bromides, they serve as electrophilic partners in glycosylation reactions, enabling the formation of glycosidic bonds. The choice between a monosaccharide and a disaccharide donor is contingent upon the synthetic target. Understanding their relative reactivity is paramount for optimizing reaction conditions and achieving desired yields and stereoselectivity.

Theoretical Comparison of Reactivity

The reactivity of these glycosyl donors in reactions such as the Koenigs-Knorr glycosylation is primarily influenced by steric and electronic factors.

- **Steric Hindrance:** **Acetobromocellobiose**, as a disaccharide, presents significantly greater steric bulk around the anomeric carbon (C-1) compared to the monosaccharide acetobromoglucose. This increased steric hindrance is expected to impede the approach of a nucleophilic glycosyl acceptor, thereby reducing the rate of glycosylation.
- **Electronic Effects:** The electron-withdrawing nature of the acetyl protecting groups is crucial for the stability and reactivity of the glycosyl bromide. These effects are largely comparable between the two molecules. The C-2 acetyl group in both donors can participate in the reaction mechanism through neighboring group participation, leading to the formation of a 1,2-trans glycosidic linkage.

Data Presentation: A Comparative Overview

While direct side-by-side kinetic studies are not readily available in the literature, a qualitative and illustrative comparison can be drawn from existing data and chemical principles. The following table summarizes the key differences and their expected impact on reactivity in a typical Koenigs-Knorr reaction.

Feature	α - Acetobromoglucose	α - Acetobromocellobiose	Expected Impact on Reactivity
Structure	Monosaccharide	Disaccharide	
Molecular Weight	~411.2 g/mol	~699.5 g/mol	
Steric Hindrance at C-1	Lower	Higher	The greater steric hindrance in acetobromocellobiose is anticipated to result in slower reaction rates compared to acetobromoglucose under identical conditions.
Solubility	Generally high in common organic solvents (e.g., CH ₂ Cl ₂ , CHCl ₃)	May exhibit slightly different solubility profiles, potentially requiring solvent optimization.	Variations in solubility can influence reaction kinetics.
Typical Promoters	Silver(I) oxide, silver(I) carbonate, mercury(II) cyanide	Silver(I) oxide, silver(I) carbonate, mercury(II) cyanide	Both donors are compatible with standard Koenigs-Knorr promoters.
Representative Reaction Time	Generally shorter (e.g., several hours to 24 hours)	Often requires longer reaction times (e.g., 24 to 48 hours) to achieve comparable yields due to lower reactivity.	
Illustrative Yields	High yields (often >80-90%) are achievable with simple alcohol acceptors.	Good yields are attainable, but may be moderately lower than for acetobromoglucose,	

particularly with
sterically demanding
acceptors.

Experimental Protocols

The following are representative experimental protocols for the Koenigs-Knorr glycosylation using acetobromoglucose and **acetobromocellobiose**.

Protocol 1: Synthesis of Methyl 2,3,4,6-tetra-O-acetyl- β -D-glucopyranoside from Acetobromoglucose

Materials:

- α -Acetobromoglucose (1.0 equiv)
- Methanol (excess, as solvent and reactant)
- Silver(I) oxide (Ag_2O) (1.0 equiv)
- Anhydrous calcium sulfate (Drierite)
- Dichloromethane (CH_2Cl_2)
- Celite

Procedure:

- A solution of α -acetobromoglucose in anhydrous dichloromethane is prepared in a round-bottom flask under an inert atmosphere (e.g., nitrogen or argon).
- Methanol is added to the solution.
- Anhydrous calcium sulfate is added to ensure anhydrous conditions.
- Silver(I) oxide is added to the stirred solution. The reaction mixture is protected from light.

- The reaction is stirred at room temperature for 24 hours. The progress of the reaction is monitored by thin-layer chromatography (TLC).
- Upon completion, the reaction mixture is filtered through a pad of Celite to remove insoluble silver salts. The filter cake is washed with dichloromethane.
- The combined filtrate is concentrated under reduced pressure.
- The resulting residue is purified by silica gel column chromatography to afford the pure methyl 2,3,4,6-tetra-O-acetyl- β -D-glucopyranoside.

Protocol 2: Synthesis of a Cellobioside Derivative from Acetobromocellobiose

Materials:

- α -Acetobromocellobiose (1.0 equiv)
- Glycosyl acceptor (e.g., a primary alcohol) (1.2 equiv)
- Silver(I) carbonate (Ag_2CO_3) (1.5 equiv)
- Anhydrous dichloromethane (CH_2Cl_2)
- Molecular sieves (4 Å)
- Celite

Procedure:

- A mixture of the glycosyl acceptor, silver(I) carbonate, and activated molecular sieves in anhydrous dichloromethane is stirred in a round-bottom flask under an inert atmosphere for 30 minutes at room temperature.
- A solution of α -acetobromocellobiose in anhydrous dichloromethane is added dropwise to the stirred suspension. The flask is protected from light.
- The reaction mixture is stirred at room temperature for 24-48 hours, with monitoring by TLC.

- After the reaction is complete, the mixture is filtered through Celite, and the solid residue is washed with dichloromethane.
- The combined organic filtrate is washed sequentially with saturated aqueous sodium bicarbonate solution and brine.
- The organic layer is dried over anhydrous sodium sulfate, filtered, and concentrated in vacuo.
- The crude product is purified by silica gel column chromatography to yield the desired cellobioside derivative.

Mandatory Visualization

The following diagrams illustrate the general reaction mechanism and a typical experimental workflow for the Koenigs-Knorr glycosylation.

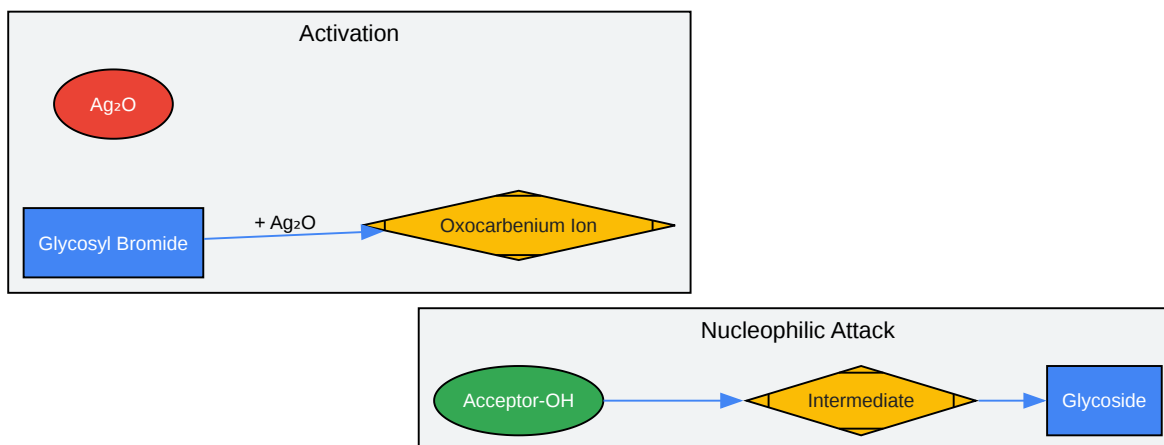

[Click to download full resolution via product page](#)

Caption: General mechanism of the Koenigs-Knorr reaction.

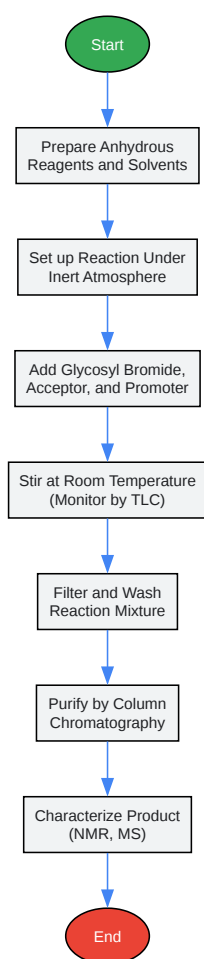

[Click to download full resolution via product page](#)

Caption: Experimental workflow for a Koenigs-Knorr glycosylation.

Conclusion

In summary, both α -acetobromoglucose and α -**acetobromocellobiose** are highly valuable glycosyl donors. The primary factor differentiating their reactivity is the increased steric hindrance of the disaccharide, which generally leads to slower reaction rates for **acetobromocellobiose**. Consequently, glycosylation reactions with **acetobromocellobiose** may require longer reaction times or slightly adjusted conditions to achieve optimal yields. The choice of donor will ultimately be guided by the specific requirements of the synthetic target, with the understanding that the reactivity of the disaccharide donor needs to be carefully considered during experimental design.

- To cite this document: BenchChem. [A Comparative Guide to the Reactivity of Acetobromocellobiose and Acetobromoglucose in Glycosylation Reactions]. BenchChem, [2025]. [Online PDF]. Available at: [https://www.benchchem.com/product/b079220#comparative-reactivity-of-acetobromocellobiose-and-acetobromoglucose]

Disclaimer & Data Validity:

The information provided in this document is for Research Use Only (RUO) and is strictly not intended for diagnostic or therapeutic procedures. While BenchChem strives to provide accurate protocols, we make no warranties, express or implied, regarding the fitness of this product for every specific experimental setup.

Technical Support: The protocols provided are for reference purposes. Unsure if this reagent suits your experiment? [[Contact our Ph.D. Support Team for a compatibility check](#)]

Need Industrial/Bulk Grade? [Request Custom Synthesis Quote](#)

BenchChem

Our mission is to be the trusted global source of essential and advanced chemicals, empowering scientists and researchers to drive progress in science and industry.

Contact

Address: 3281 E Guasti Rd

Ontario, CA 91761, United States

Phone: (601) 213-4426

Email: info@benchchem.com