

# Engineering High-Affinity Peptide Therapeutics via Halogen Bonding

**Author:** BenchChem Technical Support Team. **Date:** April 2026

## Compound of Interest

Compound Name: *3,5-Dichloro-n-boc-DL-phenylalanine*

Cat. No.: *B7893388*

[Get Quote](#)

## A Strategic Application Guide for Drug Development Abstract

This guide outlines the strategic application of Halogen Bonding (XB) to optimize peptide-protein interactions (PPIs). While often overshadowed by hydrogen bonding, XB offers a unique, highly directional interaction (

-hole) capable of enhancing binding affinity, selectivity, and proteolytic stability. This document provides a theoretical framework, specific design strategies, and detailed protocols for synthesizing and characterizing halogenated peptides using 4-iodo-phenylalanine as a model system.

### Introduction: The Sigma-Hole Concept

Halogen bonding is not merely a hydrophobic effect; it is a specific, electrostatic interaction. Unlike a uniform electron cloud, heavier halogens (Cl, Br, I) bound to electron-withdrawing groups exhibit an anisotropic charge distribution.

- The Sigma-Hole (

-hole): A region of positive electrostatic potential located on the extension of the C–X bond axis.<sup>[1]</sup>

- The Interaction: This positive "cap" interacts attractively with Lewis bases (nucleophiles) such as backbone carbonyl oxygens, histidine nitrogens, or carboxylates.
- Directionality: The interaction is strictly linear ( ), offering geometric specificity that hydrophobic interactions lack.

Comparison of Interaction Energies:

- Fluorine (F): No -hole (too electronegative). Acts as an H-bond acceptor or isostere for H.
- Chlorine (Cl): Weak -hole.
- Bromine (Br): Moderate strength.
- Iodine (I): Strongest -hole; strongest XB donor (can rival H-bonds, kcal/mol).

## Visualization: The Mechanism of Halogen Bonding

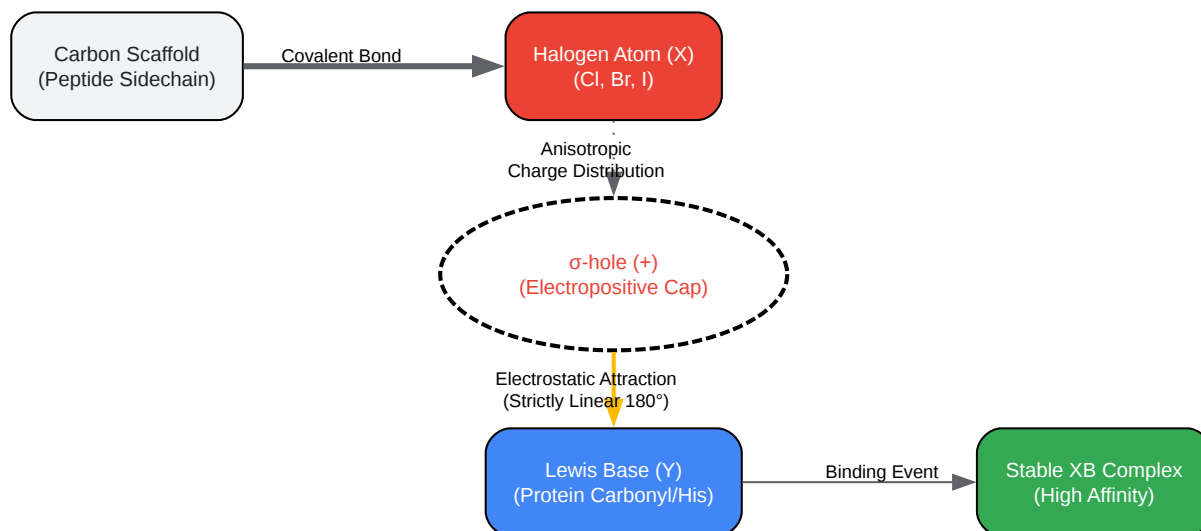

[Click to download full resolution via product page](#)

Figure 1: The anatomy of a Halogen Bond. The positive

-hole on the halogen interacts linearly with the electron-rich Lewis base on the target protein.

## Strategic Design: Incorporating XB into Peptides

To leverage XB, one cannot simply "sprinkle" halogens. The design must be geometric and electronic.

Feature	Design Recommendation
Target Residue	Replace Phenylalanine (Phe) or Tyrosine (Tyr) with halogenated analogs.
Analog Choice	4-iodo-phenylalanine (4-I-Phe) is the gold standard for maximizing affinity due to the large, polarizable Iodine atom.
Binding Pocket	Target pockets with a backbone carbonyl or buried water located from the aromatic ring tip.
Geometry	The C–X bond must point directly at the electron donor. If the angle is $< 90^\circ$ , the interaction repulsive (due to the halogen's equatorial electron belt).

## Protocol 1: Solid-Phase Peptide Synthesis (SPPS) of Halogenated Peptides

Objective: Synthesize a peptide containing the non-canonical amino acid Fmoc-4-iodo-L-phenylalanine (Fmoc-Phe(4-I)-OH) without dehalogenation.

Materials:

- Resin: Rink Amide MBHA (0.5 mmol/g loading).
- Amino Acid: Fmoc-Phe(4-I)-OH (commercial or synthesized).
- Coupling Reagents: HBTU / DIPEA (Standard) or DIC / Oxyma (for lower racemization risk).
- Solvents: DMF (peptide grade), DCM.<sup>[2][3]</sup>
- Precaution: Iodine-carbon bonds can be light-sensitive. Wrap reaction vessels in aluminum foil.

### Step-by-Step Procedure:

- Resin Swelling:
  - Weigh 0.1 mmol resin into a fritted syringe.
  - Swell in DCM (30 min) followed by DMF (30 min).
- Fmoc Deprotection:
  - Treat with 20% Piperidine in DMF (min).<sup>[4]</sup>
  - Note: Do not extend deprotection times unnecessarily to avoid potential side reactions with the halogenated ring (though rare with Iodine).
  - Wash: DMF (min).
- Coupling of Fmoc-Phe(4-I)-OH:
  - Dissolve Fmoc-Phe(4-I)-OH (4 eq), HBTU (3.9 eq) in DMF.
  - Add DIPEA (8 eq) to activate.
  - Immediately add to resin.
  - Rock for 45–60 min at room temperature (protected from light).
  - QC: Perform Kaiser test.<sup>[3][5]</sup> If not blue, coupling is complete.
- Chain Elongation:
  - Proceed with standard Fmoc-SPPS for the remaining sequence.
- Cleavage & Deprotection:

- Cocktail: TFA/TIPS/Water (95:2.5:2.5). Avoid thiols (EDT/DODT) if possible, or use with caution, as radical mechanisms could theoretically reduce the aryl iodide, though standard acidolysis is usually safe.
- Incubate 2 hours.
- Precipitate in cold diethyl ether.
- Purification:
  - HPLC: C18 column.[4] Gradient: Water/Acetonitrile (+0.1% TFA).
  - Observation: The iodinated peptide will elute significantly later (more hydrophobic) than the WT Phe variant.

## Protocol 2: Biophysical Characterization (ITC)

Objective: Confirm the presence of a Halogen Bond via its thermodynamic signature. XB is typically enthalpy-driven (

) due to the electrostatic bond formation, whereas non-specific hydrophobic burial is often entropy-driven.

Experimental Setup:

- Instrument: MicroCal PEAQ-ITC (or equivalent).
- Cell: Protein Target ( ) in buffer (PBS pH 7.4).
- Syringe: Halogenated Peptide ( ) in exact same buffer.

Procedure:

- Degas samples thoroughly (bubbles ruin heat measurements).
- Titration: 19 injections of

each, 150s spacing, 25°C.

- Control: Titrate peptide into buffer (to subtract heat of dilution).

Data Analysis (The Signature): Compare the thermodynamic parameters of the Wild-Type (Phe) vs. Mutant (4-I-Phe).

Parameter	Wild-Type (Phe)	XB Analog (4-I-Phe)	Interpretation
(Affinity)			10-fold improvement indicates strong interaction.
(Enthalpy)			Key Indicator: Significant gain in enthalpy confirms specific bond formation (XB).
(Entropy)			Entropy penalty (rigidification) is overcome by the strong enthalpic gain.

## Workflow: Optimization Cycle

This diagram illustrates the iterative process of optimizing a peptide lead using Halogen Scanning.

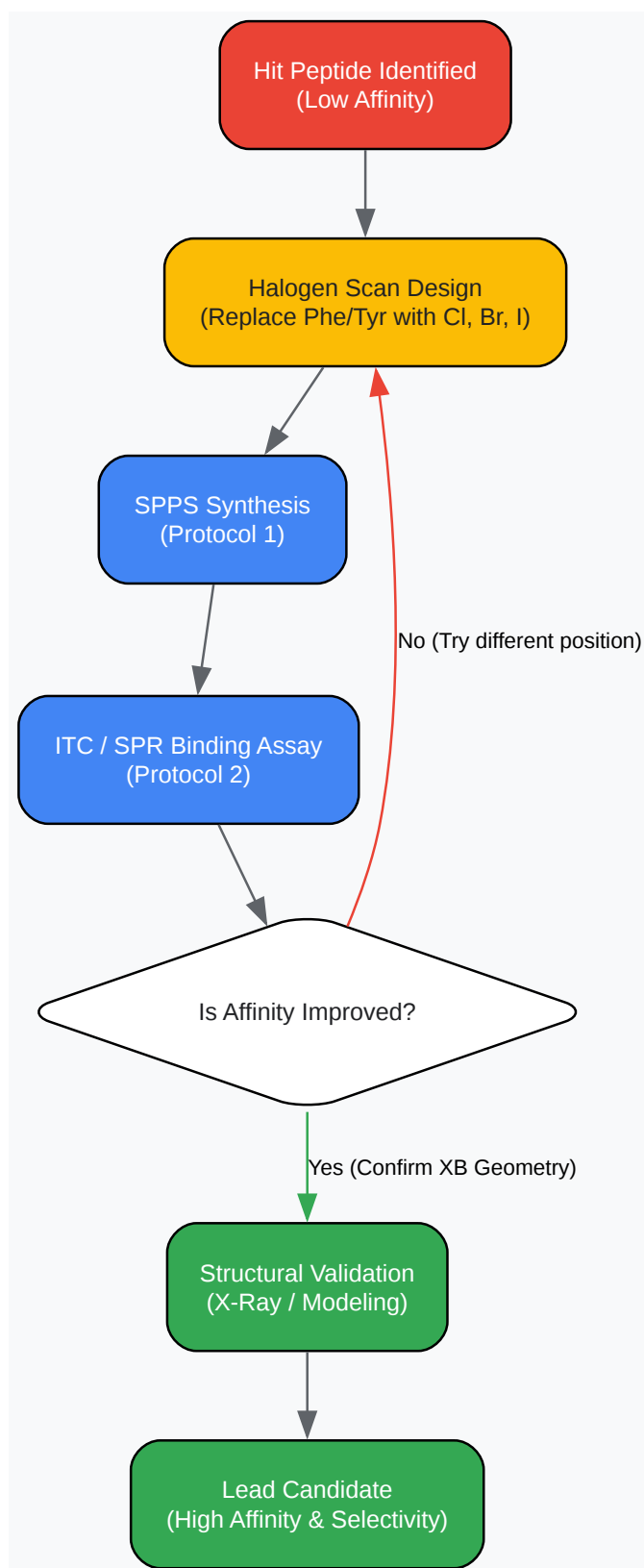

[Click to download full resolution via product page](#)

Figure 2: Iterative workflow for "Halogen Scanning" to optimize peptide affinity.

## References

- Scholfield, M. R., et al. (2013). "Halogen bonding in biological molecules." *Protein Science*. [Link](#)
- Wilcken, R., et al. (2013). "Halogen bonding in drug discovery: overview and recent developments." *Journal of Medicinal Chemistry*. [Link](#)
- Hardegger, L. A., et al. (2011). "Systematic investigation of halogen bonding in protein–ligand interactions." *Angewandte Chemie International Edition*. [Link](#)
- Parisini, E., et al. (2011). "Halogen bonding in peptide–protein interactions." *ChemMedChem*. [Link](#)
- BenchChem Application Note. "The Use of Fmoc-Phe(4-Br)-OH in Protein Engineering." [Link](#)

### *Need Custom Synthesis?*

*BenchChem offers custom synthesis for rare earth carbides and specific isotopic labeling.*

*Email: [info@benchchem.com](mailto:info@benchchem.com) or [Request Quote Online](#).*

## Sources

- [1. Modulation of the Interaction between a Peptide Ligand and a G Protein-Coupled Receptor by Halogen Atoms - PMC \[pmc.ncbi.nlm.nih.gov\]](#)
- [2. chemistry.du.ac.in \[chemistry.du.ac.in\]](#)
- [3. pdf.benchchem.com \[pdf.benchchem.com\]](#)
- [4. pdf.benchchem.com \[pdf.benchchem.com\]](#)
- [5. peptide.com \[peptide.com\]](#)
- To cite this document: BenchChem. [Engineering High-Affinity Peptide Therapeutics via Halogen Bonding]. BenchChem, [2026]. [Online PDF]. Available at: [\[https://www.benchchem.com/product/b7893388/docs#engineering-high-affinity-peptide-therapeutics-via-halogen-bonding\]](https://www.benchchem.com/product/b7893388/docs#engineering-high-affinity-peptide-therapeutics-via-halogen-bonding)

---

### Disclaimer & Data Validity:

The information provided in this document is for Research Use Only (RUO) and is strictly not intended for diagnostic or therapeutic procedures. While BenchChem strives to provide accurate protocols, we make no warranties, express or implied, regarding the fitness of this product for every specific experimental setup.

**Technical Support:** The protocols provided are for reference purposes. Unsure if this reagent suits your experiment?

**Need Industrial/Bulk Grade?** [Request Custom Synthesis Quote](#)

## BenchChem

Our mission is to be the trusted global source of essential and advanced chemicals, empowering scientists and researchers to drive progress in science and industry.

### Contact

Address: 3281 E Guasti Rd  
Ontario, CA 91761, United States  
Phone: (601) 213-4426  
Email: [info@benchchem.com](mailto:info@benchchem.com)

[Contact our Ph.D. Support Team for a compatibility check](#)