

3-Chloro-2-(cyclohexyloxy)pyridine chemical properties

Author: BenchChem Technical Support Team. **Date:** May 2026

Compound of Interest

Compound Name: 3-Chloro-2-(cyclohexyloxy)pyridine

Cat. No.: B7892660

[Get Quote](#)

Technical Guide: 3-Chloro-2-(cyclohexyloxy)pyridine

Part 1: Executive Summary & Chemical Identity

3-Chloro-2-(cyclohexyloxy)pyridine is a lipophilic pyridine ether scaffold used primarily as a building block in medicinal chemistry. It serves as a critical intermediate for introducing the 2-alkoxy-3-chloropyridine motif, a bioisostere often employed to modulate metabolic stability and lipophilicity in drug candidates targeting GPCRs (e.g., mGluR modulators) and ion channels (e.g., P2X3 antagonists).

Chemical Profile

Property	Data
IUPAC Name	3-Chloro-2-(cyclohexyloxy)pyridine
CAS Number	Not widely listed for parent; see 2096330-07-1 for 4-boronic acid derivative
Molecular Formula	C ₁₁ H ₁₄ ClNO
Molecular Weight	211.69 g/mol
Predicted LogP	~3.8 (Highly Lipophilic)
H-Bond Acceptors	2 (N, O)
H-Bond Donors	0
Physical State	Colorless to pale yellow oil (typically)

Part 2: Physicochemical Properties & Engineering

This molecule combines the electron-deficient nature of the pyridine ring with the steric bulk and lipophilicity of the cyclohexyl group.

Electronic & Steric Environment[1]

- **Pyridine Nitrogen:** The nitrogen atom exerts a strong electron-withdrawing effect, activating the C2 and C4 positions. In this molecule, the C2 position is capped by the cyclohexyloxy group.
- **3-Chloro Substituent:** Provides a handle for further functionalization (e.g., Suzuki-Miyaura coupling) but also sterically influences the conformation of the adjacent ether linkage, often forcing the cyclohexyl group out of plane.
- **Cyclohexyl Ether:** Significantly increases lipophilicity (cLogP ~3.8) compared to methoxy or ethoxy analogs. This can improve blood-brain barrier (BBB) penetration but may increase non-specific binding.

Solubility Profile

- **Water:** Insoluble.

- Organic Solvents: Highly soluble in DCM, EtOAc, THF, and DMSO.
- Acid Stability: The ether linkage is generally stable to weak acids but can undergo cleavage (de-alkylation) under strong acidic conditions (e.g., HBr/AcOH) to yield 3-chloro-2-pyridone.

Part 3: Synthetic Methodologies

The synthesis relies on Nucleophilic Aromatic Substitution (S_NAr).^{[1][2][3]} The reaction is highly regioselective due to the electronic activation of the C2 position by the adjacent pyridine nitrogen.

Protocol: Regioselective S_NAr Synthesis

Reaction: 2,3-Dichloropyridine + Cyclohexanol

3-Chloro-2-(cyclohexyloxy)pyridine

Reagents:

- Substrate: 2,3-Dichloropyridine (1.0 eq)^{[2][3]}
- Nucleophile: Cyclohexanol (1.2 eq)
- Base: Sodium Hydride (NaH, 60% in oil, 1.5 eq) or Potassium tert-butoxide (tBuOK)
- Solvent: Anhydrous THF or DMF
- Conditions: 0°C to Room Temperature (or mild heat 60°C if sluggish)

Step-by-Step Workflow:

- Activation: Suspend NaH (1.5 eq) in anhydrous THF under N_2 atmosphere at 0°C.
- Alkoxide Formation: Dropwise add cyclohexanol (1.2 eq). Stir for 30 min until H_2 evolution ceases. Critical: Ensure complete deprotonation to maximize nucleophilicity.
- Addition: Add 2,3-dichloropyridine (1.0 eq) dissolved in THF dropwise to the alkoxide solution.

- Reaction: Allow to warm to room temperature. Monitor by TLC/LCMS.
 - Mechanistic Insight: The nucleophile attacks C2 preferentially over C3 because the transition state (Meisenheimer complex) at C2 is stabilized by the electronegative nitrogen atom.[2][3]
- Workup: Quench with saturated NH_4Cl . Extract with EtOAc. Wash organics with brine, dry over Na_2SO_4 , and concentrate.
- Purification: Silica gel chromatography (Hexanes/EtOAc gradient).

Diagram 1: Synthesis & Regioselectivity Logic

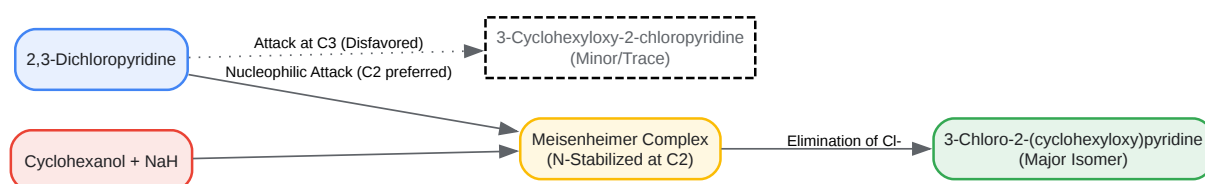

[Click to download full resolution via product page](#)

Caption: Regioselective $\text{S}_{\text{N}}\text{Ar}$ pathway favoring C2 substitution due to nitrogen stabilization of the intermediate.

Part 4: Reactivity & Functionalization

Once synthesized, the 3-chloro group becomes the primary handle for diversification, typically via Palladium-catalyzed cross-coupling.

Suzuki-Miyaura Coupling

The 3-chloro position is sterically hindered by the bulky cyclohexyloxy group at C2.

- Challenge: Oxidative addition of $\text{Pd}(0)$ into the C3-Cl bond is slower than for unhindered chloropyridines.

- Solution: Use electron-rich, bulky phosphine ligands (e.g., XPhos, SPhos, or RuPhos) or NHC ligands to facilitate the coupling.
- Protocol: Pd(OAc)₂ / SPhos, K₃PO₄, Toluene/Water (100°C).

Acid-Mediated Cleavage (Deprotection)

The cyclohexyl group can be removed to reveal the 2-hydroxypyridine (tautomer of 2-pyridone).

- Reagents: TFA (neat) or HBr/AcOH.
- Utility: This converts the lipophilic ether into a polar hydrogen-bond donor/acceptor motif.

Diagram 2: Divergent Functionalization

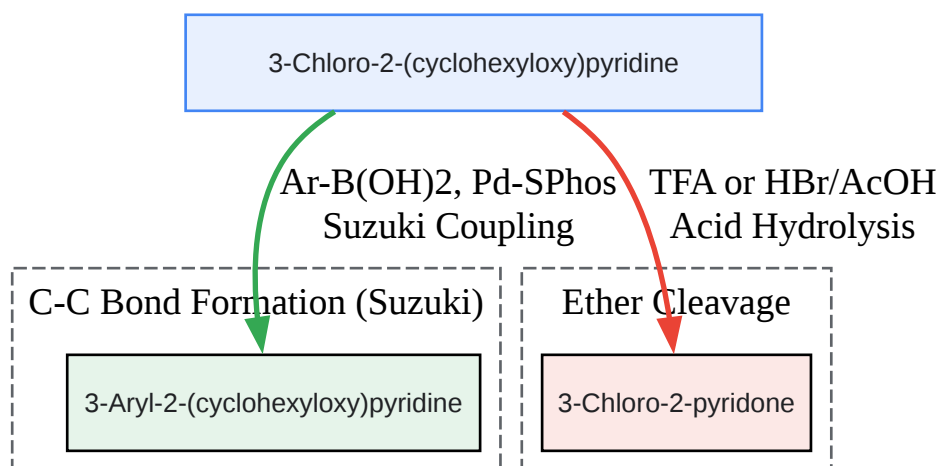

[Click to download full resolution via product page](#)

Caption: Divergent reactivity pathways: Cross-coupling at C3 vs. Ether cleavage at C2.

Part 5: Safety & Handling (SDS Summary)

- Hazards: Like most halopyridines, treat as Irritant (Skin/Eye/Respiratory).
- Acute Toxicity: Potential for acute toxicity if swallowed (Category 4).[4]
- Handling: Use a fume hood.[4][5] Wear nitrile gloves and safety glasses.

- Storage: Store in a cool, dry place. Stable under normal conditions, but avoid strong oxidizing agents.

References

- BenchChem. An In-depth Technical Guide to the Core Reactions of 2,3-Dichloropyridine. [2][3] (2025). [1][2][3][6][7]
- Fisher Scientific. Safety Data Sheet: 3-Chloropyridine. (2025). [1][2][3][6][7]
- WuXi AppTec. Regioselectivity in S_NAr reaction of Dichloropyrimidines (Analogous Chemistry). QM Magic Class, Chapter 29. [8]
- Chem960. CAS 2096330-07-1 Entry (Boronic Acid Derivative).

Need Custom Synthesis?

BenchChem offers custom synthesis for rare earth carbides and specific isotopic labeling.

Email: info@benchchem.com or [Request Quote Online](#).

Sources

- 1. pdf.benchchem.com [pdf.benchchem.com]
- 2. pdf.benchchem.com [pdf.benchchem.com]
- 3. pdf.benchchem.com [pdf.benchchem.com]
- 4. static.cymitquimica.com [static.cymitquimica.com]
- 5. people.chem.umass.edu [people.chem.umass.edu]
- 6. researchgate.net [researchgate.net]
- 7. researchgate.net [researchgate.net]
- 8. Understanding the highly variable Regioselectivity in S_NAr reaction of Dichloropyrimidines - RCS Research Chemistry Services [rcs.wuxiapptec.com]
- To cite this document: BenchChem. [3-Chloro-2-(cyclohexyloxy)pyridine chemical properties]. BenchChem, [2026]. [Online PDF]. Available at:

[\[https://www.benchchem.com/product/b7892660/docs#3-chloro-2-cyclohexyloxy-pyridine-chemical-properties\]](https://www.benchchem.com/product/b7892660/docs#3-chloro-2-cyclohexyloxy-pyridine-chemical-properties)

Disclaimer & Data Validity:

The information provided in this document is for Research Use Only (RUO) and is strictly not intended for diagnostic or therapeutic procedures. While BenchChem strives to provide accurate protocols, we make no warranties, express or implied, regarding the fitness of this product for every specific experimental setup.

Technical Support: The protocols provided are for reference purposes. Unsure if this reagent suits your experiment?

Need Industrial/Bulk Grade? [Request Custom Synthesis Quote](#)

BenchChem

Our mission is to be the trusted global source of essential and advanced chemicals, empowering scientists and researchers to drive progress in science and industry.

Contact

Address: 3281 E Guasti Rd
Ontario, CA 91761, United States
Phone: (601) 213-4426
Email: info@benchchem.com

[Contact our Ph.D. Support Team for a compatibility check](#)