

A Comparative Guide to the Analytical Characterization of Boc-L-4-Bromophenylalaninol

Author: BenchChem Technical Support Team. **Date:** April 2026

Compound of Interest

Compound Name: *Boc-L-4-Bromophenylalaninol*

Cat. No.: *B7889956*

[Get Quote](#)

In the landscape of pharmaceutical development and complex organic synthesis, the unambiguous characterization of novel chemical entities is paramount. Intermediates such as **Boc-L-4-Bromophenylalaninol**, a protected amino alcohol, serve as critical building blocks. Its structural integrity directly impacts the yield, purity, and safety profile of the final active pharmaceutical ingredient (API). This guide provides an in-depth comparison of analytical methodologies for the characterization of this compound, with a primary focus on predicting and interpreting its mass spectrometry fragmentation pattern. We will explore the "why" behind the analytical choices, offering a framework for researchers to develop robust, self-validating characterization protocols.

The Central Role of Mass Spectrometry in Structural Elucidation

Mass spectrometry (MS) is an indispensable tool for organic chemists, providing rapid and highly sensitive molecular weight determination.^[1] When coupled with tandem mass spectrometry (MS/MS), it offers a detailed roadmap of a molecule's structure through controlled fragmentation. For a molecule like **Boc-L-4-Bromophenylalaninol**, Electrospray Ionization

(ESI) is the preferred soft ionization technique, as it typically generates protonated molecular ions $[M+H]^+$ with minimal in-source fragmentation, preserving the crucial molecular weight information.^[2]

Predicting the ESI-MS/MS Fragmentation Cascade

The fragmentation of a molecule in a collision-induced dissociation (CID) experiment is not random; it follows predictable pathways governed by the principles of carbocation stability and the formation of stable neutral losses. For **Boc-L-4-Bromophenylalaninol** (Molecular Weight: 330.23 g/mol), we can anticipate a fragmentation pattern dominated by the lability of the tert-butoxycarbonyl (Boc) protecting group.^{[3][4]}

Key Predicted Fragmentation Pathways:

- **Loss of the Boc Group:** The most characteristic fragmentation of Boc-protected amines involves the loss of isobutylene (56 Da) or the entire Boc group (100 Da).^{[3][5]} Under ESI-CID conditions, the primary pathway is often the loss of isobutylene (C₄H₈, 56 Da) via a McLafferty-type rearrangement, followed by the loss of carbon dioxide (CO₂, 44 Da).^{[3][6]} This two-step loss results in the deprotected, protonated amino alcohol.
- **Cleavage of the Phenylalaninol Backbone:** Following the removal of the Boc group, further fragmentation will occur along the amino alcohol backbone. Alpha-cleavage, the breaking of the C-C bond adjacent to the nitrogen, is a common pathway for amines and alcohols as it leads to the formation of a resonance-stabilized cation.^{[7][8][9]}
- **Influence of the Bromine Atom:** The presence of a bromine atom is a distinct isotopic signature. Bromine has two major isotopes, ⁷⁹Br and ⁸¹Br, in an approximate 1:1 ratio.^[10] ^[11] Therefore, any fragment containing the bromine atom will appear as a pair of peaks (an M and M+2 peak) of nearly equal intensity, which is a powerful diagnostic tool.^[10] Fragmentation can also involve the loss of the bromine radical ([•]Br), although this is more common in electron ionization (EI) than ESI.^[10]

The following diagram illustrates the predicted fragmentation cascade for the protonated molecule.

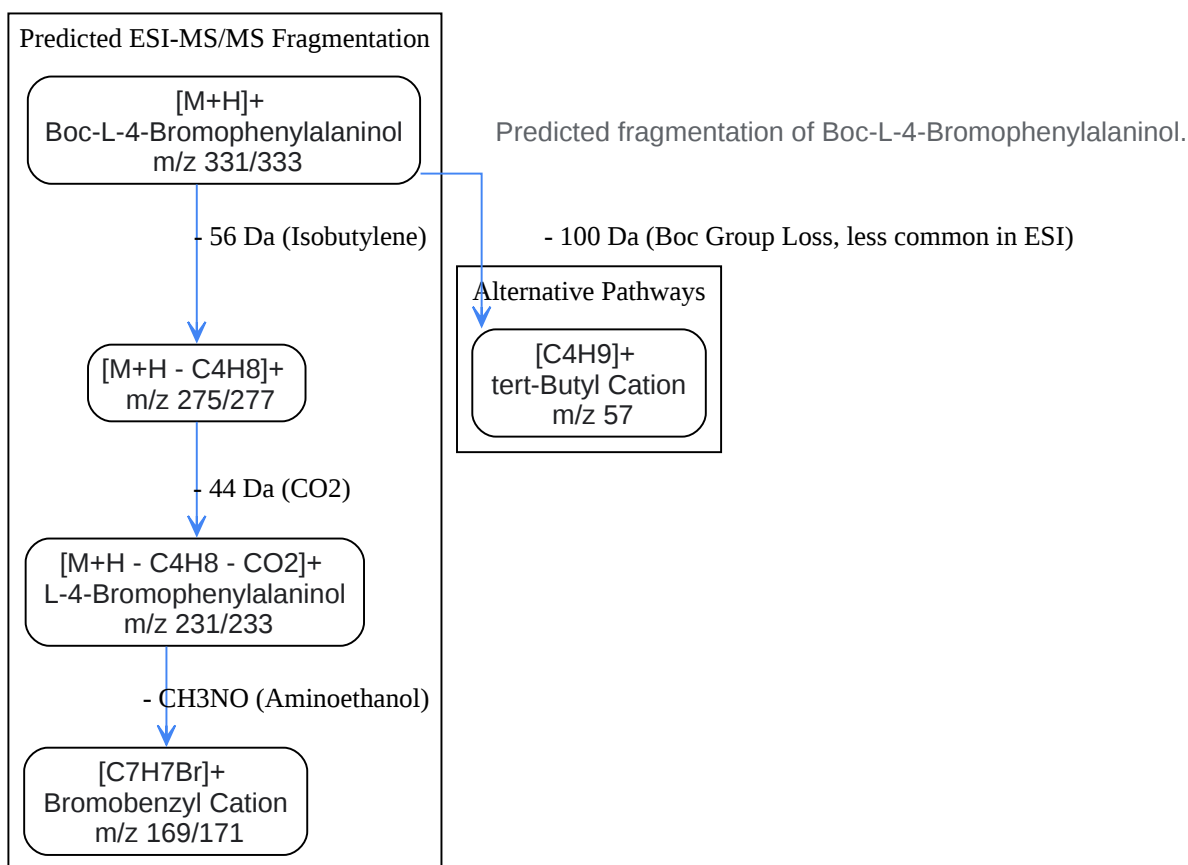

[Click to download full resolution via product page](#)

Caption: Predicted fragmentation of **Boc-L-4-Bromophenylalaninol**.

Experimental Protocol: LC-MS/MS Analysis

A self-validating protocol ensures data integrity. This involves system suitability checks before analysis and the use of orthogonal techniques for confirmation.

- Sample Preparation: Dissolve ~1 mg of **Boc-L-4-Bromophenylalaninol** in 1 mL of a suitable solvent (e.g., methanol or acetonitrile). Dilute this stock solution to a final concentration of 1-

10 µg/mL in the initial mobile phase.

- Chromatographic Separation (LC):
 - Column: A C18 reversed-phase column (e.g., 2.1 x 50 mm, 1.8 µm) is suitable for retaining this moderately polar analyte.[12]
 - Mobile Phase A: Water + 0.1% Formic Acid.
 - Mobile Phase B: Acetonitrile + 0.1% Formic Acid. (Note: Avoid Trifluoroacetic Acid (TFA), as it can cause in-source deprotection of the Boc group.[13])
 - Gradient: Start with a low percentage of B (e.g., 5-10%), ramp up to 95% B to elute the compound, and then re-equilibrate.
- Mass Spectrometry (MS):
 - Ionization Mode: Positive Electrospray Ionization (ESI+).
 - MS1 Scan: Scan a mass range that includes the expected protonated molecule (e.g., m/z 100-500) to confirm the [M+H]⁺ ion at m/z 331/333.
 - MS2 (Tandem MS) Scan: Select the precursor ion (m/z 331) for collision-induced dissociation (CID). Ramp the collision energy (e.g., 10-40 eV) to generate a comprehensive fragmentation spectrum.

Comparison with Alternative Analytical Methods

While MS/MS is powerful for structural elucidation, it should not be used in isolation.

Orthogonal techniques provide complementary information, leading to a more confident and complete characterization.

Analytical Technique	Information Provided	Sensitivity	Throughput	Key Strengths & Weaknesses
LC-MS/MS	Molecular Weight, Fragmentation Pattern (Connectivity), Isotopic Information.[12] [14]	Very High (pg-ng)	High	Strengths: Excellent for identifying knowns/unknowns, requires minimal sample. Weaknesses: Isomer differentiation can be challenging, labile groups may fragment in-source.[13]
NMR Spectroscopy (¹ H, ¹³ C)	Definitive atom connectivity, stereochemistry, and 3D structure. [15]	Low (mg)	Low	Strengths: Gold standard for unambiguous structure confirmation. Weaknesses: Requires significantly more sample, less sensitive, complex mixtures are difficult to analyze.
FT-IR Spectroscopy	Presence of key functional groups (e.g., C=O, N-H, O-H).[16]	Moderate (µg-mg)	High	Strengths: Fast, non-destructive, confirms functional groups. Weaknesses:

Provides no information on molecular weight or connectivity.

Nuclear Magnetic Resonance (NMR) Spectroscopy

NMR is the gold standard for determining the precise chemical structure of an organic molecule.

- ^1H NMR: Would confirm the presence of the tert-butyl protons (a singlet around 1.4 ppm), the aromatic protons on the bromophenyl ring (a characteristic AA'BB' pattern), and the diastereotopic protons of the ethylamino alcohol backbone.[15]
- ^{13}C NMR: Would show distinct signals for the carbonyl of the Boc group (~155 ppm), the carbons of the tert-butyl group, and the aromatic carbons, including the carbon attached to the bromine atom.

NMR provides the definitive connectivity that MS can only infer from fragmentation. For example, MS cannot easily distinguish between **Boc-L-4-Bromophenylalaninol** and an isomeric structure like Boc-L-2-Bromophenylalaninol. NMR, however, would show a completely different aromatic splitting pattern, making the distinction trivial.

Fourier-Transform Infrared (FT-IR) Spectroscopy

FT-IR is a rapid and simple technique to confirm the presence of expected functional groups. For **Boc-L-4-Bromophenylalaninol**, the key absorbances would be:

- $\sim 3400\text{ cm}^{-1}$: O-H stretch from the alcohol.
- $\sim 3300\text{ cm}^{-1}$: N-H stretch from the carbamate.
- $\sim 1690\text{ cm}^{-1}$: C=O stretch from the Boc group's carbonyl.[16]
- ~ 1390 and $\sim 1365\text{ cm}^{-1}$: A characteristic doublet indicating the presence of a tert-butyl group.
[17]

The disappearance of the primary amine bands and the appearance of the strong carbonyl and N-H bands of the carbamate would confirm the successful Boc protection of the parent amino alcohol.^[16]

Integrated Analytical Workflow

For robust characterization in a drug development setting, an integrated approach is essential. The following workflow ensures both efficiency and scientific rigor.

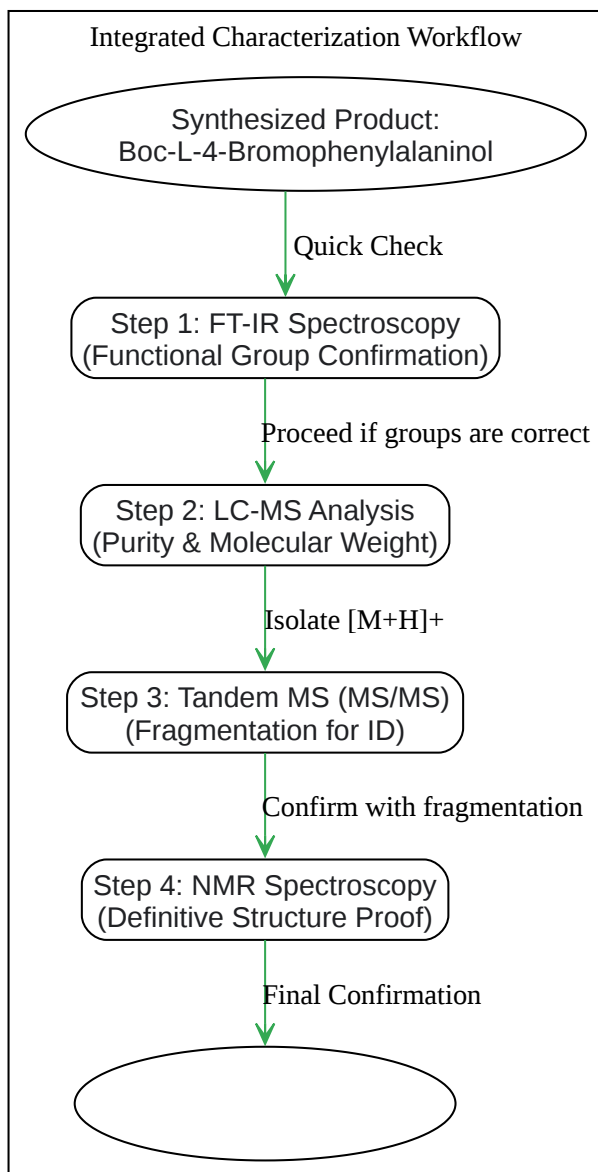

Workflow for compound characterization.

[Click to download full resolution via product page](#)

Caption: Workflow for compound characterization.

Conclusion

The characterization of **Boc-L-4-Bromophenylalaninol** serves as an excellent model for the multi-faceted analytical approach required in modern chemical research. While mass spectrometry provides unparalleled sensitivity and crucial structural clues through its predictable fragmentation patterns—dominated by the facile loss of the Boc group—it is not an island.^{[3][18]} True analytical trustworthiness is achieved by integrating MS data with the definitive connectivity information from NMR and the functional group confirmation from FT-IR. This holistic, self-validating workflow ensures that researchers and drug developers can proceed with confidence in the identity and purity of their materials, a cornerstone of scientific integrity.

References

- Srinivasu, B., Raju, B., Sridhar, B., & Rao, R. N. (2010). Differentiation of Boc-protected alpha,delta-/delta,alpha- and beta,delta-/delta,beta-hybrid peptide positional isomers by electrospray ionization tandem mass spectrometry. *Journal of Mass Spectrometry*, 45(9), 1039–1048. Available at: [\[Link\]](#)
- Liu, C., et al. (2025). Mass Fragmentation Characteristics of t-Boc Substituted Drug Precursors. *Journal of Chinese Mass Spectrometry Society*, 46(1), 40-47. Available at: [\[Link\]](#)
- Moser, A. (2008). Confirmation of Synthesis: using MS to identify a protective group. *ACD/Labs*. Available at: [\[Link\]](#)
- Dan-Hui, Y., & Wen-Jie, M. (2005). Elucidation of the Presence and Location of t-Boc Protecting Groups in Amines and Dipeptides Using On-Column H/D Exchange HPLC/ESI/MS. *Journal of the American Society for Mass Spectrometry*, 16(4), 553-564. Available at: [\[Link\]](#)
- Naskar, D., & Roy, S. (2000). Efficient and selective cleavage of the tert-butoxycarbonyl (Boc) group under basic condition. *Tetrahedron*, 56(10), 1369-1377. Available at: [\[Link\]](#)
- Goud, P. M., et al. (2012). Solvent-free, instant, ambient, n-boc protection of amines -A green, recyclable heterogenous acid catalysis. *Der Pharma Chemica*, 4(5), 1878-1883. Available at: [\[Link\]](#)

- Isidro-Llobet, A., et al. (2015). TFA Cleavage Strategy for Mitigation of S-tButylated Cys-Peptide Formation in Solid-Phase Peptide Synthesis. *Organic Process Research & Development*, 19(3), 444-451. Available at: [\[Link\]](#)
- Moroder, L., et al. (1986). Selective Acidic Cleavage of the tert-Butoxycarbonyl Group. *Helvetica Chimica Acta*, 69(3), 707-716. Available at: [\[Link\]](#)
- Anson, A., et al. (2007). FTIR spectra for the Boc-aminated and unprotected SWCNT. ResearchGate. Available at: [\[Link\]](#)
- Bugatti, K. (2021). How can I avoid the Boc-cleavage during Mass Analysis? ResearchGate. Available at: [\[Link\]](#)
- Wikipedia. (n.d.). tert-Butyloxycarbonyl protecting group. Available at: [\[Link\]](#)
- eGyanKosh. (n.d.). MASS SPECTROMETRY: FRAGMENTATION PATTERNS. Available at: [\[Link\]](#)
- Kumar, S., et al. (2013). N-tert-Butoxycarbonylation of Structurally Diverse Amines and Sulfamides under Water-Mediated Catalyst-Free Conditions. *International Journal of Organic Chemistry*, 3(1), 1-5. Available at: [\[Link\]](#)
- Tamilnadu Test House. (2025). Analytical Methods For Amino Acids. Available at: [\[Link\]](#)
- Reddit. (2023). I knew about the MS fragmentation pattern with Boc protected amines, but didn't realize until recently that the M-56 peak might be due to a McLafferty-like fragmentation. *r/OrganicChemistry*. Available at: [\[Link\]](#)
- Wang, M., et al. (2020). Analytical methods for amino acid determination in organisms. *Journal of Chromatography B*, 1150, 122187. Available at: [\[Link\]](#)
- Arshad, N., et al. (2012). Scheme. Mass fragmentation pattern of N-{ [(4-bromophenyl)amino] carbonothioyl} benzamide. ResearchGate. Available at: [\[Link\]](#)
- Li, S., et al. (2012). FT-IR spectra of 3-amino-1-propanol (a) and tert-butylN-(3-hydroxypropyl) carbamate (b). ResearchGate. Available at: [\[Link\]](#)

- Scribd. (n.d.). Halogen Fragmentation in Mass Spectrometry. Available at: [\[Link\]](#)
- LibreTexts. (2023). Mass Spectrometry - Fragmentation Patterns. Available at: [\[Link\]](#)
- Shimadzu. (n.d.). Analytical Methods for Amino Acids. Available at: [\[Link\]](#)
- Kertesz, V. (2019). An Organic Chemist's Guide to Electrospray Mass Spectrometric Structure Elucidation. *Molecules*, 24(3), 587. Available at: [\[Link\]](#)
- US Pharmacopeia (USP). (n.d.). Amino acid analysis. Available at: [\[Link\]](#)
- Michigan State University. (n.d.). Mass Spectrometry. Available at: [\[Link\]](#)
- Chad's Prep. (2018). 14.6b Fragmentation Patterns of Alkyl Halides, Alcohols, and Amines | Mass Spectrometry. Available at: [\[Link\]](#)
- Vessecchi, R., et al. (2016). Fragmentation reactions using electrospray ionization mass spectrometry: an important tool for the structural elucidation and characterization of synthetic and natural products. *Natural Product Reports*, 33(2), 227-255. Available at: [\[Link\]](#)
- University of Arizona. (n.d.). Mass Spectrometry: Fragmentation. Available at: [\[Link\]](#)
- Organic Chemistry Portal. (n.d.). Boc-Protected Amino Groups. Available at: [\[Link\]](#)
- Organic Syntheses. (n.d.). N-tert-BUTOXYCARBONYL-L-PHENYLALANINE. Available at: [\[Link\]](#)
- Hesse, M., Meier, H., & Zeeh, B. (2008). *Spectroscopic Methods in Organic Chemistry*. Thieme. Available at: [\[Link\]](#)
- Royal Society of Chemistry. (2011). Supporting Information. Available at: [\[Link\]](#)

Need Custom Synthesis?

BenchChem offers custom synthesis for rare earth carbides and specific isotopic labeling.

Email: info@benchchem.com or [Request Quote Online](#).

Sources

- 1. acdlabs.com [acdlabs.com]
- 2. An Organic Chemist's Guide to Electrospray Mass Spectrometric Structure Elucidation - PMC [[pmc.ncbi.nlm.nih.gov](https://pubmed.ncbi.nlm.nih.gov)]
- 3. Mass Fragmentation Characteristics of *t*-Boc Substituted Drug Precursors [zpxb.xml-journal.net]
- 4. pdf.benchchem.com [pdf.benchchem.com]
- 5. reddit.com [reddit.com]
- 6. fileservers-az.core.ac.uk [fileservers-az.core.ac.uk]
- 7. chem.libretexts.org [chem.libretexts.org]
- 8. youtube.com [youtube.com]
- 9. chemistry.miamioh.edu [chemistry.miamioh.edu]
- 10. scribd.com [scribd.com]
- 11. Mass Spectrometry [www2.chemistry.msu.edu]
- 12. Amino Acid Analysis Methods - Creative Proteomics [creative-proteomics.com]
- 13. researchgate.net [researchgate.net]
- 14. tamilnadutesthouse.com [tamilnadutesthouse.com]
- 15. Organic Syntheses Procedure [orgsyn.org]
- 16. researchgate.net [researchgate.net]
- 17. researchgate.net [researchgate.net]
- 18. Differentiation of Boc-protected alpha,delta-/delta,alpha- and beta,delta-/delta,beta-hybrid peptide positional isomers by electrospray ionization tandem mass spectrometry - PubMed [pubmed.ncbi.nlm.nih.gov]
- To cite this document: BenchChem. [A Comparative Guide to the Analytical Characterization of Boc-L-4-Bromophenylalaninol]. BenchChem, [2026]. [Online PDF]. Available at: [<https://www.benchchem.com/product/b7889956/docs#a-comparative-guide-to-the-analytical-characterization-of-boc-l-4-bromophenylalaninol>]

Disclaimer & Data Validity:

The information provided in this document is for Research Use Only (RUO) and is strictly not intended for diagnostic or therapeutic procedures. While BenchChem strives to provide accurate protocols, we make no warranties, express or implied, regarding the fitness of this product for every specific experimental setup.

Technical Support: The protocols provided are for reference purposes. Unsure if this reagent suits your experiment?

Need Industrial/Bulk Grade? [Request Custom Synthesis Quote](#)

BenchChem

Our mission is to be the trusted global source of essential and advanced chemicals, empowering scientists and researchers to drive progress in science and industry.

Contact

Address: 3281 E Guasti Rd
Ontario, CA 91761, United States
Phone: (601) 213-4426
Email: info@benchchem.com

[Contact our Ph.D. Support Team for a compatibility check](#)