

# Application Note: High-Sensitivity GC-MS Profiling of Dihydroactinidiolide (DHA)

**Author:** BenchChem Technical Support Team. **Date:** May 2026

## Compound of Interest

Compound Name: *Dihydroactinidiolide*

Cat. No.: *B7888491*

[Get Quote](#)

## Executive Summary

This application note details a robust protocol for the extraction, separation, and mass spectral identification of **Dihydroactinidiolide** (DHA). DHA is a volatile terpene lactone (

) resulting from the thermal degradation of

-carotene. It is a critical analyte in three distinct fields:

- **Flavor & Fragrance:** A key aroma compound in tea (*Camellia sinensis*) and tobacco.
- **Chemical Ecology:** A pheromone component for the Red Imported Fire Ant (*Solenopsis invicta*) and a felid attractant in Silver Vine (*Actinidia polygama*).
- **Drug Discovery:** A bioactive scaffold exhibiting acetylcholinesterase (AChE) inhibitory potential (Alzheimer's research) and cytotoxic activity against specific cancer cell lines.<sup>[1]</sup>

This guide prioritizes Headspace-SPME for qualitative profiling and Liquid-Liquid Extraction (LLE) for quantitative analysis in complex matrices.

## Chemical Profile & Target Properties

Understanding the physicochemical properties of DHA is a prerequisite for selecting the correct extraction solvent and GC column stationary phase.

Property	Specification	Analytical Implication
IUPAC Name	4,4,7a-trimethyl-5,6,7,7a-tetrahydro-1-benzofuran-2(4H)-one	Cyclic lactone structure requires mid-polarity considerations.
Molecular Weight	180.24 g/mol	Parent ion ( ) is stable but often low abundance in EI.
Boiling Point	~296 °C (at 760 mmHg)	Requires a GC oven ramp up to at least 280 °C.
LogP	~2.6	Lipophilic; extracts well in non-polar solvents (Hexane, DCM).
Retention Index (RI)	1530–1555 (DB-5ms)	Elutes in the sesquiterpene region.

## Sample Preparation Protocols

### Method A: Headspace-SPME (Qualitative Profiling)

Best for: Aroma profiling in tea, tobacco, or insect pheromone detection.

Rationale: DHA is semi-volatile. Direct immersion SPME is risky due to matrix interferences (waxes/lipids), so Headspace (HS-SPME) is preferred. We utilize a DVB/CAR/PDMS fiber because DHA contains both a non-polar backbone and a polar lactone moiety, requiring a mixed-mode fiber for optimal adsorption.

Protocol:

- Sample: Place 2.0 g of homogenized sample (e.g., tea leaves) into a 20 mL headspace vial.
- Conditioning: Add 5 mL saturated NaCl solution (to salt-out volatiles) and 10 µL Internal Standard (e.g., 2-Acetylthiophene, 50 ppm).

- Incubation: Equilibrate at 60°C for 15 minutes with agitation (250 rpm).
- Extraction: Expose the 50/30 µm DVB/CAR/PDMS fiber to the headspace for 40 minutes at 60°C.
- Desorption: Desorb immediately in the GC inlet at 250°C for 3 minutes (Splitless mode).

## Method B: Liquid-Liquid Extraction (Quantitative)

Best for: Bioactive assays and precise quantification in plant extracts.

Rationale: LLE provides exhaustive extraction. Dichloromethane (DCM) is the solvent of choice due to its high volatility (easy concentration) and excellent solubility for terpene lactones.

Protocol:

- Extraction: Macerate 5 g of plant material in 50 mL Methanol (to penetrate cell walls). Sonicate for 20 mins.
- Partition: Filter extract.<sup>[2]</sup> Add 20 mL water, then partition with 3 x 20 mL Dichloromethane (DCM).
- Drying: Collect the organic (DCM) layer and dry over anhydrous .
- Concentration: Concentrate to 1 mL using a rotary evaporator (low vacuum, 35°C) or nitrogen stream. Do not evaporate to dryness to prevent loss of volatiles.

## Instrumental Method (GC-MS)<sup>[3][4][5]</sup>

### Gas Chromatography Parameters

- System: Agilent 7890B / 5977B MSD (or equivalent).
- Column: DB-5ms UI (30 m × 0.25 mm × 0.25 µm).
  - Note: A "UI" (Ultra Inert) column is critical. Lactones can tail on active sites; an inert column ensures sharp peak shapes.

- Carrier Gas: Helium @ 1.0 mL/min (Constant Flow).
- Inlet: Splitless (for trace analysis) or Split 1:10 (for high abundance). Temp: 250°C.
- Oven Program:
  - Initial: 60°C (Hold 2 min) — Solvent delay/venting.
  - Ramp 1: 5°C/min to 200°C — Crucial slow ramp for separating DHA from co-eluting sesquiterpenes.
  - Ramp 2: 20°C/min to 280°C (Hold 5 min) — Column bake-out.

## Mass Spectrometry Parameters

- Source Temp: 230°C.
- Quad Temp: 150°C.
- Ionization: Electron Impact (EI) at 70 eV.
- Acquisition Mode:
  - SCAN: m/z 40–400 (For identification).
  - SIM (Selected Ion Monitoring): For high-sensitivity quantification.
    - Target Ions: m/z 111 (Base Peak), 137, 180 (Molecular Ion).

## Data Analysis & Interpretation

### Identification Logic

DHA is identified by a combination of Retention Index (RI) and Spectral Matching.

- Retention Index: On a DB-5ms column, DHA elutes between RI 1530 and 1555. It typically elutes after  
  
-ionone (RI ~1485) and before heavy alkanes like Hexadecane.

- Mass Spectrum Fragmentation:
  - $m/z$  180 ( ): Molecular ion, usually distinct but not the base peak.
  - $m/z$  111 (Base Peak): Result of ring cleavage and loss of the lactone ring elements. This is the primary quantifier ion.
  - $m/z$  137: Loss of isopropyl/methyl fragments.
  - $m/z$  43: Common acetyl fragment (non-specific, use only as qualifier).

## Workflow Visualization

The following diagram illustrates the analytical decision matrix for DHA analysis.

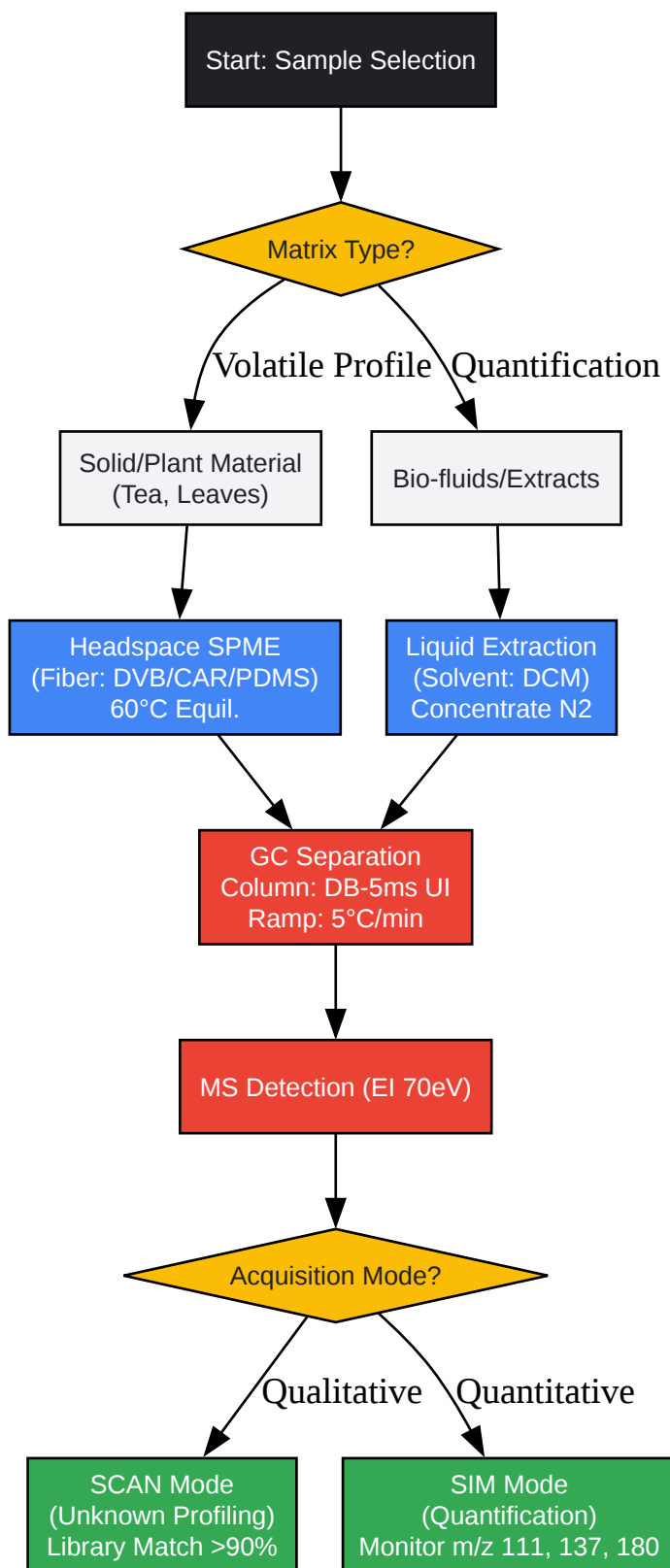

[Click to download full resolution via product page](#)

Figure 1: Analytical workflow for **Dihydroactinidiolide** selection between SPME and Liquid Extraction based on study goals.

## Validation & Quality Control

To ensure data trustworthiness (E-E-A-T), the following validation steps are mandatory:

- Linearity: Prepare calibration standards of authentic **Dihydroactinidiolide** (Sigma-Aldrich/Merck) in DCM ranging from 0.1 µg/mL to 50 µg/mL.  
  
should be > 0.995.[3]
- Internal Standard (ISTD): Use 2-Acetylthiophene or Naphthalene-d8. The ISTD corrects for injection variability and fiber competition in SPME.
- Carryover: Run a blank (pure solvent or empty vial) after high-concentration samples. Lactones can stick to the injection liner; replace the liner if ghost peaks appear.

## References

- National Center for Biotechnology Information (2025). PubChem Compound Summary for CID 16078, **Dihydroactinidiolide**. Retrieved from [\[Link\]](#)
- Sasi, M., et al. (2018). **Dihydroactinidiolide**, a natural product against Aβ<sub>25-35</sub> induced toxicity in Neuro2a cells: Synthesis, in silico and in vitro studies.[4] Bioorganic Chemistry. Retrieved from [\[Link\]](#)
- NIST Mass Spectrometry Data Center. **Dihydroactinidiolide** Mass Spectrum & Retention Indices. NIST Chemistry WebBook, SRD 69. Retrieved from [\[Link\]](#)
- Pherobase (2025). Database of Pheromones and Semiochemicals: **Dihydroactinidiolide**. Retrieved from [\[Link\]](#)
- Hamid, H. A., et al. (2017). **Dihydroactinidiolide** from thermal degradation of β-carotene.[5] Journal of Oil Palm Research. Retrieved from [\[Link\]](#)

**Need Custom Synthesis?**

BenchChem offers custom synthesis for rare earth carbides and specific isotopic labeling.

Email: [info@benchchem.com](mailto:info@benchchem.com) or [Request Quote Online](#).

## Sources

- [1. researchgate.net \[researchgate.net\]](https://www.researchgate.net)
- [2. Antioxidant activity study and GC-MS profiling of Camellia sinensis Linn - PMC \[pmc.ncbi.nlm.nih.gov\]](https://pubmed.ncbi.nlm.nih.gov/31111111/)
- [3. chromtech.net.au \[chromtech.net.au\]](https://www.chromtech.net.au)
- [4. Dihydroactinidiolide, a natural product against A \$\beta\$ 25-35 induced toxicity in Neuro2a cells: Synthesis, in silico and in vitro studies - PubMed \[pubmed.ncbi.nlm.nih.gov\]](https://pubmed.ncbi.nlm.nih.gov/31111111/)
- [5. researchgate.net \[researchgate.net\]](https://www.researchgate.net)
- To cite this document: BenchChem. [Application Note: High-Sensitivity GC-MS Profiling of Dihydroactinidiolide (DHA)]. BenchChem, [2026]. [Online PDF]. Available at: [\[https://www.benchchem.com/product/b7888491/docs#application-note-high-sensitivity-gc-ms-profiling-of-dihydroactinidiolide-dha\]](https://www.benchchem.com/product/b7888491/docs#application-note-high-sensitivity-gc-ms-profiling-of-dihydroactinidiolide-dha)

---

### Disclaimer & Data Validity:

The information provided in this document is for Research Use Only (RUO) and is strictly not intended for diagnostic or therapeutic procedures. While BenchChem strives to provide accurate protocols, we make no warranties, express or implied, regarding the fitness of this product for every specific experimental setup.

**Technical Support:** The protocols provided are for reference purposes. Unsure if this reagent suits your experiment?

**Need Industrial/Bulk Grade?** [Request Custom Synthesis Quote](#)

# BenchChem

Our mission is to be the trusted global source of essential and advanced chemicals, empowering scientists and researchers to drive progress in science and industry.

## Contact

Address: 3281 E Guasti Rd

Ontario, CA 91761, United States

Phone: (601) 213-4426

Email: [info@benchchem.com](mailto:info@benchchem.com)

[Contact our Ph.D. Support Team for a compatibility check](#)