

dATP vs. ATP: A Comprehensive Technical Guide to Their Structural and Functional Divergence

Author: BenchChem Technical Support Team. **Date:** April 2026

Compound of Interest

Compound Name:	<i>Datp</i>
CAS No.:	67460-17-7
Cat. No.:	B7881888

[Get Quote](#)

For Researchers, Scientists, and Drug Development Professionals

Abstract

Deoxyadenosine triphosphate (**dATP**) and adenosine triphosphate (ATP) are fundamental molecules in cellular biology, sharing a similar purine base and a triphosphate chain. However, a subtle structural distinction—the presence or absence of a 2'-hydroxyl group on the pentose sugar—gives rise to profoundly different functional roles. This technical guide provides an in-depth exploration of the structural and functional differences between **dATP** and ATP, with a focus on their implications in key cellular processes and drug development. We present quantitative data, detailed experimental protocols, and visual representations of signaling pathways to offer a comprehensive resource for researchers in the life sciences.

Core Structural Differences

The primary structural difference between **dATP** and ATP lies in the sugar moiety. ATP contains a ribose sugar, characterized by a hydroxyl (-OH) group at the 2' position of the pentose ring. In

contrast, **dATP** contains a deoxyribose sugar, where this 2'-hydroxyl group is replaced by a hydrogen atom.^{[1][2][3][4]} This seemingly minor alteration has significant consequences for the molecule's chemical properties, enzymatic recognition, and biological function.

Feature	dATP (Deoxyadenosine Triphosphate)	ATP (Adenosine Triphosphate)
Sugar	2'-deoxyribose	Ribose
2' Position	Hydrogen (-H)	Hydroxyl (-OH)
Primary Role	Building block of DNA ^[1]	Energy currency, building block of RNA ^[4]

Quantitative Data Summary

The distinct roles of **dATP** and ATP are reflected in their cellular concentrations and their interactions with various enzymes.

Table 2.1: Cellular Concentrations of dNTPs and ATP

The intracellular concentrations of dNTPs are tightly regulated and are significantly lower than those of ATP, especially in non-proliferating cells.^{[5][6]}

Nucleotide	Concentration Range (μM) in Mammalian Cells	Notes
dATP	7.22 - 21[7][8]	Levels fluctuate with the cell cycle, peaking in S phase.
dGTP	~5[9]	Tightly regulated to prevent mutations.
dCTP	4.96 - ~50[8][10][11]	Can increase significantly upon removal of thymidine from the medium.[11]
dTTP	24.52 - 65[6][8]	Can be synthesized from exogenous thymidine.[6]
ATP	1000 - 5000	Generally higher in normal cells compared to cancer cells. [12]

Table 2.2: Kinetic and Binding Affinity Parameters

The differential recognition of **dATP** and ATP by enzymes is critical for their specific functions.

Enzyme/Protein	Ligand	Parameter	Value	Organism/System
Ribonucleotide Reductase (RNR)				
E. coli Class Ia (Allosteric Site 1)	dATP	Kd	~6 μ M[13]	Escherichia coli
ATP	Kd	~120 μ M[13][14]	Escherichia coli	
Anaerobic RNR	dATP	Ki	74 \pm 24 μ M[15]	
ATP	KL	0.67 \pm 0.12 mM[15]		
Murine RNR (Specificity Site)	dATP	Kd	0.07 μ M[16][17]	Murine
Murine RNR (Activity Site)	dATP	Kd	1.5 μ M[16][17]	Murine
Apaf-1	dATP/ATP	-	10-fold higher affinity for dATP	Mammalian
DNA Polymerase				
Taq DNA Polymerase	dATP	Km	Varies with template and conditions	Thermus aquaticus
Human DNA Polymerase α	dATP	Km	Varies with template and conditions	Human

Functional Divergence in Key Cellular Processes

The structural differences between **dATP** and ATP dictate their distinct and sometimes opposing roles in fundamental cellular processes.

Allosteric Regulation of Ribonucleotide Reductase (RNR)

Ribonucleotide reductase is the enzyme responsible for converting ribonucleotides to deoxyribonucleotides, a rate-limiting step in DNA synthesis. The activity of RNR is tightly controlled by the allosteric binding of ATP and **dATP**.

- **ATP as an Activator:** ATP binding to the activity site of RNR generally promotes its active conformation, stimulating the production of all four dNTPs.[18]
- **dATP as an Inhibitor:** In contrast, high concentrations of **dATP** act as a potent feedback inhibitor of RNR.[18] **dATP** binding to a separate allosteric inhibitory site induces a conformational change that leads to the formation of inactive oligomeric structures. In human RNR, **dATP** stabilizes an inactive hexameric ring (α_6), while in *E. coli*, it promotes the formation of an inactive $\alpha_4\beta_4$ ring.[18][19] This inhibition is crucial for maintaining a balanced pool of dNTPs and preventing the mutagenic effects of dNTP excess.

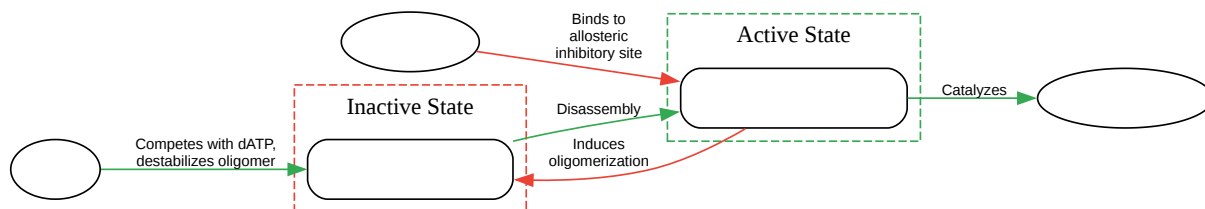

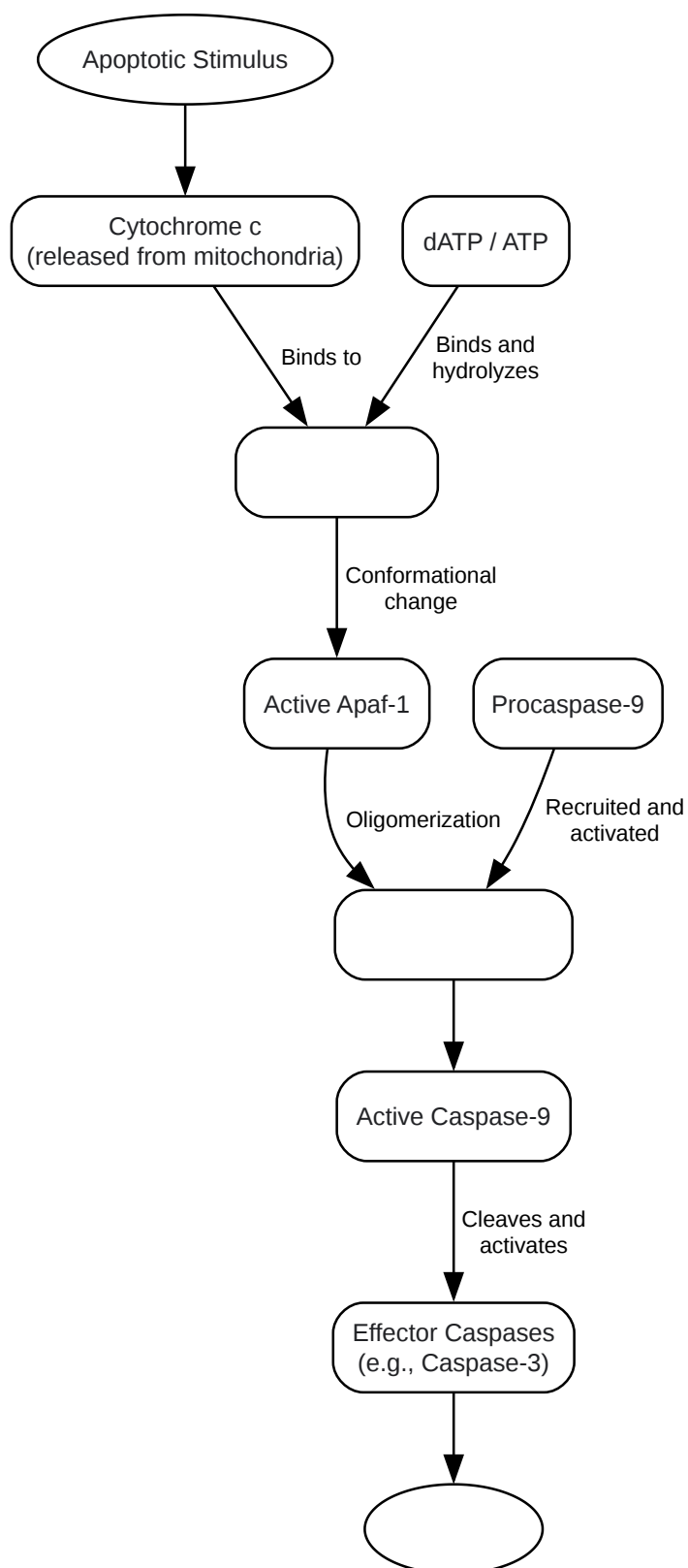

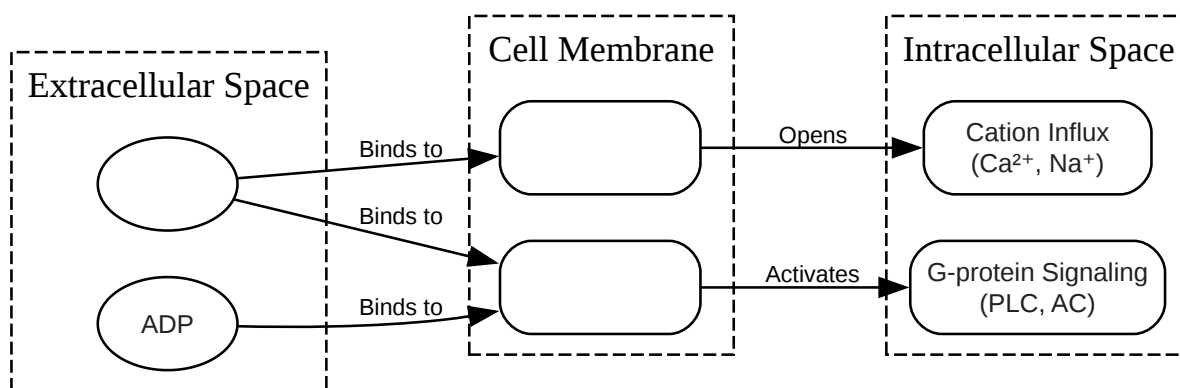

[Click to download full resolution via product page](#)

Need Custom Synthesis?

BenchChem offers custom synthesis for rare earth carbides and specific isotopic labeling.

Email: info@benchchem.com or [Request Quote Online](#).

References

- [1. What is the mechanism of Clofarabine? \[synapse.patsnap.com\]](#)
- [2. Mechanisms of anti-cancer action and pharmacology of clofarabine - PubMed \[pubmed.ncbi.nlm.nih.gov\]](#)
- [3. researchgate.net \[researchgate.net\]](#)
- [4. researchgate.net \[researchgate.net\]](#)
- [5. Quantitation of cellular deoxynucleoside triphosphates - PMC \[pmc.ncbi.nlm.nih.gov\]](#)
- [6. Are DNA precursors concentrated at replication sites? - PubMed \[pubmed.ncbi.nlm.nih.gov\]](#)
- [7. researchgate.net \[researchgate.net\]](#)
- [8. researchgate.net \[researchgate.net\]](#)
- [9. researchgate.net \[researchgate.net\]](#)
- [10. Deoxycytidine triphosphate \(dCTP\) | nucleoside triphosphate and a precursor for DNA synthesis | CAS# 2056-98-6 | InvivoChem \[invivochem.com\]](#)

- [11. Lack of specific correlation of the deoxycytidine triphosphate pool level with rate of DNA synthesis - PubMed \[pubmed.ncbi.nlm.nih.gov\]](#)
- [12. Mechanism for ribonucleotide reductase inactivation by the anticancer drug gemcitabine - PubMed \[pubmed.ncbi.nlm.nih.gov\]](#)
- [13. What is the mechanism of Gemcitabine? \[synapse.patsnap.com\]](#)
- [14. How ATP and dATP Act as Molecular Switches to Regulate Enzymatic Activity in the Prototypical Bacterial Class Ia Ribonucleotide Reductase - PMC \[pmc.ncbi.nlm.nih.gov\]](#)
- [15. Activity modulation in anaerobic ribonucleotide reductases: nucleotide binding to the ATP-cone allosterically mediates substrate binding to the active site \[elifesciences.org\]](#)
- [16. pubs.acs.org \[pubs.acs.org\]](#)
- [17. Allosteric Inhibition of Human Ribonucleotide Reductase by dATP Entails the Stabilization of a Hexamer - PMC \[pmc.ncbi.nlm.nih.gov\]](#)
- [18. selleckchem.com \[selleckchem.com\]](#)
- [19. portlandpress.com \[portlandpress.com\]](#)
- [To cite this document: BenchChem. \[dATP vs. ATP: A Comprehensive Technical Guide to Their Structural and Functional Divergence\]. BenchChem, \[2026\]. \[Online PDF\]. Available at: \[https://www.benchchem.com/product/b7881888/docs#datp-vs-atp-a-comprehensive-technical-guide-to-their-structural-and-functional-divergence\]](#)

Disclaimer & Data Validity:

The information provided in this document is for Research Use Only (RUO) and is strictly not intended for diagnostic or therapeutic procedures. While BenchChem strives to provide accurate protocols, we make no warranties, express or implied, regarding the fitness of this product for every specific experimental setup.

Technical Support: The protocols provided are for reference purposes. Unsure if this reagent suits your experiment?

Need Industrial/Bulk Grade? [Request Custom Synthesis Quote](#)

BenchChem

Our mission is to be the trusted global source of essential and advanced chemicals, empowering scientists and researchers to drive progress in science and industry.

Contact

Address: 3281 E Guasti Rd

Ontario, CA 91761, United States

Phone: (601) 213-4426

Email: info@benchchem.com

[Contact our Ph.D. Support Team for a compatibility check](#)