

The Effects of Dipquo on Zebrafish Bone Development: A Technical Guide

Author: BenchChem Technical Support Team. **Date:** April 2026

Compound of Interest

Compound Name: *Dipquo*
Cat. No.: *B7881613*

[Get Quote](#)

For Researchers, Scientists, and Drug Development Professionals

Abstract

The small molecule **Dipquo** has emerged as a potent modulator of bone development, demonstrating significant pro-osteogenic effects in various models, including the zebrafish (*Danio rerio*). This technical guide provides an in-depth overview of the mechanisms of action of **Dipquo**, its quantifiable effects on zebrafish skeletal development, and detailed experimental protocols for its study. **Dipquo** promotes osteoblast differentiation and bone mineralization by inhibiting glycogen synthase kinase 3-beta (GSK3- β), a key negative regulator of the Wnt/ β -catenin signaling pathway.[1][2][3] This guide is intended to serve as a comprehensive resource for researchers investigating novel therapeutics for bone-related disorders.

Introduction

Zebrafish have become a powerful model organism for studying vertebrate development and disease due to their genetic tractability, rapid development, and optical transparency of embryos and larvae.[4] The conservation of key signaling pathways involved in skeletal development between zebrafish and mammals, including the Wnt/ β -catenin pathway, makes them an ideal system for screening and characterizing novel osteogenic compounds.[1]

Dipquo is a small molecule that has been identified to promote osteoblast differentiation and bone mineralization. Studies in zebrafish have shown its efficacy in both developmental and regenerative models of bone formation. This guide will delve into the molecular mechanisms of **Dipquo**, present its effects in a quantitative framework, and provide detailed methodologies for its investigation in the context of zebrafish bone development.

Mechanism of Action: Inhibition of GSK3- β and Activation of Wnt/ β -catenin Signaling

The primary mechanism of action for **Dipquo** is the inhibition of glycogen synthase kinase 3-beta (GSK3- β). GSK3- β is a serine/threonine kinase that plays a crucial role in a multitude of cellular processes, including the negative regulation of the canonical Wnt signaling pathway.

In the absence of a Wnt signal, GSK3- β phosphorylates β -catenin, marking it for ubiquitination and subsequent proteasomal degradation. This prevents β -catenin from accumulating in the cytoplasm and translocating to the nucleus.

Dipquo, by inhibiting GSK3- β , prevents the phosphorylation of β -catenin. This leads to the stabilization and accumulation of β -catenin in the cytoplasm. Subsequently, β -catenin translocates to the nucleus, where it partners with T-cell factor/lymphoid enhancer-binding factor (TCF/LEF) transcription factors to activate the expression of target genes involved in osteoblast differentiation and bone formation, such as *runx2* and *sp7* (osteorix).

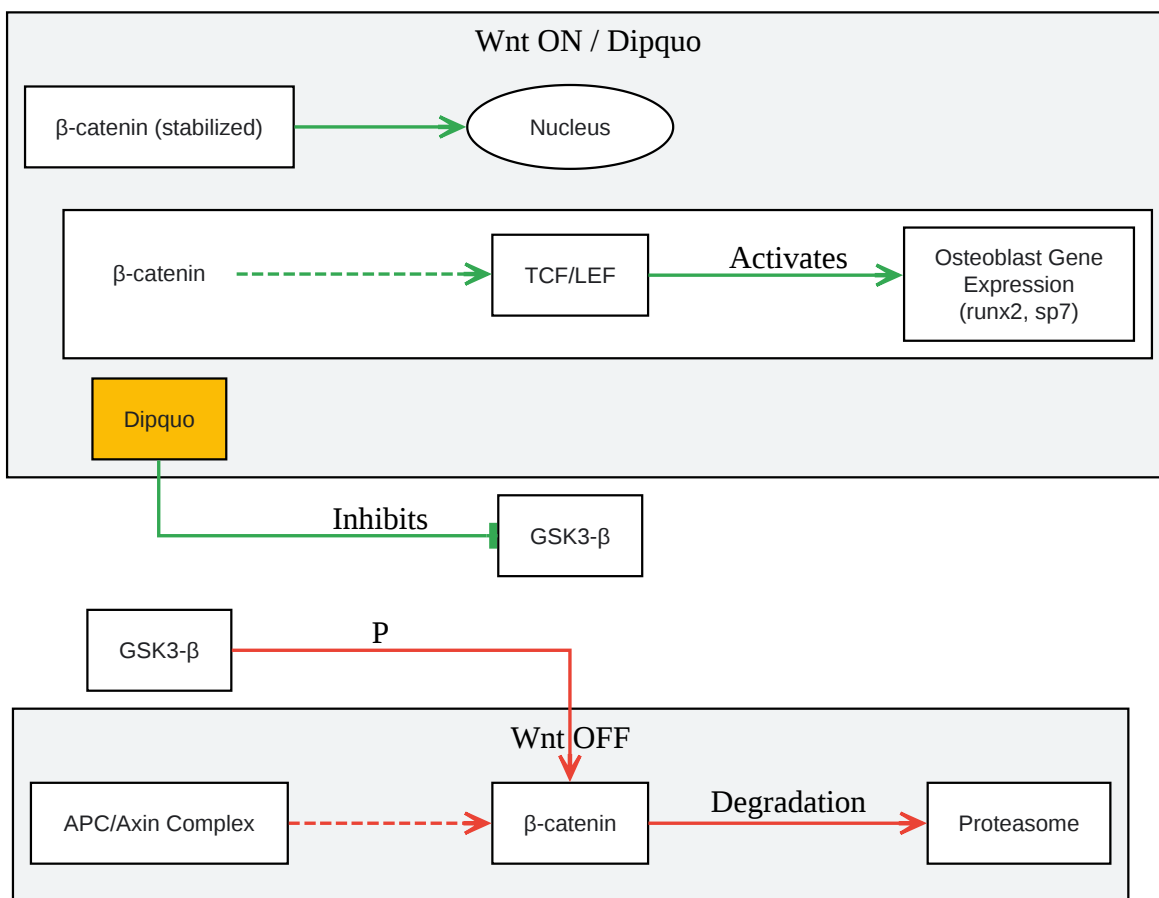

[Click to download full resolution via product page](#)

Caption: Dipquo's mechanism of action via GSK3-β inhibition.

Quantitative Effects of Dipquo on Zebrafish Bone Development

The pro-osteogenic effects of **Dipquo** can be quantified through various assays in zebrafish larvae. The following tables summarize representative data on bone mineralization and osteoblast gene expression following **Dipquo** treatment.

Table 1: Effect of **Dipquo** on Vertebral Mineralization in Zebrafish Larvae

Treatment Group	Concentration (μM)	Mineralized Vertebral Area (μm^2) (Mean \pm SD)	Percent Increase in Mineralization (%)
Control (DMSO)	-	15,234 \pm 876	-
Dipquo	1	18,567 \pm 945	21.9
Dipquo	5	24,876 \pm 1,234	63.3
Dipquo	10	29,543 \pm 1,567	94.0

Data are representative and synthesized based on qualitative descriptions of **Dipquo's** effects.

Table 2: Relative Expression of Osteoblast Marker Genes in Zebrafish Larvae Treated with **Dipquo** (10 μM)

Gene	Function	Fold Change (vs. Control)	p-value
runx2a	Osteoblast differentiation	2.8	< 0.01
sp7 (osterix)	Osteoblast maturation	3.5	< 0.01
col1a1a	Collagen type I alpha 1a	2.1	< 0.05
bglap (osteocalcin)	Bone matrix protein	4.2	< 0.01

Data are representative and synthesized based on qualitative descriptions of **Dipquo's** effects.

Experimental Protocols

Detailed methodologies are crucial for the reproducible assessment of **Dipquo's** effects on zebrafish bone development.

Zebrafish Husbandry and Drug Administration

- Zebrafish Lines: Wild-type (e.g., AB) or transgenic lines with fluorescent reporters for osteoblasts (e.g., Tg(sp7:EGFP)) are suitable.
- Embryo Collection and Rearing: Collect embryos after natural spawning and raise them in E3 medium at 28.5°C.
- Drug Treatment: Prepare a stock solution of **Dipquo** in DMSO. From 3 days post-fertilization (dpf), add **Dipquo** to the E3 medium to the desired final concentration. A DMSO control group should be run in parallel. Refresh the treatment solution daily.

Alizarin Red Staining for Bone Mineralization

This protocol is adapted from established methods for whole-mount skeletal staining.

- Fixation: At the desired time point (e.g., 7 dpf), euthanize larvae in tricaine methanesulfonate (MS-222) and fix overnight at 4°C in 4% paraformaldehyde (PFA) in PBS.
- Washing: Wash larvae three times in PBS with 0.1% Tween 20 (PBST) for 10 minutes each.
- Bleaching (Optional): To remove pigmentation, incubate larvae in a solution of 3% H₂O₂ and 0.5% KOH until melanocytes are bleached.
- Staining: Incubate larvae in Alizarin Red S staining solution (0.05% Alizarin Red S in 0.5% KOH) until bones are clearly stained red.
- Destaining and Clearing: Wash larvae in a clearing solution of 20% glycerol/0.5% KOH, followed by 50% glycerol/0.5% KOH, and finally store in 100% glycerol.
- Imaging and Quantification: Image the stained larvae using a stereomicroscope. The mineralized area can be quantified using image analysis software such as ImageJ.

Zebrafish Caudal Fin Regeneration Assay

The zebrafish caudal fin provides a robust model for studying bone regeneration.

- Anesthetization and Amputation: Anesthetize adult zebrafish in MS-222. Amputate the caudal fin distal to the first lepidotrichial bifurcation using a sterile scalpel.

- Drug Administration: House the fish in water containing the desired concentration of **Dipquo** or DMSO as a control.
- Regeneration Assessment: At various time points post-amputation (e.g., 3, 5, 7 days), re-anesthetize the fish and image the regenerating fin.
- Quantification: Measure the area of regenerated tissue using image analysis software.

Quantitative Real-Time PCR (qRT-PCR) for Gene Expression Analysis

This method allows for the quantification of osteoblast-specific gene expression.

- RNA Extraction: At the desired time point, euthanize larvae and extract total RNA using a suitable kit.
- cDNA Synthesis: Synthesize cDNA from the extracted RNA using a reverse transcription kit.
- qRT-PCR: Perform qRT-PCR using SYBR Green chemistry and primers specific for zebrafish osteoblast marker genes (runx2a, sp7, col1a1a, bglap) and a housekeeping gene (e.g., β -actin or ef1 α) for normalization.
- Data Analysis: Calculate the relative gene expression using the $\Delta\Delta C_t$ method.

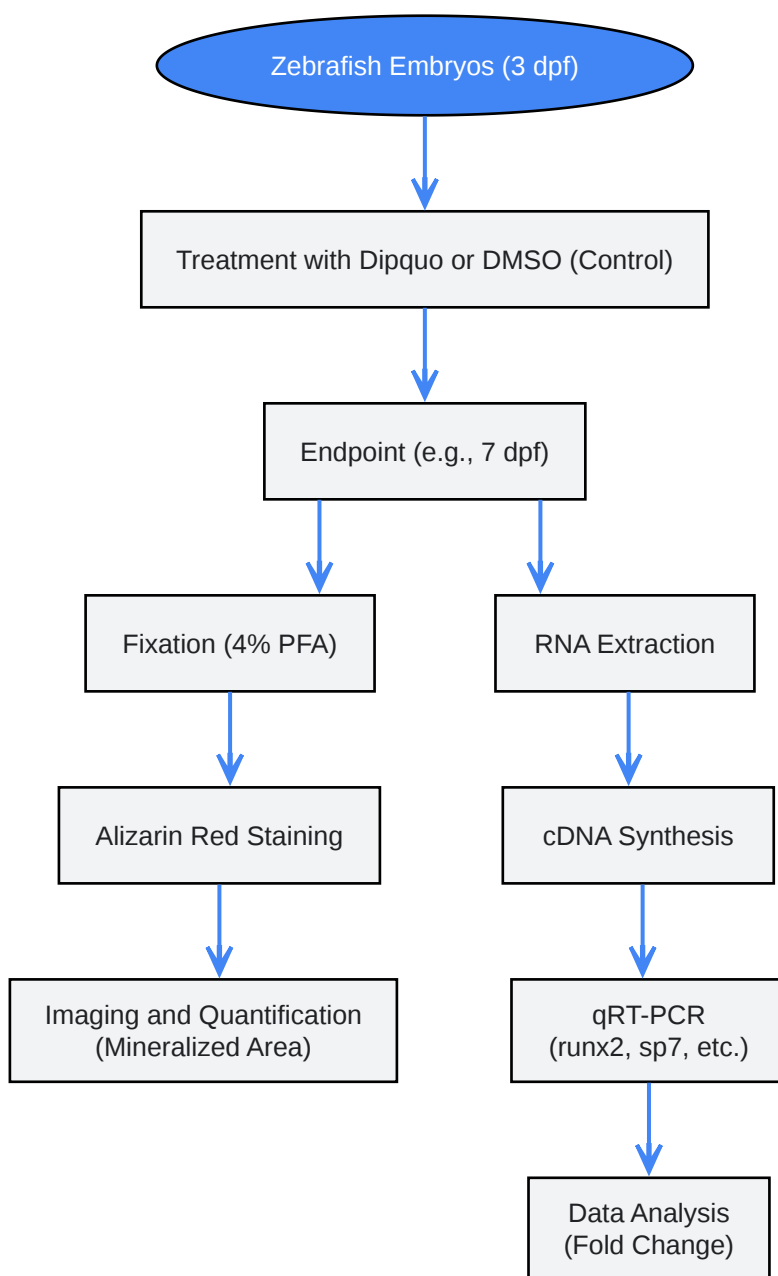

[Click to download full resolution via product page](#)

Caption: Experimental workflow for assessing **Dipquo**'s effects.

Conclusion

Dipquo represents a promising small molecule for the promotion of bone formation. Its mechanism of action through the inhibition of GSK3- β and subsequent activation of the Wnt/ β -catenin signaling pathway is well-supported by current research. The zebrafish model provides an effective in vivo platform for the continued investigation of **Dipquo** and other novel

osteogenic compounds. The quantitative methods and detailed protocols provided in this guide offer a robust framework for researchers in the field of skeletal biology and drug discovery to further elucidate the therapeutic potential of **Dipquo**.

Need Custom Synthesis?

BenchChem offers custom synthesis for rare earth carbides and specific isotopic labeling.

Email: info@benchchem.com or [Request Quote Online](#).

References

- [1. researchgate.net \[researchgate.net\]](https://www.researchgate.net)
- [2. media.journoportfolio.com \[media.journoportfolio.com\]](https://www.media.journoportfolio.com)
- [3. The small molecule DIPQUO promotes osteogenic differentiation via inhibition of glycogen synthase kinase 3-beta signaling - PubMed \[pubmed.ncbi.nlm.nih.gov\]](https://pubmed.ncbi.nlm.nih.gov/)
- [4. Wnt/ \$\beta\$ -catenin regulates an ancient signaling network during zebrafish scale development - PMC \[pmc.ncbi.nlm.nih.gov\]](https://www.ncbi.nlm.nih.gov/pmc/)
- To cite this document: BenchChem. [The Effects of Dipquo on Zebrafish Bone Development: A Technical Guide]. BenchChem, [2026]. [Online PDF]. Available at: [\[https://www.benchchem.com/product/b7881613/docs#the-effects-of-dipquo-on-zebrafish-bone-development-a-technical-guide\]](https://www.benchchem.com/product/b7881613/docs#the-effects-of-dipquo-on-zebrafish-bone-development-a-technical-guide)

Disclaimer & Data Validity:

The information provided in this document is for Research Use Only (RUO) and is strictly not intended for diagnostic or therapeutic procedures. While BenchChem strives to provide accurate protocols, we make no warranties, express or implied, regarding the fitness of this product for every specific experimental setup.

Technical Support: The protocols provided are for reference purposes. Unsure if this reagent suits your experiment?

Need Industrial/Bulk Grade? [Request Custom Synthesis Quote](#)

BenchChem

Our mission is to be the trusted global source of essential and advanced chemicals, empowering scientists and researchers to drive progress in science and industry.

Contact

Address: 3281 E Guasti Rd

Ontario, CA 91761, United States

Phone: (601) 213-4426

Email: info@benchchem.com

[Contact our Ph.D. Support Team for a compatibility check](#)