

# Comparative Guide: Mass Spectrometry Characterization of 3,5-Difluoro-4- phenoxybenzaldehyde

**Author:** BenchChem Technical Support Team. **Date:** May 2026

## Compound of Interest

Compound Name: 3,5-Difluoro-4-  
phenoxybenzaldehyde

Cat. No.: B7877773

[Get Quote](#)

## Executive Summary

This technical guide provides an in-depth analysis of the mass spectrometry (MS) fragmentation patterns of **3,5-difluoro-4-phenoxybenzaldehyde**, a critical intermediate in the synthesis of agrochemicals (e.g., fluxapyroxad) and pharmaceutical ethers. Unlike standard spectral libraries which often lack specific fluorinated intermediates, this guide synthesizes first-principles fragmentation logic with comparative data from non-fluorinated analogs (4-phenoxybenzaldehyde).

We compare two primary analytical "alternatives" for characterization: Electron Ionization (EI) for structural elucidation and Electrospray Ionization (ESI) for molecular weight confirmation and purity analysis.

## Part 1: Structural Profile & Theoretical Basis

Feature	Specification
Compound Name	3,5-Difluoro-4-phenoxybenzaldehyde
Formula	C <sub>13</sub> H <sub>8</sub> F <sub>2</sub> O <sub>2</sub>
Exact Mass (Monoisotopic)	234.05 Da
Key Functional Groups	Aldehyde (-CHO), Diaryl Ether (Ar-O-Ar), Fluorine substituents (x2)
Structural Context	The two fluorine atoms at the 3,5-positions exert a strong electron-withdrawing inductive effect (-I), significantly altering the charge localization compared to the non-fluorinated analog.

## Part 2: Comparative Analysis of Analytical Alternatives

For researchers validating this compound, choosing the correct ionization mode is critical. Below is a performance comparison of the two standard methodologies.

### Alternative 1: Electron Ionization (EI) - Hard Ionization[1]

- Primary Use: Structural fingerprinting, impurity identification.
- Mechanism: 70 eV electron impact induces extensive fragmentation.[1]
- Performance Verdict: Superior for Structure. The radical cation ( ) is formed but often fragments further, providing a "fingerprint" that confirms the position of the fluorine atoms relative to the ether linkage.
- Key Limitation: The molecular ion ( ) may be weak if the aldehyde proton is lost rapidly.

### Alternative 2: Electrospray Ionization (ESI) - Soft Ionization[1]

- Primary Use: Quantitation (LC-MS/MS), molecular weight confirmation.
- Mechanism: Formation of quasimolecular ions (  $[M+H]^+$  or  $[M+Na]^+$  ).
- Performance Verdict: Superior for Purity. Produces a clean parent peak with minimal fragmentation unless Collision Induced Dissociation (CID) is applied.
- Key Limitation: Lacks the rich fragment ions needed to distinguish subtle regioisomers without MS/MS experiments.

## Part 3: Fragmentation Mechanics (EI Spectrum)

The fragmentation of **3,5-difluoro-4-phenoxybenzaldehyde** follows distinct pathways governed by the stability of the aromatic rings and the ether linkage.

### The Molecular Ion ( , m/z 234)

Under EI (70 eV), the molecule forms a radical cation. Due to the aromatic stabilization, the molecular ion is usually observable, though often not the base peak.

### Alpha-Cleavage (Aldehyde Characteristic)

- Loss of H (M-1): Cleavage of the aldehydic hydrogen yields the acylium ion (m/z 233). This is a diagnostic peak for aldehydes.[2]
- Loss of CHO (M-29): Elimination of the formyl radical yields the 3,5-difluoro-4-phenoxyphenyl cation (m/z 205).
  - Comparison Note: In non-fluorinated 4-phenoxybenzaldehyde, this peak appears at m/z 169. The +36 Da shift (2 x 19 Da for Fluorine - 2 x 1 Da for Hydrogen) confirms the presence of two fluorine atoms on the central ring.

### Ether Cleavage (The "Phenoxy" Break)

The ether bond is the second weak point. Fragmentation here depends on charge retention:

- Path A (Charge on Phenoxy): Formation of the phenyl cation ( $m/z$  77) or phenoxy cation ( $m/z$  93). This is often the base peak in diaryl ethers because the fluorinated ring is electron-deficient (due to F atoms), destabilizing the cation on that side.
- Path B (Charge on Difluorophenyl): Formation of the 3,5-difluoro-4-hydroxyphenyl cation is less favored but may appear at  $m/z$  141 (rearrangement) or  $m/z$  125 (direct cleavage).

## Diagnostic Ion Table

$m/z$ (Nominal)	Ion Identity	Mechanism	Relative Intensity (Predicted)
234		Molecular Ion	Medium (20-40%)
233		Acylium (Loss of H)	High (80-90%)
205		Loss of CHO	Medium-High (60-80%)
77		Phenyl Cation	Base Peak (100%)
51		Ring Fragmentation	High (50-70%)

## Part 4: Visualization of Signaling Pathways

The following diagram illustrates the fragmentation logic, highlighting the competition between aldehyde alpha-cleavage and ether bond rupture.

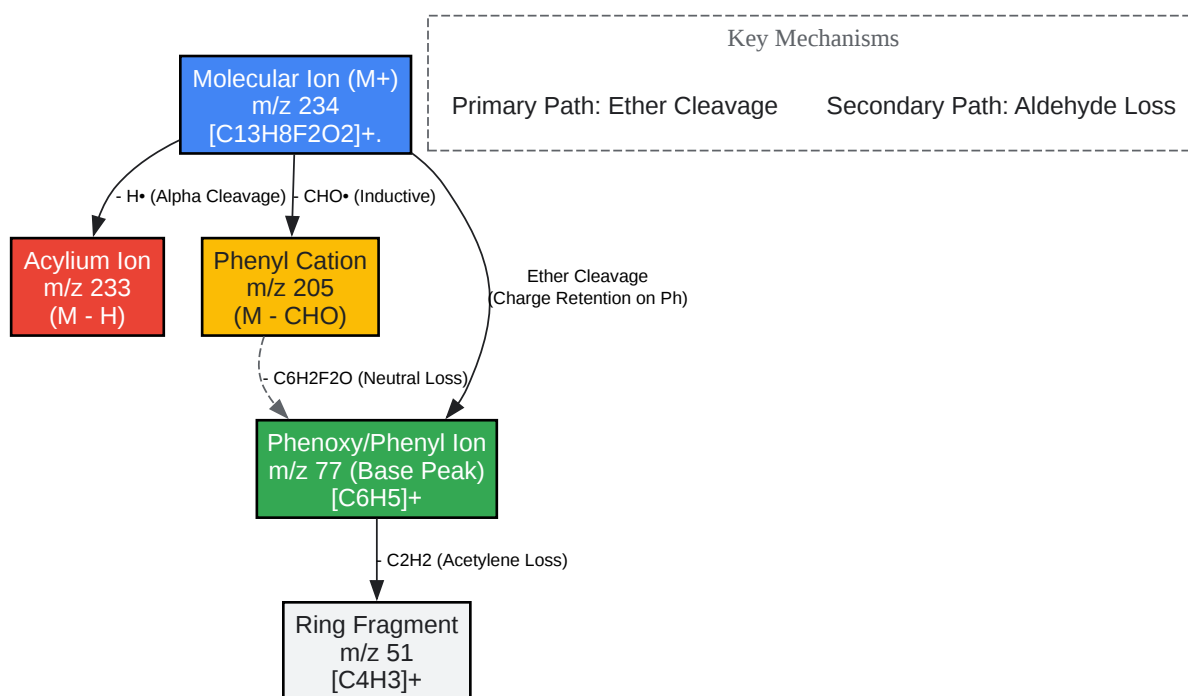

[Click to download full resolution via product page](#)

Figure 1: Predicted EI fragmentation pathway for **3,5-difluoro-4-phenoxybenzaldehyde**, showing the competition between carbonyl loss and ether cleavage.

## Part 5: Experimental Protocols

To ensure reproducibility, the following protocols are recommended for characterizing this compound.

### Protocol A: GC-MS (Structural Identification)

- Instrument: Agilent 7890/5977 (or equivalent).
- Column: DB-5ms or equivalent (30m x 0.25mm x 0.25µm).

- Inlet: Split mode (20:1), 250°C.
- Carrier Gas: Helium at 1.0 mL/min (Constant Flow).
- Oven Program:
  - Hold 60°C for 1 min.
  - Ramp 20°C/min to 280°C.
  - Hold 5 min.
- MS Source: Electron Ionization (70 eV), 230°C.
- Scan Range: m/z 40–400.
- Validation Check: Ensure the m/z 205/77 ratio is consistent. The absence of m/z 205 suggests oxidation to the carboxylic acid.

## Protocol B: LC-MS/MS (Purity & Quantitation)

- Instrument: Triple Quadrupole (e.g., Sciex 6500 or Thermo Altis).
- Ionization: ESI Positive Mode (ESI+).
- Mobile Phase:
  - A: Water + 0.1% Formic Acid.
  - B: Acetonitrile + 0.1% Formic Acid.
- Gradient: 5% B to 95% B over 8 minutes.
- MRM Transitions (for Quantitation):
  - Quantifier: 235.0
  - 77.0 (Loss of difluorobenzaldehyde neutral).

- Qualifier: 235.0

217.0 (Loss of water from hydrate form/rearrangement).

## Workflow Diagram



[Click to download full resolution via product page](#)

Figure 2: Standardized workflow for mass spectrometric analysis of fluorinated benzaldehydes.

## References

- NIST Mass Spectrometry Data Center. "Mass Spectrum of 4-Phenoxybenzaldehyde (Analog Control)." NIST Chemistry WebBook, SRD 69. Available at: [\[Link\]](#)
- McLafferty, F. W., & Tureček, F. (1993).<sup>[3]</sup> Interpretation of Mass Spectra. University Science Books. (Standard reference for Alpha-cleavage and rearrangement mechanisms).
- Gross, J. H. (2017). Mass Spectrometry: A Textbook. Springer.
- PubChem. "3-Phenoxybenzaldehyde Compound Summary." National Library of Medicine. Available at: [\[Link\]](#)

### Need Custom Synthesis?

BenchChem offers custom synthesis for rare earth carbides and specific isotopic labeling.

Email: [info@benchchem.com](mailto:info@benchchem.com) or [Request Quote Online](#).

## Sources

- 1. [peptid.chem.elte.hu](http://peptid.chem.elte.hu) [[peptid.chem.elte.hu](http://peptid.chem.elte.hu)]
- 2. [chemistry.miamioh.edu](http://chemistry.miamioh.edu) [[chemistry.miamioh.edu](http://chemistry.miamioh.edu)]
- 3. [thiele.ruc.dk](http://thiele.ruc.dk) [[thiele.ruc.dk](http://thiele.ruc.dk)]

- To cite this document: BenchChem. [Comparative Guide: Mass Spectrometry Characterization of 3,5-Difluoro-4-phenoxybenzaldehyde]. BenchChem, [2026]. [Online PDF]. Available at: [<https://www.benchchem.com/product/b7877773/docs#comparative-guide-mass-spectrometry-characterization-of-3-5-difluoro-4-phenoxybenzaldehyde>]

---

### Disclaimer & Data Validity:

The information provided in this document is for Research Use Only (RUO) and is strictly not intended for diagnostic or therapeutic procedures. While BenchChem strives to provide accurate protocols, we make no warranties, express or implied, regarding the fitness of this product for every specific experimental setup.

**Technical Support:** The protocols provided are for reference purposes. Unsure if this reagent suits your experiment?

**Need Industrial/Bulk Grade?** [Request Custom Synthesis Quote](#)

## BenchChem

Our mission is to be the trusted global source of essential and advanced chemicals, empowering scientists and researchers to drive progress in science and industry.

### Contact

Address: 3281 E Guasti Rd

Ontario, CA 91761, United States

Phone: (601) 213-4426

Email: [info@benchchem.com](mailto:info@benchchem.com)

[Contact our Ph.D. Support Team for a compatibility check](#)