

Application Note: Advanced Continuous Flow Methodologies for Fluorinated Benzaldehyde Transformations

Author: BenchChem Technical Support Team. **Date:** April 2026

Compound of Interest

Compound Name: 2-Fluoro-5-(3-methoxyphenyl)benzaldehyde

Cat. No.: B7860237

[Get Quote](#)

Target Audience: Process Chemists, Medicinal Chemists, and Chemical Engineers in Drug Development
Document Type: Technical Guide & Experimental Protocols

Executive Summary

Fluorinated benzaldehydes are highly versatile building blocks in medicinal chemistry, frequently utilized to introduce lipophilic, metabolically stable fluorophenyl moieties into active pharmaceutical ingredients (APIs). However, their derivatization often involves highly reactive intermediates, extreme temperatures, or multiphasic mixtures that pose severe scalability and safety challenges in traditional batch reactors.

This application note details field-proven continuous flow chemistry methods to overcome these bottlenecks. By leveraging enhanced mass and heat transfer, precise residence time control, and specialized reactor designs (e.g., oscillatory flow), researchers can safely execute cryogenic umpolung additions, high-temperature cyclizations, and heterogeneous micellar catalysis involving fluorinated benzaldehydes.

Overcoming Organolithium Instability: Cryogenic Umpolung Addition

Scientific Rationale

The synthesis of complex spirocyclic scaffolds, such as the SHP2 inhibitor GDC-1971 (migoprotafib), relies on the umpolung 1,2-addition of a 2-fluorobenzaldehyde derivative to a piperidone. In batch, the Katritzky benzotriazole hemiaminal derived from 2-fluorobenzaldehyde is deprotonated by *n*-butyllithium to form a benzylic organolithium intermediate. This species is notoriously unstable, rapidly decomposing even at strict cryogenic temperatures (-78 °C) [1].

Transitioning to a fast-mixing plug-flow reactor eliminates this bottleneck. The continuous process allows for the consistent generation and near-instantaneous consumption of the fleeting organolithium intermediate before decomposition can occur, enabling multi-kilogram scale-up without the need for massive cryogenic pilot vessels [1].

Workflow Visualization

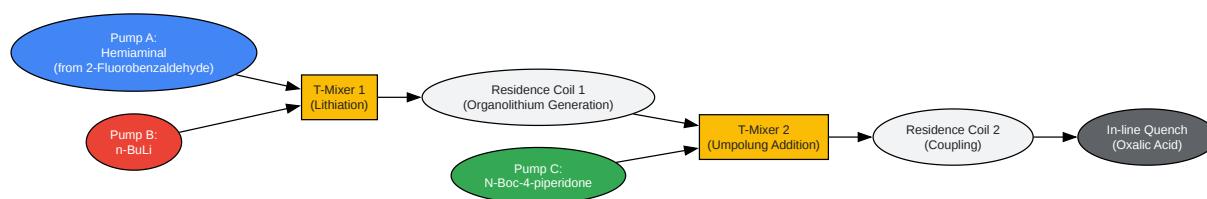

[Click to download full resolution via product page](#)

Continuous plug-flow setup for the cryogenic umpolung addition of 2-fluorobenzaldehyde derivatives.

Experimental Protocol: Plug-Flow Umpolung Addition

- System Preparation: Prime a dual T-mixer plug-flow system with anhydrous THF. Submerge Residence Coil 1 (RC1) and Residence Coil 2 (RC2) in a cooling bath set to -20 °C.
- Feed Solutions:

- Feed A: 0.5 M solution of the 2-fluorobenzaldehyde Katritzky hemiaminal in THF.
- Feed B: 2.5 M n-BuLi in hexanes.
- Feed C: 0.6 M solution of N-Boc-4-piperidone in THF.
- Execution:
 - Pump Feed A and Feed B into T-Mixer 1. The flow rates must be calibrated to achieve a 1:1.05 molar ratio of hemiaminal to n-BuLi.
 - Allow the lithiation to occur in RC1 with a residence time (τ) of exactly 15 seconds.
 - Route the effluent of RC1 into T-Mixer 2, simultaneously introducing Feed C (1.1 equivalents relative to Feed A).
 - Allow the coupling to proceed in RC2 with a τ of 60 seconds.
- Quench & Isolation: Direct the output of RC2 directly into a stirred flask containing a 10% aqueous oxalic acid solution to collapse the tetrahedral intermediate into the desired 4-(2-fluorobenzoyl)-4-hydroxypiperidine.

Table 1: Flow vs. Batch Comparison for Umpolung Addition

Parameter	Traditional Batch	Continuous Plug-Flow
Operating Temperature	-78 °C (Strict Cryogenic)	-20 °C (Mild Cryogenic)
Intermediate Stability	Rapid decomposition	Controlled, immediate consumption
Mixing Efficiency	Poor at pilot scale	Excellent (Micro-channel T-mixers)
Yield	Variable (<60%)	High, highly reproducible (>85%)

Process Intensification: High-Temperature

Synthesis of 1H-Indazoles

Scientific Rationale

1H-indazoles are vital pharmacophores. A direct route to synthesize them involves the condensation of o-fluorobenzaldehydes (e.g., 4-bromo-2,6-difluorobenzaldehyde) with hydrazines (e.g., tert-butyl carbazate) followed by intramolecular S_NAr cyclization. In batch, handling hydrazine derivatives at the elevated temperatures required for the cyclization poses severe explosion and exposure risks [2].

Flow chemistry allows the reaction to be safely superheated above the solvent's boiling point. The microreactor's high surface-area-to-volume ratio ensures rapid heat transfer, while the minimal active volume mitigates thermal runaway risks [2].

Mechanistic Pathway

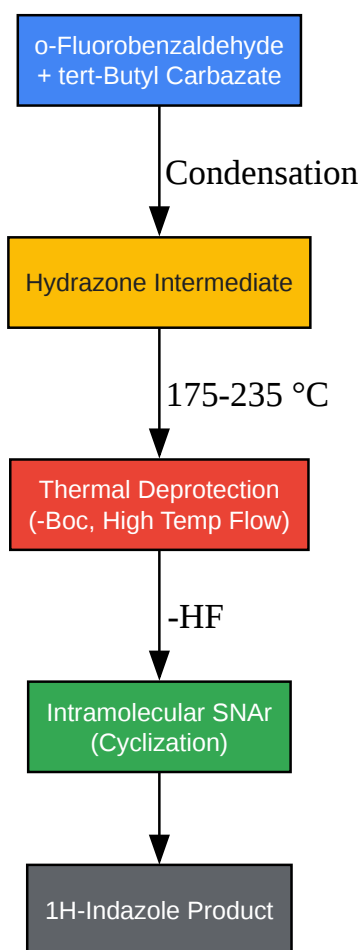

[Click to download full resolution via product page](#)

Mechanistic pathway for continuous-flow synthesis of 1H-indazoles from o-fluorobenzaldehydes.

Experimental Protocol: High-Temperature Cyclization

- **Feed Preparation:** Prepare a single-feed solution containing 4-bromo-2,6-difluorobenzaldehyde (1.0 M) and tert-butyl carbazate (2.0 M) in a high-boiling solvent (e.g., NMP or DMSO).
- **Reactor Setup:** Utilize a robust metal-alloy continuous-flow microreactor equipped with a back-pressure regulator (BPR) set to 250 psi to prevent solvent boiling.
- **Optimization Execution:** Pump the mixture through the heated reactor zone. As shown in Table 2, elevating the temperature accelerates the thermal deprotection of the Boc-group and subsequent cyclization.
- **Collection:** Pass the effluent through a cooling loop before depressurization across the BPR.

Table 2: Temperature Optimization for 1H-Indazole Synthesis in Flow [2]

Temperature (°C)	Residence Time (min)	Target Product Area %	Observation
175	15	53.7%	Incomplete cyclization
200	15	~75.0%	Moderate conversion
235	15	92.8%	Optimal thermal deprotection & cyclization
>235	15	84.7%	Hydroxylation side reactions due to water formation

Multiphase Handling: Reductive Amination in Micellar Media

Scientific Rationale

Aqueous micellar chemistry is a sustainable alternative to organic solvents, but it creates complex multiphasic mixtures. When combining this with heterogeneous catalysts (like Pd/C) for the reductive amination of 4-fluorobenzaldehyde, traditional packed-bed flow reactors immediately clog [3].

To solve this, an Oscillatory Plug Flow Reactor (OFR) is employed. The OFR applies a pulsed motion to the fluid, creating intense radial mixing via eddy currents. This keeps the Pd/C catalyst perfectly suspended in the aqueous surfactant mixture while ensuring excellent mass transfer between the aqueous phase, the neat 4-fluorobenzaldehyde, and the amine [3].

Reactor Visualization

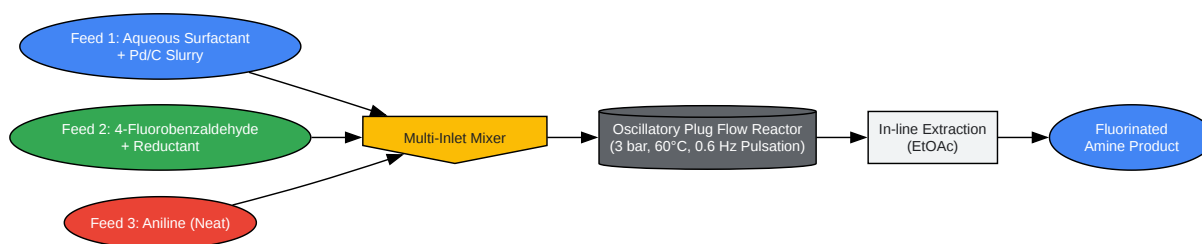

[Click to download full resolution via product page](#)

Three-feed oscillatory flow reactor system for heterogeneous reductive amination.

Experimental Protocol: OFR Reductive Amination

- Feed Configuration (Modified Three-Feed System):
 - Feed 1: Aqueous surfactant solution (e.g., TPGS-750-M) containing suspended Pd/C catalyst.
 - Feed 2: Neat mixture of 4-fluorobenzaldehyde and the liquid reductant.

- Feed 3: Neat aniline. (Note: Separating the aldehyde and aniline prevents background imine formation in the feed lines, which alters viscosity and density over time [3]).
- Reactor Parameters: Set the OFR to 60 °C and maintain a system pressure of 3 bar. Set the pulsator to a 0.24 mL amplitude (~50%) and a 0.6 Hz frequency (20%)[3].
- Execution: Pump all three feeds into the multi-inlet mixer at a combined flow rate of 500 $\mu\text{L}/\text{min}$. The pulsation ensures the Pd/C slurry does not settle or foul the reactor walls.
- Workup: Collect the product mixture under steady-state conditions and extract in-line with a minimal volume of ethyl acetate (EtOAc).

Analytical Integration: Real-Time Mechanistic Monitoring

When optimizing flow processes involving fluorinated benzaldehydes, the fluorine atom serves as an ideal spectroscopic handle. Integrating benchtop ^{19}F NMR spectroscopy inline allows for real-time reaction monitoring without the solvent suppression issues common in ^1H NMR [4].

For example, during the multicomponent Biginelli condensation of fluorinated benzaldehydes, inline ^{19}F NMR can distinguish between the Knoevenagel adduct and enamine intermediates based on distinct chemical shifts (e.g., $\delta = -75.35$ ppm for the Ar-F bond), allowing operators to adjust flow rates and temperatures dynamically to favor the desired mechanistic pathway [4].

References

- Pompeo, M. M., et al. "Umpolung Flow Chemistry for the Synthesis of a 3-Oxo-3H-spiro[benzofuran-2,4'-piperidine] Building Block." *Journal of Organic Chemistry*, American Chemical Society, 2024. Available at:[\[Link\]](#)
- "THE CONTINUOUS-FLOW SYNTHESIS OF 1H-INDAZOLES VIA REACTION OF o-FLUOROBENZALDEHYDES WITH tert-BUTYL CARBAZATE UNDER HIGH TEMPERATURE." *CLOCKSS Archive*, 2022. Available at:[\[Link\]](#)
- "Continuous flow heterogeneous catalytic reductive aminations under aqueous micellar conditions enabled by an oscillatory plug flow reactor." *RSC Advances*, Royal Society of Chemistry, 2021. Available at: [\[Link\]](#)

- "Benchtop ¹⁹F Nuclear Magnetic Resonance (NMR) Spectroscopy Provides Mechanistic Insight into the Biginelli Condensation toward the Chemical Synthesis of Novel Trifluorinated Dihydro- and Tetrahydropyrimidinones as Antiproliferative Agents." ACS Omega, American Chemical Society, 2023. Available at: [[Link](#)]
- To cite this document: BenchChem. [[Application Note: Advanced Continuous Flow Methodologies for Fluorinated Benzaldehyde Transformations](#)]. BenchChem, [2026]. [[Online PDF](#)]. Available at: [<https://www.benchchem.com/product/b7860237/docs#application-note-advanced-continuous-flow-methodologies-for-fluorinated-benzaldehyde-transformations>]

Disclaimer & Data Validity:

The information provided in this document is for Research Use Only (RUO) and is strictly not intended for diagnostic or therapeutic procedures. While BenchChem strives to provide accurate protocols, we make no warranties, express or implied, regarding the fitness of this product for every specific experimental setup.

Technical Support: The protocols provided are for reference purposes. Unsure if this reagent suits your experiment?

Need Industrial/Bulk Grade? [Request Custom Synthesis Quote](#)

BenchChem

Our mission is to be the trusted global source of essential and advanced chemicals, empowering scientists and researchers to drive progress in science and industry.

Contact

Address: 3281 E Guasti Rd
Ontario, CA 91761, United States
Phone: (601) 213-4426
Email: info@benchchem.com

[Contact our Ph.D. Support Team for a compatibility check](#)

