

inconsistent results in GW9662-d5 experiments

Author: BenchChem Technical Support Team. **Date:** April 2026

Compound of Interest

Compound Name: GW9662-d5

Cat. No.: B7852657

[Get Quote](#)

Technical Support Center: GW9662 Experiments

This technical support center provides troubleshooting guidance and frequently asked questions (FAQs) for researchers, scientists, and drug development professionals encountering inconsistent results in experiments involving the PPAR γ antagonist, GW9662.

Frequently Asked Questions (FAQs)

Q1: Why am I observing effects that are inconsistent with PPAR γ antagonism after GW9662 treatment?

A1: Inconsistent results with GW9662 can arise from several factors beyond its primary role as a PPAR γ antagonist. These include:

- **Off-Target Effects:** GW9662 has been shown to have unexpected off-target effects, most notably the activation of PPAR δ -mediated signaling. This can lead to outcomes that are independent of or even contrary to PPAR γ inhibition.[\[1\]](#)
- **PPAR γ -Independent Mechanisms:** Studies have demonstrated that GW9662 can inhibit the growth of certain cell lines through mechanisms that are independent of PPAR γ activation.[\[2\]](#)
[\[3\]](#) For instance, it can enhance the anti-proliferative effects of PPAR γ agonists like rosiglitazone, a counterintuitive result if acting solely as an antagonist.[\[2\]](#)[\[4\]](#)

- **Concentration-Dependent Cytotoxicity:** At higher concentrations, GW9662 can induce apoptosis and cell death in a dose-dependent manner, which may not be related to its PPAR γ antagonist activity.

Q2: What is the optimal concentration of GW9662 to use in my in vitro experiments?

A2: The optimal concentration of GW9662 is highly dependent on the cell type and the specific biological question. While it has a low nanomolar IC₅₀ for PPAR γ in cell-free assays (3.3 nM), much higher concentrations are often used in cell-based assays to achieve a functional effect.

- For antagonizing PPAR γ activity, concentrations in the low micromolar range (e.g., 1-10 μ M) are commonly reported.
- However, for observing growth inhibition in cancer cell lines, IC₅₀ values can be significantly higher (20-30 μ M).
- It is crucial to perform a dose-response curve for your specific cell line to determine the optimal concentration that provides effective PPAR γ antagonism without inducing significant cytotoxicity.

Q3: How should I prepare and store my GW9662 stock solutions?

A3: Proper preparation and storage are critical for consistent results.

- **Solubility:** GW9662 is soluble in DMSO, with stock solutions typically prepared at concentrations ranging from 26 mg/mL to 100 mM. It is insoluble in water. For cell culture, the final DMSO concentration in the media should be kept low (typically \leq 0.1%) to avoid solvent-induced artifacts.
- **Storage:** Store the powder at -20°C for long-term stability (up to 3 years). Stock solutions in DMSO can be stored at -20°C for several months or at -80°C for up to a year. It is recommended to aliquot stock solutions to avoid repeated freeze-thaw cycles.

Q4: I'm seeing an additive inhibitory effect when I co-treat cells with GW9662 and a PPAR γ agonist. Why is this happening?

A4: This paradoxical effect has been observed in several studies, particularly in breast cancer cell lines. The current understanding is that both GW9662 and some PPAR γ agonists (like rosiglitazone) can inhibit cell growth through pathways that are independent of PPAR γ activation. Therefore, when used in combination, their growth-inhibitory effects can be additive.

Troubleshooting Guide

Issue 1: Unexpected or Contradictory Cellular Phenotype

Symptoms:

- Observation of effects that are opposite to what is expected from PPAR γ inhibition (e.g., increased lipid accumulation).
- Lack of reversal of a PPAR γ agonist's effect.
- Effects are observed in cells known to have low or no PPAR γ expression.

Possible Causes & Solutions:

Potential Cause	Troubleshooting Steps
Off-target PPAR δ activation	<ol style="list-style-type: none">1. Verify PPARδ Expression: Confirm if your cell model expresses PPARδ.2. Use a PPARδ Antagonist: Co-treat with a selective PPARδ antagonist to see if the unexpected effect is reversed.3. Gene Knockdown/Knockout: Use siRNA or CRISPR to reduce PPARδ expression and re-evaluate the effect of GW9662.
PPAR γ -independent effects	<ol style="list-style-type: none">1. Confirm PPARγ Dependence: Use a structurally different PPARγ antagonist to see if the same phenotype is observed.2. PPARγ Knockdown/Knockout: Use siRNA or CRISPR to ablate PPARγ expression and determine if GW9662 still elicits the same response.
Dose-dependent cytotoxicity	<ol style="list-style-type: none">1. Perform a Viability Assay: Conduct a dose-response experiment and assess cell viability using methods like MTT or trypan blue exclusion.2. Lower the Concentration: Use the lowest effective concentration of GW9662 that still antagonizes PPARγ, as determined by a reporter assay or target gene expression analysis.

Issue 2: High Variability Between Experiments

Symptoms:

- Inconsistent results in replicate experiments performed at different times.
- Loss of compound activity over time.

Possible Causes & Solutions:

Potential Cause	Troubleshooting Steps
Improper stock solution handling	1. Prepare Fresh Aliquots: Avoid repeated freeze-thaw cycles of your stock solution by preparing single-use aliquots. 2. Use Fresh DMSO: Ensure the DMSO used for solubilization is of high quality and not moisture-laden, as this can reduce solubility.
Inconsistent cell culture conditions	1. Standardize Protocols: Ensure consistent cell passage number, seeding density, and serum concentration in your media. 2. Monitor Cell Health: Regularly check for any signs of contamination or changes in cell morphology.
Variability in compound purity	1. Source from a Reputable Vendor: Ensure the purity of the GW9662 compound. 2. Confirm Identity and Purity: If possible, verify the compound's identity and purity using techniques like HPLC or NMR.

Data Presentation

Table 1: Reported IC50 Values for GW9662

Target	Assay Type	IC50 Value	Reference
PPAR γ	Cell-free	3.3 nM	
PPAR α	Cell-free	32 nM	
PPAR δ	Cell-free	2000 nM	
MCF7 (Breast Cancer Cells)	Cell Growth Inhibition	20-30 μ M	
MDA-MB-231 (Breast Cancer Cells)	Cell Growth Inhibition	20-30 μ M	
MDA-MB-468 (Breast Cancer Cells)	Cell Growth Inhibition	20-30 μ M	

Table 2: Solubility and Storage of GW9662

Parameter	Details	Reference
Solubility	DMSO: >13.75 mg/mL to 100 mM Ethanol: 2 mg/mL to 25 mM (with warming) Water: Insoluble	
Storage (Powder)	-20°C for \geq 4 years	
Storage (Stock Solution)	-20°C for several months -80°C for up to 1 year	

Experimental Protocols

Protocol 1: General Cell-Based Assay for PPAR γ Antagonism

- Cell Seeding: Plate cells at a predetermined density in a suitable multi-well plate and allow them to adhere overnight.
- Pre-treatment with GW9662: The following day, replace the medium with fresh medium containing the desired concentration of GW9662 or vehicle control (e.g., 0.1% DMSO).

Incubate for a specified pre-treatment time (e.g., 30 minutes to 2 hours).

- Agonist Treatment: Add the PPAR γ agonist (e.g., rosiglitazone) to the wells, in the continued presence of GW9662.
- Incubation: Incubate for the desired duration to allow for changes in gene expression or cellular phenotype.
- Endpoint Analysis: Harvest cells for downstream analysis, such as qRT-PCR for PPAR γ target genes, western blotting, or a functional assay.

Visualizations

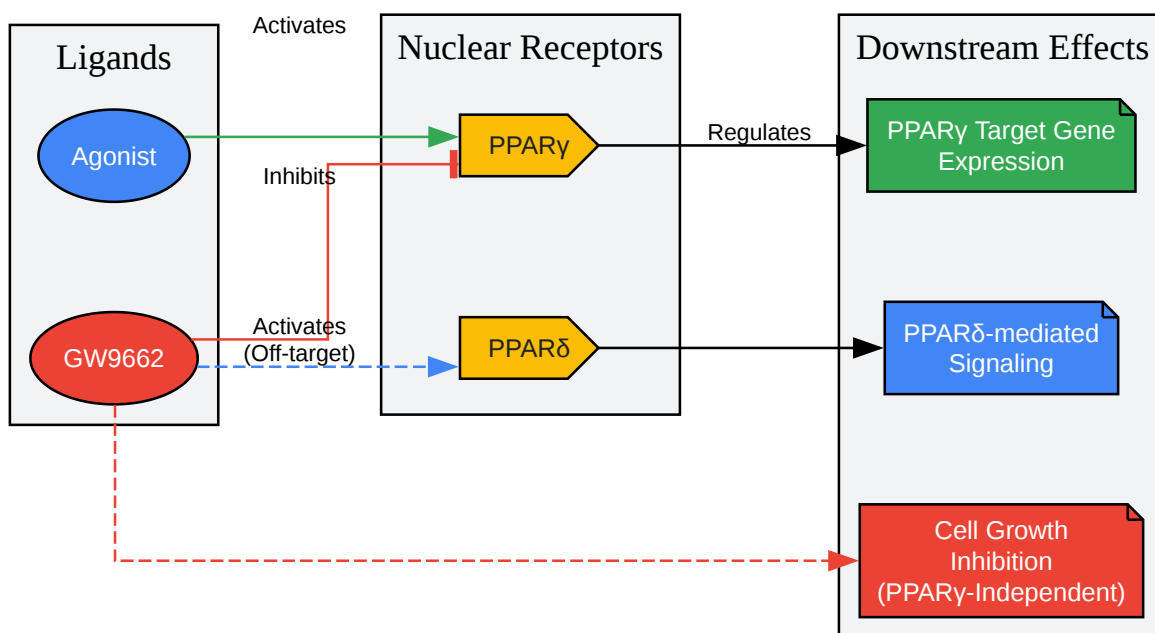

[Click to download full resolution via product page](#)

Caption: Signaling pathways affected by GW9662.

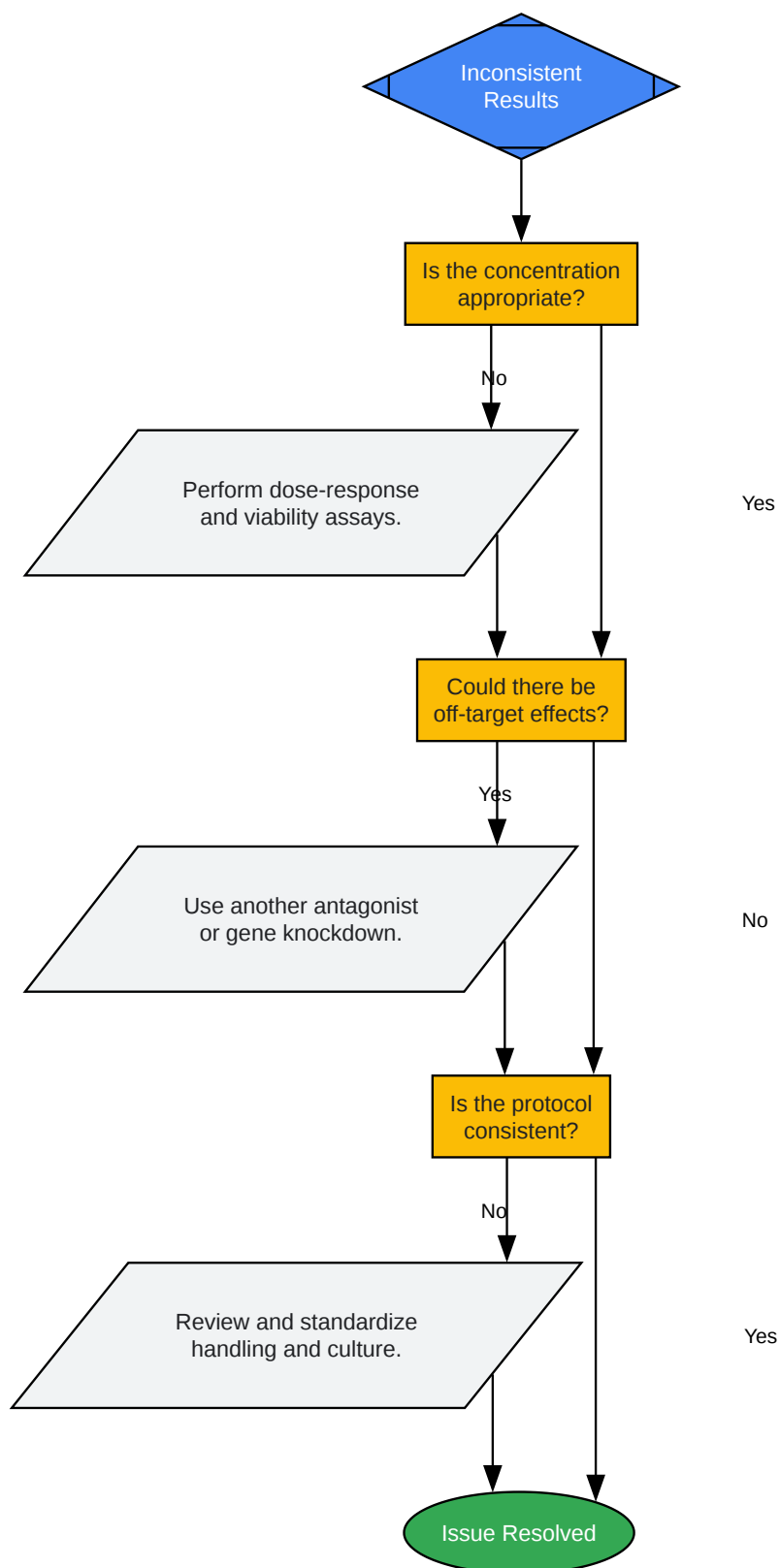

[Click to download full resolution via product page](#)

Need Custom Synthesis?

BenchChem offers custom synthesis for rare earth carbides and specific isotopic labeling.

Email: info@benchchem.com or [Request Quote Online](#).

References

- 1. The Peroxisome Proliferator-Activated Receptor (PPAR)- γ Antagonist 2-Chloro-5-Nitro-N-Phenylbenzamide (GW9662) Triggers Perilipin 2 Expression via PPAR δ and Induces Lipogenesis and Triglyceride Accumulation in Human THP-1 Macrophages - PubMed [pubmed.ncbi.nlm.nih.gov]
- 2. GW9662, a potent antagonist of PPAR γ , inhibits growth of breast tumour cells and promotes the anticancer effects of the PPAR γ agonist rosiglitazone, independently of PPAR γ activation - PMC [[pmc.ncbi.nlm.nih.gov](https://pubmed.ncbi.nlm.nih.gov)]
- 3. GW9662, a potent antagonist of PPAR γ , inhibits growth of breast tumour cells and promotes the anticancer effects of the PPAR γ agonist rosiglitazone, independently of PPAR γ activation - PubMed [pubmed.ncbi.nlm.nih.gov]
- 4. apexbt.com [apexbt.com]
- To cite this document: BenchChem. [inconsistent results in GW9662-d5 experiments]. BenchChem, [2026]. [Online PDF]. Available at: [<https://www.benchchem.com/product/b7852657/docs#inconsistent-results-in-gw9662-d5-experiments>]

Disclaimer & Data Validity:

The information provided in this document is for Research Use Only (RUO) and is strictly not intended for diagnostic or therapeutic procedures. While BenchChem strives to provide accurate protocols, we make no warranties, express or implied, regarding the fitness of this product for every specific experimental setup.

Technical Support: The protocols provided are for reference purposes. Unsure if this reagent suits your experiment?

Need Industrial/Bulk Grade? [Request Custom Synthesis Quote](#)

BenchChem

Our mission is to be the trusted global source of essential and advanced chemicals, empowering scientists and researchers to drive progress in science and industry.

Contact

Address: 3281 E Guasti Rd

Ontario, CA 91761, United States

Phone: (601) 213-4426

Email: info@benchchem.com

[Contact our Ph.D. Support Team for a compatibility check](#)