

Confirming On-Target Effects of Nutlin-3a on p53 Stabilization: A Comparative Guide

Author: BenchChem Technical Support Team. **Date:** April 2026

Compound of Interest

Compound Name: *nutlin-3A*
CAS No.: 890090-75-2
Cat. No.: B7852587

[Get Quote](#)

For Researchers, Scientists, and Drug Development Professionals

This guide provides an objective comparison of **Nutlin-3a**'s performance in stabilizing the p53 tumor suppressor protein against alternative approaches. Experimental data is presented to support the on-target effects of **Nutlin-3a**, a potent and specific inhibitor of the MDM2-p53 interaction.

Nutlin-3a operates by binding to the p53-binding pocket of MDM2, an E3 ubiquitin ligase that targets p53 for proteasomal degradation.^{[1][2]} This disruption of the MDM2-p53 interaction leads to the stabilization and accumulation of functional p53 in cells with wild-type TP53.^{[3][4]} Activated p53 can then transcriptionally regulate its target genes to induce cell cycle arrest, apoptosis, or senescence.^{[5][6]} The inactive enantiomer, Nutlin-3b, which has a significantly lower affinity for MDM2, serves as an excellent negative control to distinguish specific on-target effects from off-target activities.^{[1][7]}

The Nutlin-3a Signaling Pathway

The mechanism of action of **Nutlin-3a** is centered on the inhibition of the MDM2-p53 interaction. The following diagram illustrates this signaling pathway.

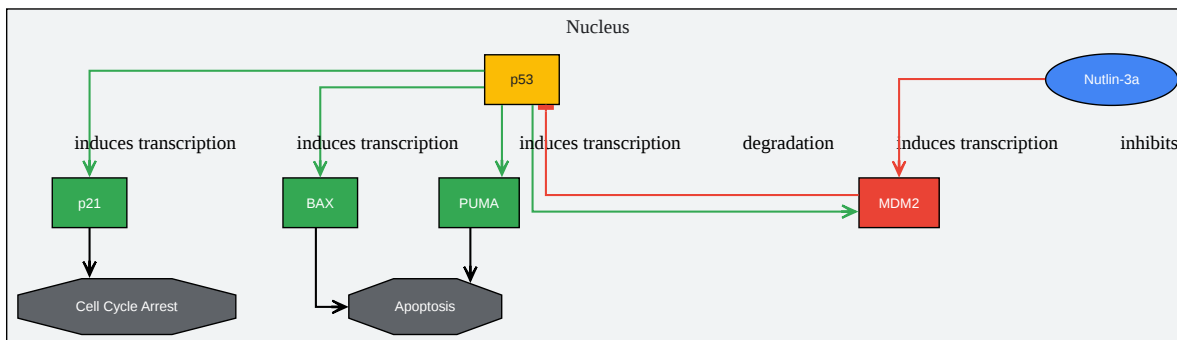

[Click to download full resolution via product page](#)

Caption: **Nutlin-3a** inhibits MDM2, leading to p53 stabilization and activation of downstream targets.

Quantitative Comparison of Nutlin-3a and Alternatives

The efficacy of **Nutlin-3a** in stabilizing p53 is demonstrated through various quantitative assays. The following tables summarize key findings from multiple studies, comparing **Nutlin-3a** to its inactive enantiomer (Nutlin-3b) and other MDM2 inhibitors.

Table 1: In Vitro Inhibition of MDM2-p53 Interaction

Compound	Target	IC50 (MDM2-p53 Interaction)	Binding Affinity (to MDM2)	Reference
Nutlin-3a	MDM2	~90 nM	High	[3][7]
Nutlin-3b	MDM2	~13.6 μM	Low (~150-200 fold lower than Nutlin-3a)	[7]
MI-219	MDM2	Ki = 5 nM	High	[3]

Table 2: Cellular Potency of Nutlin-3a in p53 Wild-Type Cells

Cell Line	Assay	Nutlin-3a IC50/EC50	Effect	Reference
HCT116 (p53+/+)	Cell Growth Inhibition	1.6 μM (Normoxia), 1.4 μM (Hypoxia)	Reduced cell growth by >75%	[8]
MCF7	Cell Growth Inhibition	8.6 μM (Normoxia), 6.7 μM (Hypoxia)	Reduced cell growth by >75%	[8]
U87MG	Cell Viability	Dose-dependent reduction	Maximum effect at 10 μM	[9][10]
U87MG	Apoptosis Induction	Dose-dependent increase	Pronounced apoptotic response	[11]
SJSA-1	p21 Induction	<10 μM	Dose-dependent increase	[12]

Experimental Workflows and Protocols

To ensure reproducibility and accurate interpretation of results, detailed experimental protocols are crucial. Below are standardized workflows and methodologies for key experiments used to

confirm the on-target effects of **Nutlin-3a**.

Experimental Workflow: Western Blot Analysis

The following diagram outlines the typical workflow for assessing protein stabilization and downstream target induction via Western blotting.



[Click to download full resolution via product page](#)

Caption: Standard workflow for Western blot analysis of p53 pathway proteins.

Detailed Experimental Protocols

1. Western Blot Analysis for p53, MDM2, and p21

- Cell Lysis: Treat cells with **Nutlin-3a** (e.g., 10 μ M) or Nutlin-3b for the desired time (e.g., 2, 4, 8, 24 hours).[11][13] Wash cells with ice-cold PBS and lyse in RIPA buffer supplemented with protease and phosphatase inhibitors.[14]
- Protein Quantification: Determine protein concentration using a BCA assay.[14][15]
- SDS-PAGE and Transfer: Separate equal amounts of protein (e.g., 40-50 μ g) on a 10% polyacrylamide gel and transfer to a PVDF or nitrocellulose membrane.[15][16]
- Antibody Incubation: Block the membrane and incubate with primary antibodies against p53, MDM2, and p21 (typically 1:1000 dilution).[16] Use an antibody against a housekeeping protein like β -actin or GAPDH for loading control.[17] Incubate with an appropriate HRP-conjugated secondary antibody (e.g., 1:3000 dilution).[16]
- Detection: Visualize protein bands using an enhanced chemiluminescence (ECL) detection system.

2. Real-Time Quantitative PCR (RT-qPCR) for p53 Target Genes

- RNA Extraction and cDNA Synthesis: After treatment, harvest cells and extract total RNA using a commercial kit. Synthesize cDNA from 1 µg of total RNA.[18]
- qPCR Reaction: Perform qPCR using target-specific primers for genes like CDKN1A (p21) and MDM2.[18][19] Use a housekeeping gene (e.g., GAPDH or ACTB) for normalization.[5][19]
- Data Analysis: Calculate the relative mRNA expression using the $\Delta\Delta C_t$ method.[20]

3. Cell Viability Assay (MTT or ATP-based)

- Cell Seeding and Treatment: Seed cells in a 96-well plate. After adherence, treat with a range of **Nutlin-3a** concentrations and controls for 48 or 72 hours.[14][21]
- Assay Performance:
 - MTT Assay: Add MTT solution and incubate. Solubilize formazan crystals with DMSO and measure absorbance.[21]
 - ATP-based Assay (e.g., CellTiter-Glo®): Add the luminescent reagent, shake to lyse cells, and measure luminescence.[14]
- Data Analysis: Normalize the readings to the vehicle-treated control and plot cell viability against the logarithm of the compound concentration to determine the IC50 value.[14]

4. Apoptosis Assay (Annexin V/PI Staining)

- Cell Treatment and Staining: Treat cells with **Nutlin-3a** for a specified time (e.g., 24 hours). [11] Harvest cells and wash with Annexin V binding buffer. Stain with FITC-conjugated Annexin V and Propidium Iodide (PI).[20]
- Flow Cytometry: Analyze the stained cells using a flow cytometer to quantify the percentage of apoptotic cells (Annexin V positive, PI negative) and late apoptotic/necrotic cells (Annexin V and PI positive).[9][20]

Conclusion

The experimental data overwhelmingly confirms the on-target effects of **Nutlin-3a** in stabilizing p53. Its high potency and specificity, particularly when compared to its inactive enantiomer Nutlin-3b, make it a valuable tool for studying the p53 pathway and a promising candidate for cancer therapy in tumors retaining wild-type p53. The protocols and comparative data presented in this guide offer a robust framework for researchers to validate and extend these findings.

Need Custom Synthesis?

BenchChem offers custom synthesis for rare earth carbides and specific isotopic labeling.

Email: info@benchchem.com or [Request Quote Online](#).

References

- [1. benchchem.com \[benchchem.com\]](#)
- [2. researchgate.net \[researchgate.net\]](#)
- [3. Pharmacologic activation of p53 by small-molecule MDM2 antagonists - PMC \[pmc.ncbi.nlm.nih.gov\]](#)
- [4. Inhibition of p53-murine double minute 2 interaction by nutlin-3A stabilizes p53 and induces cell cycle arrest and apoptosis in Hodgkin lymphoma - PubMed \[pubmed.ncbi.nlm.nih.gov\]](#)
- [5. Nutlin-3a Activates p53 to Both Down-regulate Inhibitor of Growth 2 and Up-regulate mir-34a, mir-34b, and mir-34c Expression, and Induce Senescence - PMC \[pmc.ncbi.nlm.nih.gov\]](#)
- [6. benchchem.com \[benchchem.com\]](#)
- [7. benchchem.com \[benchchem.com\]](#)
- [8. MDM2 inhibitors, nutlin-3a and navtemadelin, retain efficacy in human and mouse cancer cells cultured in hypoxia - PMC \[pmc.ncbi.nlm.nih.gov\]](#)
- [9. Activation of p53 by Nutlin-3a Induces Apoptosis and Cellular Senescence in Human Glioblastoma Multiforme | PLOS One \[journals.plos.org\]](#)
- [10. Activation of p53 by Nutlin-3a Induces Apoptosis and Cellular Senescence in Human Glioblastoma Multiforme - PMC \[pmc.ncbi.nlm.nih.gov\]](#)

- 11. Nutlin-3a Nanodisks Induce p53 Stabilization and Apoptosis in a Subset of Cultured Glioblastoma Cells - PMC [[pmc.ncbi.nlm.nih.gov](https://pubmed.ncbi.nlm.nih.gov/)]
- 12. pnas.org [pnas.org]
- 13. researchgate.net [researchgate.net]
- 14. benchchem.com [benchchem.com]
- 15. Interruption of p53-MDM2 Interaction by Nutlin-3a in Human Lymphoma Cell Models Initiates a Cell-Dependent Global Effect on Transcriptome and Proteome Level - PMC [[pmc.ncbi.nlm.nih.gov](https://pubmed.ncbi.nlm.nih.gov/)]
- 16. addi.ehu.es [addi.ehu.es]
- 17. researchgate.net [researchgate.net]
- 18. benchchem.com [benchchem.com]
- 19. Inhibition of MDM2 via Nutlin-3A: A Potential Therapeutic Approach for Pleural Mesotheliomas with MDM2-Induced Inactivation of Wild-Type P53 - PMC [[pmc.ncbi.nlm.nih.gov](https://pubmed.ncbi.nlm.nih.gov/)]
- 20. oncotarget.com [oncotarget.com]
- 21. benchchem.com [benchchem.com]
- To cite this document: BenchChem. [Confirming On-Target Effects of Nutlin-3a on p53 Stabilization: A Comparative Guide]. BenchChem, [2026]. [Online PDF]. Available at: [<https://www.benchchem.com/product/b7852587/docs#confirming-on-target-effects-of-nutlin-3a-on-p53-stabilization-a-comparative-guide>]

Disclaimer & Data Validity:

The information provided in this document is for Research Use Only (RUO) and is strictly not intended for diagnostic or therapeutic procedures. While BenchChem strives to provide accurate protocols, we make no warranties, express or implied, regarding the fitness of this product for every specific experimental setup.

Technical Support: The protocols provided are for reference purposes. Unsure if this reagent suits your experiment?

Need Industrial/Bulk Grade? [Request Custom Synthesis Quote](#)

BenchChem

Our mission is to be the trusted global source of essential and advanced chemicals, empowering scientists and researchers to drive progress in science and industry.

Contact

Address: 3281 E Guasti Rd

Ontario, CA 91761, United States

Phone: (601) 213-4426

Email: info@benchchem.com

[Contact our Ph.D. Support Team for a compatibility check](#)