

Technical Support Center: Minimizing Side Reactions in 2,6-Dichlorophenol Ethylation

Author: BenchChem Technical Support Team. **Date:** April 2026

Compound of Interest

Compound Name: 2-[2-(2,6-Dichloro-
phenoxy)ethyl]-1,3-dioxolane

Cat. No.: B7847645

[Get Quote](#)

Topic: Optimization of O-Ethylation for Sterically Hindered Phenols (2,6-DCP) Content Type: Troubleshooting Guide, FAQs, and Standard Operating Procedures (SOPs) Audience: Process Chemists, Medicinal Chemists, and R&D Scientists

Core Directive & Executive Summary

From the Desk of the Senior Application Scientist:

The ethylation of 2,6-dichlorophenol (2,6-DCP) is deceptively simple. While a standard Williamson ether synthesis appears applicable, the steric bulk of the two ortho-chlorine atoms creates a "hydrogenic canopy" effect that significantly retards nucleophilic attack. This steric hindrance alters the kinetic landscape, making the reaction susceptible to competitive side pathways—primarily elimination (E2) of the ethylating agent and oxidative coupling of the phenolate.

To achieve high conversion (>95%) and minimize impurities, you must shift the reaction control from thermodynamic to kinetic favorability for the

pathway. This guide moves beyond basic textbook protocols to address the specific mechanistic bottlenecks of 2,6-DCP.

Troubleshooting Guide & FAQs

Q1: I am observing significant off-gassing and low conversion. What is happening?

Diagnosis: You are likely witnessing the E2 elimination of your ethylating agent (Ethyl Bromide or Ethyl Iodide) driven by a base that is too strong or a temperature that is too high.

The Mechanism: The 2,6-dichloro substitution lowers the pKa of the phenol to ~6.78 (compared to 10.0 for phenol). Consequently, the 2,6-dichlorophenolate anion is formed easily but is a weak nucleophile due to electron withdrawal and steric blocking. If you use a hard, strong base like NaOH or KOH in the presence of an alkyl halide, the base may preferentially deprotonate the

-hydrogen of the ethyl group, releasing ethylene gas (the off-gassing) rather than participating in the slow

substitution.

Solution:

- **Switch Base:** Use Potassium Carbonate (). It is mild enough to deprotonate 2,6-DCP (pKa ~6.8) but poorly soluble in organic solvents, creating a "heterogeneous buffer" that minimizes E2 elimination.
- **Change Reagent:** Switch from Ethyl Bromide to Diethyl Sulfate () or Ethyl Tosylate. These reagents are less prone to elimination under mild conditions compared to alkyl halides.
- **Thermodynamic Control:** Lower the reaction temperature to 50–60°C. Elimination is entropically favored at higher temperatures.

Q2: The reaction mixture turns dark brown/black within minutes. How do I prevent this?

Diagnosis: Oxidative coupling forming quinones.

The Mechanism: Electron-rich phenolates are susceptible to oxidation. In the presence of trace oxygen and base, 2,6-DCP can oxidize to form 2,6-dichloro-1,4-benzoquinone or coupled biphenyls (diphenoquinones). These impurities are highly colored (red/brown/black) and difficult to remove.

Solution:

- Inert Atmosphere: Strictly degas all solvents and run the reaction under a positive pressure of Nitrogen or Argon.
- Reducing Agent: Add a pinch of Sodium Dithionite () or Sodium Metabisulfite to the reaction mixture to scavenge radical intermediates.

Q3: Why is the reaction stalling at 80% conversion despite excess reagent?

Diagnosis: Product Inhibition or Reagent Hydrolysis.

The Mechanism:

- Hydrolysis: If water is present (even trace amounts in the solvent or base), the ethylating agent will hydrolyze to ethanol, consuming the reagent before it reacts with the slow 2,6-DCP nucleophile.
- Kinetics: The steric bulk of the ortho-chlorines creates a high activation energy barrier. As the concentration of reagents drops, the rate slows drastically.

Solution:

- Dry Conditions: Use anhydrous solvents (DMF or Acetone dried over molecular sieves).
- Catalysis: Add 5-10 mol% Potassium Iodide (KI) (Finkelstein condition). This converts Ethyl Bromide/Chloride to the more reactive Ethyl Iodide in situ.

- Phase Transfer: Switch to a Phase Transfer Catalysis (PTC) system (see Protocol B) to pump the active phenolate into the organic phase, protecting the reagent from aqueous hydrolysis.

Mechanistic Visualization

The following diagram illustrates the competitive pathways. The goal is to maximize the green path while suppressing the red side reactions.

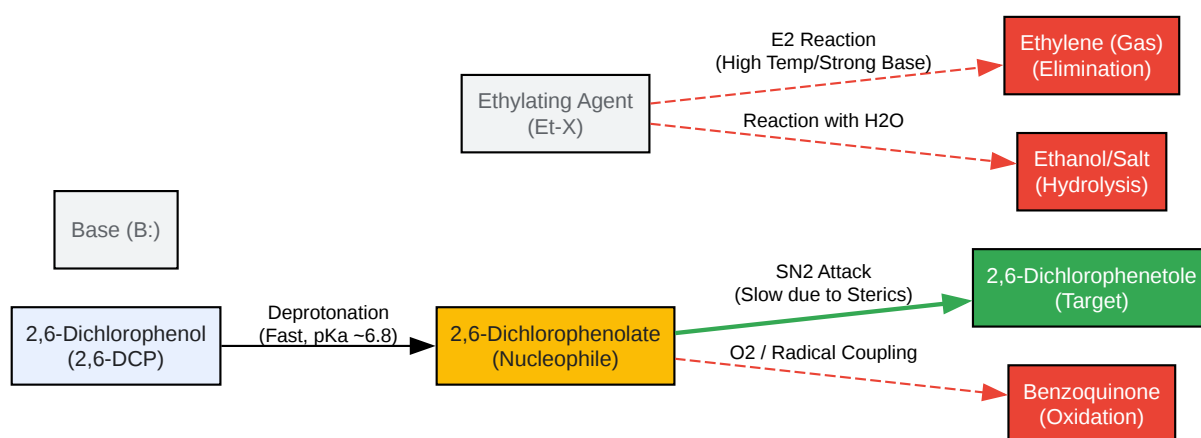

[Click to download full resolution via product page](#)

Figure 1: Competitive reaction pathways in the ethylation of 2,6-dichlorophenol. The steric bulk of the chlorines slows the desired SN₂ pathway, allowing elimination and oxidation to compete.

Experimental Protocols

Method A: The "Anhydrous Standard" (High Purity)

Recommended for small-scale (g) to medium-scale (kg) synthesis where purity is paramount.

Reagents:

- 2,6-Dichlorophenol (1.0 equiv)[1][2][3]
- Potassium Carbonate (

), anhydrous, pulverized (1.5 equiv)

- Diethyl Sulfate (1.1 equiv) OR Ethyl Iodide (1.2 equiv)
- Solvent: Acetone (reflux) or DMF (60°C)

Step-by-Step:

- Setup: Equip a 3-neck flask with a mechanical stirrer, reflux condenser, and nitrogen inlet.
- Charging: Add 2,6-DCP and anhydrous Acetone (0.5 M concentration).
- Base Addition: Add pulverized

• Stir for 15 minutes under

to form the phenolate (solution may turn slight yellow).
- Reagent Addition: Add Diethyl Sulfate dropwise over 20 minutes. Note: If using Ethyl Iodide, add it in one portion.
- Reaction: Heat to gentle reflux (56°C for Acetone). Monitor by TLC/HPLC.
 - Checkpoint: If reaction is slow after 4 hours, add 5 mol% KI.
- Workup: Filter off inorganic salts. Concentrate the filtrate. Dissolve residue in Ethyl Acetate and wash with 1M NaOH (to remove unreacted phenol) followed by Brine.
- Purification: Dry over

and concentrate. Distillation is usually not required if conversion is high; recrystallization from hexane (if solid) or vacuum distillation (if oil).

Method B: Phase Transfer Catalysis (Green/Scalable)

Recommended for large-scale production to avoid dipolar aprotic solvents.

Reagents:

- 2,6-Dichlorophenol (1.0 equiv)^{[1][2][3]}

- Toluene (Solvent)[4][5]
- 30% NaOH (aq) (2.0 equiv)
- Tetrabutylammonium Bromide (TBAB) (0.05 equiv)
- Diethyl Sulfate (1.2 equiv)

Workflow Diagram:

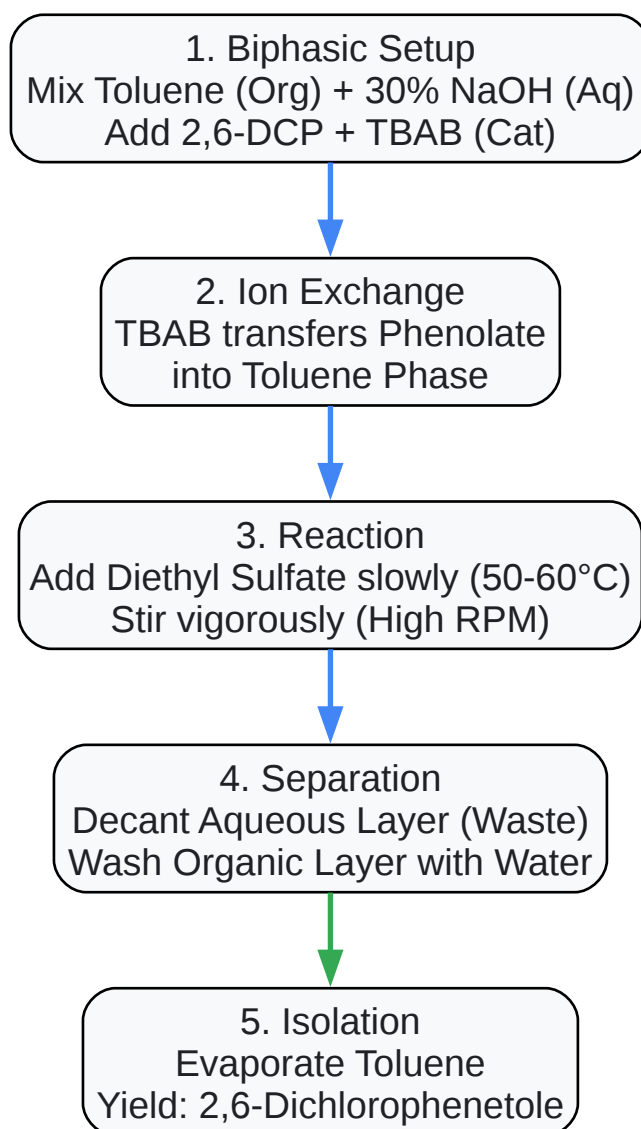

[Click to download full resolution via product page](#)

Figure 2: Phase Transfer Catalysis (PTC) workflow for scalable ethylation.

Data & Comparison

Table 1: Optimization of Reaction Parameters

Parameter	Recommended	Avoid	Reason
Base	or NaOH (w/ PTC)	NaH, t-BuOK	Strong bases promote E2 elimination (ethylene gas).
Solvent	Acetone, DMF, Toluene (PTC)	Ethanol, Methanol	Protic solvents solvate the nucleophile, reducing reactivity (suppression).
Reagent	Diethyl Sulfate ()	Ethyl Chloride	reacts faster at lower temps; EtCl requires pressure vessels.
Temp	50–65°C	>100°C	High temp increases elimination and oxidation risks.
Atmosphere	Nitrogen/Argon	Air	Oxygen causes rapid darkening (quinone formation).

References

- Organic Syntheses. (2017). Rhenium-Catalyzed ortho-Alkylation of Phenols. (Discusses steric challenges in ortho-substitution). Retrieved March 6, 2026, from [\[Link\]](#)
- Freedman, H. H., & Dubois, R. A. (1975).^[6] Phase-transfer catalysis. *Tetrahedron Letters*, 16, 3251.^[6] (Foundational PTC reference).
- PubChem. (n.d.). 2,6-Dichlorophenol Compound Summary. Retrieved March 6, 2026, from [\[Link\]](#)

Need Custom Synthesis?

BenchChem offers custom synthesis for rare earth carbides and specific isotopic labeling.

Email: info@benchchem.com or [Request Quote Online](#).

Sources

- [1. 2,6-Dichlorophenol - Wikipedia \[en.wikipedia.org\]](#)
- [2. 2,6-Dichlorophenol synthesis - chemicalbook \[chemicalbook.com\]](#)
- [3. 2,6-Dibromo-4-\[2-\(2,6-dichlorophenyl\)ethyl\]phenol | C₁₄H₁₀Br₂Cl₂O | CID 44543646 - PubChem \[pubchem.ncbi.nlm.nih.gov\]](#)
- [4. EP1321449B1 - Production method of a 2,6-dichlorophenol compound - Google Patents \[patents.google.com\]](#)
- [5. macmillan.princeton.edu \[macmillan.princeton.edu\]](#)
- [6. Phase Transfer Catalysts | Tokyo Chemical Industry Co., Ltd.\(APAC\) \[tcichemicals.com\]](#)
- To cite this document: BenchChem. [Technical Support Center: Minimizing Side Reactions in 2,6-Dichlorophenol Ethylation]. BenchChem, [2026]. [Online PDF]. Available at: [\[https://www.benchchem.com/product/b7847645/docs#technical-support-center-minimizing-side-reactions-in-2-6-dichlorophenol-ethylation\]](https://www.benchchem.com/product/b7847645/docs#technical-support-center-minimizing-side-reactions-in-2-6-dichlorophenol-ethylation)

Disclaimer & Data Validity:

The information provided in this document is for Research Use Only (RUO) and is strictly not intended for diagnostic or therapeutic procedures. While BenchChem strives to provide accurate protocols, we make no warranties, express or implied, regarding the fitness of this product for every specific experimental setup.

Technical Support: The protocols provided are for reference purposes. Unsure if this reagent suits your experiment?

Need Industrial/Bulk Grade? [Request Custom Synthesis Quote](#)

BenchChem

Our mission is to be the trusted global source of essential and advanced chemicals, empowering scientists and researchers to drive progress in science and industry.

Contact

Address: 3281 E Guasti Rd

Ontario, CA 91761, United States

Phone: (601) 213-4426

Email: info@benchchem.com

[Contact our Ph.D. Support Team for a compatibility check](#)