

Application Note: Scalable Manufacturing Processes for Fluorinated Phenyl Butanols

Author: BenchChem Technical Support Team. **Date:** April 2026

Compound of Interest

Compound Name: *1-(5-Fluoro-2-methoxyphenyl)butan-1-ol*

Cat. No.: *B7844494*

[Get Quote](#)

Abstract & Strategic Overview

Fluorinated phenyl butanols are critical structural motifs in medicinal chemistry, serving as key intermediates for antipsychotics (e.g., Haloperidol), antihistamines, and selective enzyme inhibitors. The introduction of fluorine enhances metabolic stability and lipophilicity but complicates process scalability due to the high cost of fluorinated starting materials and the safety profile of traditional organometallic reagents.

This guide addresses the transition from medicinal chemistry (milligram scale) to process chemistry (kilogram scale). We present two validated workflows:

- Continuous Flow Chemistry: For the safe, exothermic synthesis of the primary alcohol 4-(4-fluorophenyl)butan-1-ol.
- Biocatalytic Asymmetric Reduction: For the enantioselective synthesis of the secondary alcohol (R)-4-chloro-1-(4-fluorophenyl)butan-1-ol.

Route Selection Matrix

Feature	Route A: Friedel-Crafts + Flow Reduction	Route B: Biocatalytic Ketoreduction
Target Molecule	Primary Alcohols (Achiral)	Secondary Alcohols (Chiral)
Key Reagents	Fluorobenzene, Succinic Anhydride, LAH/Red-Al	KRED Enzyme, Glucose Dehydrogenase, NADP+
Scalability	High (Continuous processing)	High (Aqueous phase, low temp)
Safety Profile	Requires active heat management (Exothermic)	Green Chemistry (Benign conditions)
Atom Economy	Moderate (Aluminum waste)	Excellent (Catalytic cofactor recycling)

Protocol A: Continuous Flow Synthesis (Primary Alcohol)

Target: 4-(4-fluorophenyl)butan-1-ol Mechanism: Friedel-Crafts Acylation followed by Hydride Reduction.

Rationale for Flow Chemistry

Batch scale-up of Friedel-Crafts acylation on fluorobenzene is plagued by poor heat transfer, leading to isomer impurities (ortho/para selectivity issues) and potential thermal runaways. Continuous flow reactors offer superior surface-area-to-volume ratios, allowing precise temperature control (

C) and handling of pyrophoric reducing agents like Lithium Aluminum Hydride (LAH) in a closed system.

Flow Reactor Diagram (Graphviz)

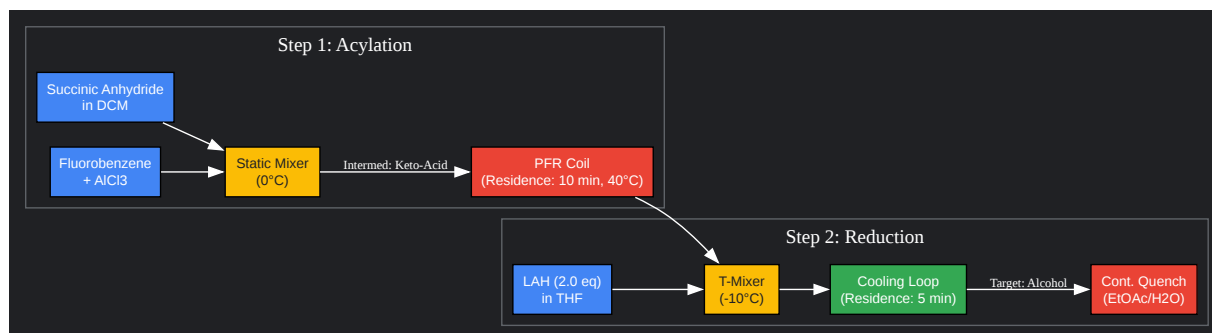

[Click to download full resolution via product page](#)

Caption: Figure 1. Continuous flow setup for sequential Friedel-Crafts acylation and reduction. PFR = Plug Flow Reactor.

Detailed Methodology

Step 1: Friedel-Crafts Acylation

- Feed Preparation:
 - Stream A: Dissolve Aluminum Chloride (, 1.2 eq) in Fluorobenzene (Solvent/Reagent). Note: is hygroscopic; handle under .
 - Stream B: Succinic Anhydride (1.0 eq) dissolved in dry Dichloromethane (DCM).
- Reaction:
 - Pump streams into a Hastelloy static mixer at 0°C to suppress initial exotherm.

- Pass through a PFA coil reactor (10 mL volume) maintained at 40°C.
- IPC (In-Process Control): Monitor consumption of anhydride via IR flow cell (carbonyl shift from 1780 to 1680).

Step 2: Reduction (Telescoped)

- Feed Preparation:
 - Stream C: 1.0 M Lithium Aluminum Hydride (LAH) in THF.
- Reaction:
 - The effluent from Step 1 is mixed directly with Stream C in a T-mixer cooled to -10°C.
 - Safety Note: This step generates gas. The system must be equipped with a back-pressure regulator (BPR) set to 7 bar to keep gas in solution and prevent slug flow.
- Quench:
 - Effluent flows into a continuous stirred tank reactor (CSTR) containing EtOAc/Rochelle salt solution to hydrolyze aluminum salts without forming a gel.

Protocol B: Biocatalytic Asymmetric Synthesis (Secondary Alcohol)

Target: (R)-4-chloro-1-(4-fluorophenyl)butan-1-ol Substrate: 4-chloro-1-(4-fluorophenyl)butan-1-one Mechanism: Stereoselective Enzymatic Ketoreduction.

Rationale for Biocatalysis

Chemical reduction of the ketone precursor typically yields a racemate, requiring wasteful chiral resolution. Biocatalysis using Ketoreductases (KREDs) offers >99% enantiomeric excess (ee)

and operates in water, eliminating the need for hazardous solvents like THF or chlorinated hydrocarbons.

Enzymatic Cycle Diagram (Graphviz)

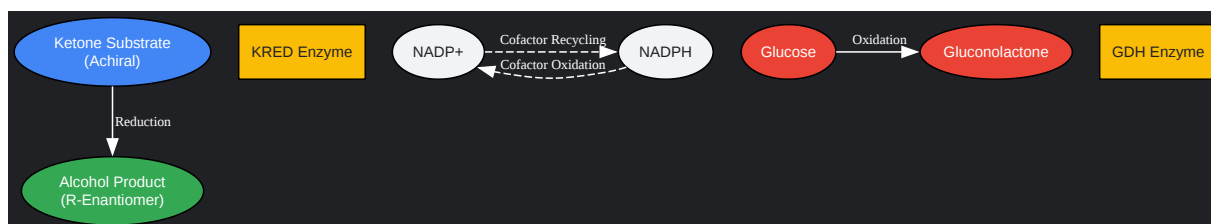

[Click to download full resolution via product page](#)

Caption: Figure 2. Coupled enzymatic cycle showing KRED-mediated reduction and GDH-mediated cofactor recycling.

Detailed Methodology

Reagents:

- Enzyme: Commercial KRED (e.g., Codexis KRED-P1 series or equivalent) screened for 'R' selectivity.
- Cofactor Recycling: Glucose Dehydrogenase (GDH-105) + Glucose + NADP⁺ (catalytic amount).
- Buffer: 100 mM Potassium Phosphate, pH 7.0.

Protocol:

- Buffer Prep: Dissolve (1.0 g/L) and Glucose (1.5 eq relative to substrate) in the phosphate buffer. Adjust pH to 7.0.
- Enzyme Loading: Add GDH (50 U/mmol substrate) and KRED (20 mg/g substrate) to the buffer.

- Substrate Addition:
 - Dissolve the fluorinated ketone in Isopropyl Alcohol (IPA) to make a 50% w/v stock.
 - Add this stock dropwise to the enzyme mixture. Final IPA concentration should not exceed 10% v/v to prevent enzyme denaturation.
- Incubation:
 - Stir at 30°C, 250 rpm.
 - pH Control: The oxidation of glucose produces gluconic acid, dropping pH. Use an autotitrator to maintain pH 7.0 with 1M NaOH.
- Workup:
 - Once conversion >99% (checked by HPLC), add diatomaceous earth (Celite) and filter to remove protein.
 - Extract aqueous phase with Methyl tert-butyl ether (MTBE).
 - Evaporate solvent to yield the chiral alcohol.

Quality Control & Analytics

Validation of the fluorinated product requires specific attention to the fluorine atom's environment.

Analytical Methods Table

Test	Method	Acceptance Criteria
Identity	NMR (376 MHz,)	Singlet at -115 ppm (approx). No peaks at -110 ppm (ortho-isomer).
Enantiomeric Purity	Chiral HPLC (Chiralcel OD-H)	> 99.0% ee (for Route B).
Residual Solvent	GC-Headspace	THF < 720 ppm, DCM < 600 ppm (ICH Q3C limits).
Water Content	Karl Fischer Titration	< 0.1% w/w (Critical for subsequent coupling steps).

Self-Validating Checkpoint

The "Fluorine Tag" Verification: In

NMR, the aromatic protons adjacent to the fluorine will appear as a distinct multiplet due to H-F coupling (

). If the Friedel-Crafts reaction (Route A) occurred at the ortho position, the symmetry of the splitting pattern changes drastically compared to the para product. Use this splitting pattern as a rapid "Go/No-Go" gate before proceeding to reduction.

References

- Friedel-Crafts Acylation & Flow Chemistry
 - Review of continuous flow Friedel-Crafts chemistry: "Development of highly efficient Friedel–Crafts alkylations with alcohols using heterogeneous catalysts under continuous-flow conditions." RSC Advances. [Link](#)
 - Acylation of Fluorobenzene: "Method for acylating fluorobenzene using Lewis acid catalysts." [1] Google Patents (CN101462931A). [Link](#)
- Biocatalysis & KREDs
 - Enzymatic Reduction of Fluorinated Ketones: "Enantioselective Reduction of 4-Fluoroacetophenone at High Substrate Concentration." ResearchGate. [Link](#)

- Biocatalytic Reduction Overview: "Biocatalytic Reduction Reactions from a Chemist's Perspective." Angewandte Chemie / NIH. [Link](#)
- Safety & Process Hazards
 - Grignard/LAH Safety: "Grignard Reaction Safety Summary." American Chemical Society (ACS). [Link](#)
 - Haloperidol Intermediate Synthesis: "Method for synthesis of haloperidol drug intermediate." [2][3][4] Google Patents (CN105503650A). [Link](#)

Need Custom Synthesis?

BenchChem offers custom synthesis for rare earth carbides and specific isotopic labeling.

Email: info@benchchem.com or [Request Quote Online](#).

Sources

- 1. pdf.benchchem.com [pdf.benchchem.com]
- 2. arborpharmchem.com [arborpharmchem.com]
- 3. Haloperidol Intermediates [ganeshremedies.com]
- 4. DE2915596A1 - METHOD FOR MANUFACTURING HALOPERIDOL - Google Patents [patents.google.com]
- To cite this document: BenchChem. [Application Note: Scalable Manufacturing Processes for Fluorinated Phenyl Butanols]. BenchChem, [2026]. [Online PDF]. Available at: [<https://www.benchchem.com/product/b7844494/docs#application-note-scalable-manufacturing-processes-for-fluorinated-phenyl-butanols>]

Disclaimer & Data Validity:

The information provided in this document is for Research Use Only (RUO) and is strictly not intended for diagnostic or therapeutic procedures. While BenchChem strives to provide accurate protocols, we make no warranties, express or implied, regarding the fitness of this product for every specific experimental setup.

Technical Support: The protocols provided are for reference purposes. Unsure if this reagent suits your experiment?

Need Industrial/Bulk Grade? [Request Custom Synthesis Quote](#)

BenchChem

Our mission is to be the trusted global source of essential and advanced chemicals, empowering scientists and researchers to drive progress in science and industry.

Contact

Address: 3281 E Guasti Rd
Ontario, CA 91761, United States
Phone: (601) 213-4426
Email: info@benchchem.com

[Contact our Ph.D. Support Team for a compatibility check](#)