

Application Notes and Protocols for the Quantification of 4-Isopropenylphenol

Author: BenchChem Technical Support Team. **Date:** April 2026

Compound of Interest

Compound Name: 4-Isopropenylphenol

CAS No.: 64054-77-9

Cat. No.: B7838621

[Get Quote](#)

For Researchers, Scientists, and Drug Development Professionals

This document provides detailed application notes and protocols for the quantitative analysis of **4-Isopropenylphenol** in various samples using High-Performance Liquid Chromatography (HPLC) with UV detection, Gas Chromatography-Mass Spectrometry (GC-MS), and Liquid Chromatography with tandem Mass Spectrometry (LC-MS/MS).

Introduction

4-Isopropenylphenol, also known as p-isopropenylphenol, is an organic compound that serves as an intermediate in the chemical industry, notably in the production of Bisphenol A (BPA).[1] Its quantification in environmental, biological, and industrial samples is crucial for quality control, exposure assessment, and toxicological studies. The analytical methods detailed herein provide sensitive and selective means for the determination of **4-isopropenylphenol** concentrations.

General Sample Preparation

Effective sample preparation is critical for accurate quantification, aiming to remove interferences and concentrate the analyte.[2][3] The choice of method depends on the sample matrix.[4]

- Solid Samples (e.g., tissues, soil):
 - Soxhlet Extraction: A common method for extracting organic compounds from solid matrices using a volatile solvent.[4]
 - Ultrasound-Assisted Extraction (UAE): Utilizes ultrasonic waves to enhance extraction efficiency, often reducing solvent consumption and time.[2]
- Liquid Samples (e.g., plasma, water):
 - Liquid-Liquid Extraction (LLE): The sample is mixed with an immiscible solvent in which **4-isopropenylphenol** has a high affinity, leading to its separation from the matrix.
 - Solid-Phase Extraction (SPE): A highly effective technique for sample cleanup and concentration.[2][5] A suitable sorbent (e.g., C18) retains the analyte, which is then eluted with a small volume of an appropriate solvent.[5][6]
 - Protein Precipitation: For biological fluids like plasma, precipitating proteins with a solvent such as acetonitrile is a common first step.[7]

A general workflow for sample preparation is depicted below.

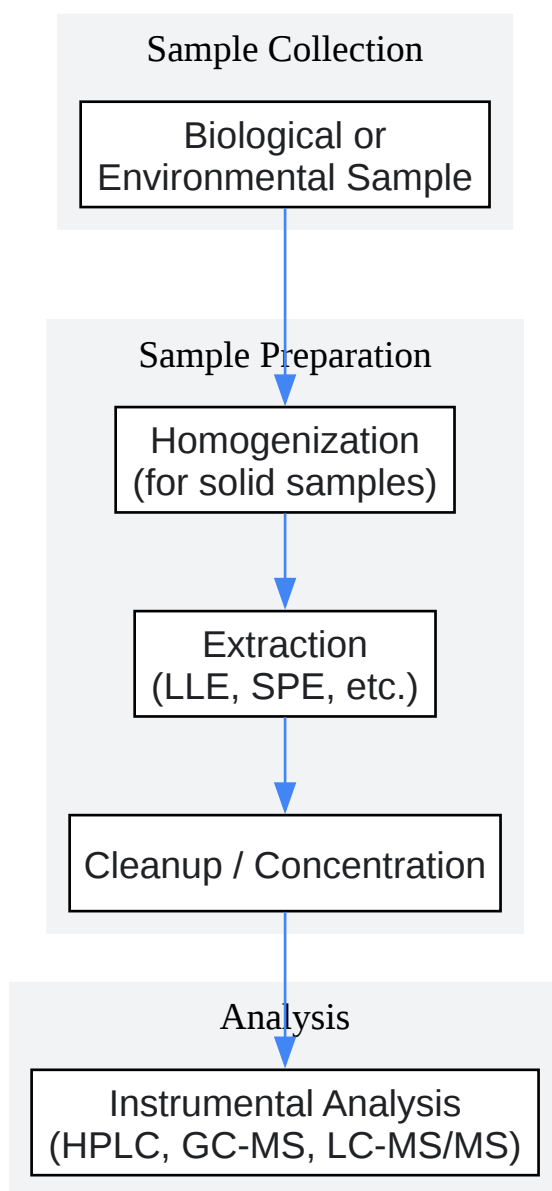

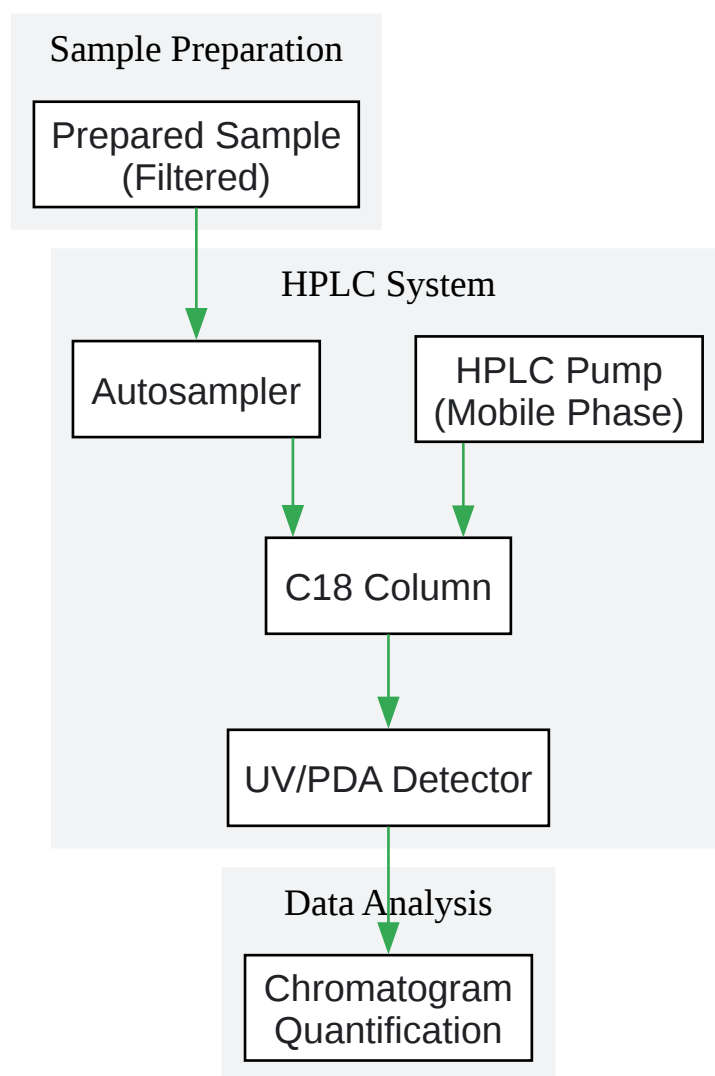

[Click to download full resolution via product page](#)

Need Custom Synthesis?

BenchChem offers custom synthesis for rare earth carbides and specific isotopic labeling.

Email: info@benchchem.com or [Request Quote Online](#).

References

- [1. 4-Isopropenylphenol - Wikipedia \[en.wikipedia.org\]](#)
- [2. benchchem.com \[benchchem.com\]](#)

- [3. Sample Preparation - SPE | Phenomenex \[phenomenex.com\]](#)
- [4. env.go.jp \[env.go.jp\]](#)
- [5. documents.thermofisher.com \[documents.thermofisher.com\]](#)
- [6. benchchem.com \[benchchem.com\]](#)
- [7. benchchem.com \[benchchem.com\]](#)
- To cite this document: BenchChem. [Application Notes and Protocols for the Quantification of 4-Isopropenylphenol]. BenchChem, [2026]. [Online PDF]. Available at: [\[https://www.benchchem.com/product/b7838621/docs#application-notes-and-protocols-for-the-quantification-of-4-isopropenylphenol\]](https://www.benchchem.com/product/b7838621/docs#application-notes-and-protocols-for-the-quantification-of-4-isopropenylphenol)

Disclaimer & Data Validity:

The information provided in this document is for Research Use Only (RUO) and is strictly not intended for diagnostic or therapeutic procedures. While BenchChem strives to provide accurate protocols, we make no warranties, express or implied, regarding the fitness of this product for every specific experimental setup.

Technical Support: The protocols provided are for reference purposes. Unsure if this reagent suits your experiment?

Need Industrial/Bulk Grade? [Request Custom Synthesis Quote](#)

BenchChem

Our mission is to be the trusted global source of essential and advanced chemicals, empowering scientists and researchers to drive progress in science and industry.

Contact

Address: 3281 E Guasti Rd

Ontario, CA 91761, United States

Phone: (601) 213-4426

Email: info@benchchem.com

Contact our Ph.D. Support Team for a compatibility check