

# An In-depth Technical Guide to Potassium Ethanolate: Chemical Properties and Structure

**Author:** BenchChem Technical Support Team. **Date:** April 2026

## Compound of Interest

Compound Name: *potassium;ethanolate*

Cat. No.: *B7822025*

[Get Quote](#)

For Researchers, Scientists, and Drug Development Professionals

## Introduction

Potassium ethanolate, also known as potassium ethoxide, is a powerful organic base with the chemical formula  $C_2H_5KO$ .<sup>[1][2]</sup> It is a valuable reagent in organic synthesis, prized for its ability to facilitate a wide range of reactions, including deprotonations, eliminations, and condensations. This technical guide provides a comprehensive overview of the chemical properties and structural features of potassium ethanolate, tailored for professionals in research and drug development.

## Chemical Properties

Potassium ethanolate is a white or yellowish powder that is highly reactive and hygroscopic.<sup>[2]</sup> <sup>[3]</sup> Its strong basicity stems from the ethoxide anion ( $C_2H_5O^-$ ), the conjugate base of ethanol. This inherent reactivity necessitates careful handling and storage under inert, anhydrous conditions to prevent decomposition.<sup>[3]</sup>

## Physicochemical Data

A summary of the key physicochemical properties of potassium ethanolate is presented in the table below for easy reference.

Property	Value	References
Chemical Formula	C <sub>2</sub> H <sub>5</sub> KO	[2][4]
Molar Mass	84.16 g/mol	
Appearance	White to yellowish powder	[2][3]
Density	0.894 g/mL at 25 °C	
Melting Point	250 °C (decomposes)	[5]
pKa of Conjugate Acid (Ethanol)	~16	
Solubility	Reacts violently with water. Soluble in ethanol.	[3]

## Reactivity and Handling

Potassium ethanolate is a potent base and nucleophile. Its key reactive characteristics include:

- **Strong Basicity:** It readily deprotonates a wide variety of organic compounds, including alcohols, terminal alkynes, and carbon acids like malonic esters. This property is central to its use in condensation reactions and alkylations.
- **Hydrolysis:** It reacts vigorously with water to form potassium hydroxide and ethanol. This highlights the critical need for anhydrous conditions during its use and storage.[2]
- **Reactivity with Acids:** As a strong base, it will react exothermically with acids.
- **Air Sensitivity:** Prolonged exposure to air can lead to decomposition through reaction with atmospheric moisture and carbon dioxide.

Due to its hazardous nature, potassium ethanolate should be handled with appropriate personal protective equipment, including gloves and safety glasses, in a well-ventilated area or under an inert atmosphere.

## Chemical Structure

The structure of potassium ethanolate is characterized by an ionic bond between the potassium cation ( $K^+$ ) and the ethoxide anion ( $C_2H_5O^-$ ). In the solid state, it is expected to form a crystalline lattice, although detailed crystallographic data for potassium ethanolate is not as readily available as for its sodium analogue.[6] Computational studies and comparisons with related alkali metal alkoxides suggest a polymeric structure in the solid state, with potassium ions coordinated to multiple ethoxide anions.

In solution, the nature of the species present is dependent on the solvent. In polar, protic solvents like ethanol, it exists as a mixture of solvent-separated ion pairs and free ions. The degree of ion pairing can influence its reactivity in organic reactions.

## Experimental Protocols

Detailed experimental procedures are crucial for the safe and effective use of potassium ethanolate. Below are representative protocols for its synthesis and characterization.

## Synthesis of Potassium Ethanolate

Method 1: From Potassium Metal and Ethanol

This is a common laboratory-scale synthesis.

Materials:

- Potassium metal
- Anhydrous ethanol
- An inert atmosphere (e.g., nitrogen or argon)

Procedure:

- Under a strictly inert and anhydrous atmosphere, carefully add small, freshly cut pieces of potassium metal to a flask containing anhydrous ethanol. The reaction is exothermic and produces hydrogen gas, so proper ventilation and caution are essential.[7]

- The reaction mixture is stirred until all the potassium metal has dissolved.
- The resulting solution of potassium ethanolate in ethanol can be used directly or the solvent can be removed under reduced pressure to yield solid potassium ethanolate.

#### Method 2: From Potassium Hydroxide and Ethanol via Azeotropic Distillation

This method avoids the use of hazardous potassium metal.

Materials:

- Potassium hydroxide (KOH)
- Anhydrous ethanol
- A suitable azeotroping agent (e.g., benzene or toluene)
- Dean-Stark apparatus

Procedure:

- In a round-bottom flask equipped with a Dean-Stark trap and a condenser, combine potassium hydroxide and anhydrous ethanol.
- Add the azeotroping agent to the flask.
- Heat the mixture to reflux. The water formed from the reaction between KOH and ethanol will be removed as an azeotrope with the solvent, collecting in the Dean-Stark trap.<sup>[1]</sup>
- Continue the reaction until no more water is collected.
- After cooling, the solution of potassium ethanolate in ethanol can be used, or the solvent can be removed to obtain the solid product.

## Characterization

Nuclear Magnetic Resonance (NMR) Spectroscopy

- $^1\text{H}$  NMR: The proton NMR spectrum of potassium ethanolate in a deuterated solvent like ethanol- $\text{d}_6$  would show characteristic signals for the ethyl group. The methylene protons ( $-\text{CH}_2-$ ) would appear as a quartet, and the methyl protons ( $-\text{CH}_3$ ) as a triplet. The chemical shifts would be influenced by the electronegative oxygen atom.
- $^{13}\text{C}$  NMR: The carbon NMR spectrum would display two distinct signals corresponding to the two carbon atoms of the ethoxide anion. The carbon atom bonded to the oxygen will have a larger chemical shift (downfield) compared to the methyl carbon.

### Infrared (IR) Spectroscopy

The FT-IR spectrum of potassium ethanolate will exhibit characteristic vibrational modes. Key absorptions would include:

- C-H stretching vibrations of the alkyl chain.
- C-O stretching vibration, which is a strong and characteristic band for alkoxides.
- C-C stretching and various bending vibrations.

## Applications in Research and Drug Development

Potassium ethanolate is a versatile reagent with numerous applications in organic synthesis, making it a valuable tool for drug development professionals.

- **Condensation Reactions:** It is widely used to promote Claisen condensations, Dieckmann condensations, and other related reactions for the formation of carbon-carbon bonds, which are fundamental in the synthesis of complex molecular scaffolds.
- **Williamson Ether Synthesis:** Potassium ethanolate can be used to deprotonate alcohols, forming alkoxides that can then react with alkyl halides to form ethers.
- **Malonic Ester and Acetoacetic Ester Syntheses:** It serves as the base of choice for creating the enolates of malonic and acetoacetic esters, which are key intermediates in the synthesis of a variety of carboxylic acids and ketones.
- **Elimination Reactions:** As a strong, non-hindered base, it can be used to promote E2 elimination reactions to form alkenes.

## Signaling Pathways and Logical Relationships

The following diagrams illustrate key concepts related to potassium ethanolate.

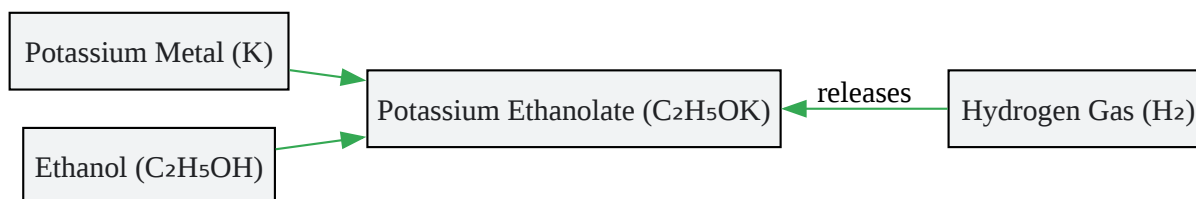

[Click to download full resolution via product page](#)

Caption: Synthesis of Potassium Ethanolate from Potassium Metal.

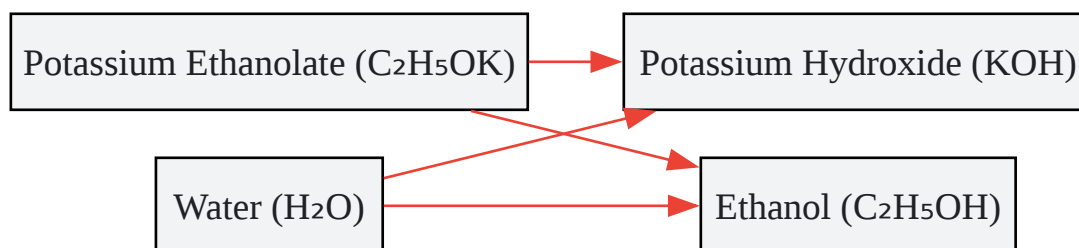

[Click to download full resolution via product page](#)

Caption: Hydrolysis of Potassium Ethanolate.

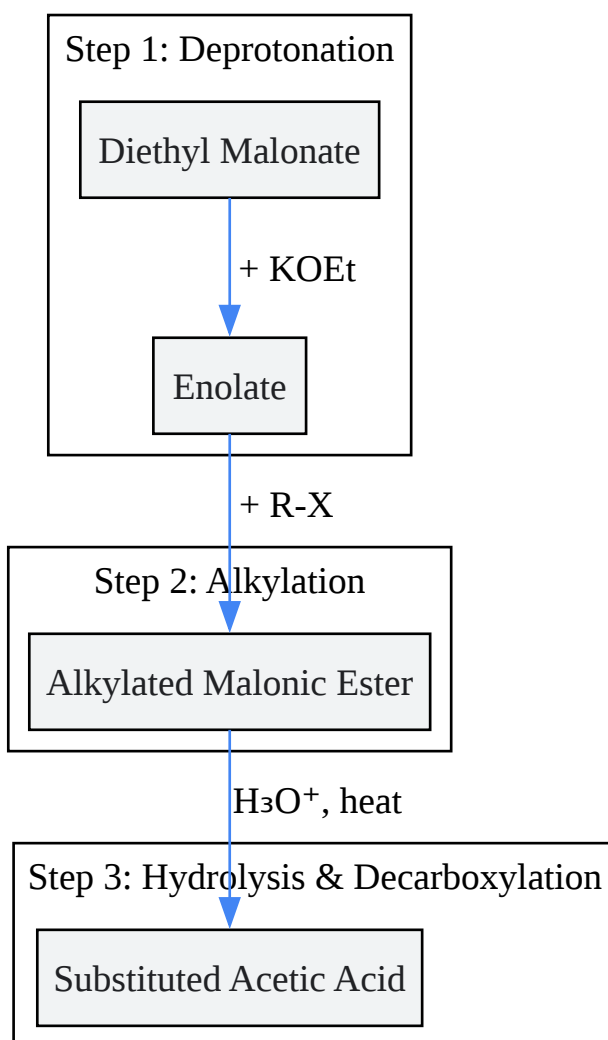

[Click to download full resolution via product page](#)

Caption: Role of Potassium Ethanolate in Malonic Ester Synthesis.

## Conclusion

Potassium ethanolate is a cornerstone reagent in organic chemistry with significant utility in research and development, particularly in the pharmaceutical industry. Its strong basicity and nucleophilicity enable a wide array of synthetic transformations. A thorough understanding of its chemical properties, structure, and safe handling procedures is paramount for its effective and responsible use in the laboratory. This guide has provided a detailed overview to assist researchers and scientists in harnessing the full potential of this versatile compound.

**Need Custom Synthesis?**

BenchChem offers custom synthesis for rare earth carbides and specific isotopic labeling.

Email: [info@benchchem.com](mailto:info@benchchem.com) or [Request Quote Online](#).

## References

- [1. Sciencemadness Discussion Board - Potassium ethoxide - Powered by XMB 1.9.11 \[sciencemadness.org\]](#)
- [2. Potassium ethoxide - Wikipedia \[en.wikipedia.org\]](#)
- [3. CAS 917-58-8: Potassium ethoxide | CymitQuimica \[cymitquimica.com\]](#)
- [4. Sciencemadness Discussion Board - Synthesis of anhydrous potassium alkoxides? - Powered by XMB 1.9.11 \[sciencemadness.org\]](#)
- [5. Gas electron diffraction - Wikipedia \[en.wikipedia.org\]](#)
- [6. journals.iucr.org \[journals.iucr.org\]](#)
- [7. chemistry.stackexchange.com \[chemistry.stackexchange.com\]](#)
- To cite this document: BenchChem. [An In-depth Technical Guide to Potassium Ethanolate: Chemical Properties and Structure]. BenchChem, [2026]. [Online PDF]. Available at: [\[https://www.benchchem.com/product/b7822025/docs#an-in-depth-technical-guide-to-potassium-ethanolate-chemical-properties-and-structure\]](https://www.benchchem.com/product/b7822025/docs#an-in-depth-technical-guide-to-potassium-ethanolate-chemical-properties-and-structure)

---

### Disclaimer & Data Validity:

The information provided in this document is for Research Use Only (RUO) and is strictly not intended for diagnostic or therapeutic procedures. While BenchChem strives to provide accurate protocols, we make no warranties, express or implied, regarding the fitness of this product for every specific experimental setup.

**Technical Support:** The protocols provided are for reference purposes. Unsure if this reagent suits your experiment?

**Need Industrial/Bulk Grade?** [Request Custom Synthesis Quote](#)

# BenchChem

Our mission is to be the trusted global source of essential and advanced chemicals, empowering scientists and researchers to drive progress in science and industry.

## Contact

Address: 3281 E Guasti Rd

Ontario, CA 91761, United States

Phone: (601) 213-4426

Email: [info@benchchem.com](mailto:info@benchchem.com)

[Contact our Ph.D. Support Team for a compatibility check](#)