

# Application Note: Stereoselective High-Throughput Screening for Allocystathionine Levels

**Author:** BenchChem Technical Support Team. **Date:** May 2026

## Compound of Interest

Compound Name: *Allocystathionine*

CAS No.: 61949-06-2

Cat. No.: B7821828

[Get Quote](#)

Methodology: Chiral LC-MS/MS with Automated Sample Preparation Target Analyte:

**Allocystathionine** (Diastereomeric purity & quantification) Application Area: Metabolic Flux Analysis, CBS Inhibitor/Activator Screening, Biomarker Discovery[1][2][3]

## Executive Summary & Scientific Rationale

**Allocystathionine** (specifically the allo- diastereomers of cystathionine) represents a subtle but critical marker in sulfur metabolism.[1][2] While L-Cystathionine is the canonical intermediate of the mammalian transsulfuration pathway (catalyzed by CBS), the presence of **allocystathionine** often indicates:

- Non-enzymatic racemization (aging/oxidative stress markers).[1][2]
- Microbial metabolism (specific bacterial lyases produce distinct stereoisomers).
- Synthetic impurity in reference standards used for HTS campaigns.

Standard reverse-phase (C18) LC-MS/MS methods often fail to resolve L-cystathionine from **allocystathionine** due to identical mass-to-charge ratios (

223.[1][2]1) and similar hydrophobicity.[1][2] This co-elution compromises data integrity in High-Throughput Screening (HTS), leading to false positives in enzyme assays or inaccurate quantification in clinical samples.[1][2]

This guide details a Stereoselective HTS Protocol utilizing zwitterionic chiral stationary phases coupled with tandem mass spectrometry. This system guarantees the resolution of **allocystathionine** from its L-isomer within a <4-minute run time, enabling the processing of 384-well plates with high specificity.[2]

## Biological Context: The Transsulfuration Pathway[4][5][6][7][8][9]

Understanding the stereochemical origin is vital.[1] The mammalian enzyme Cystathionine

-Synthase (CBS) is stereospecific, condensing L-Homocysteine and L-Serine to form L-Cystathionine.[1][2] Deviations from this (formation of **allocystathionine**) suggest alternative pathways or chemical degradation.[1][2]

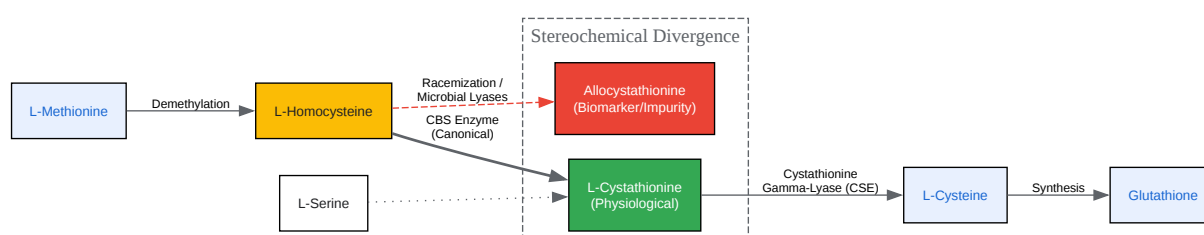

[Click to download full resolution via product page](#)

Figure 1: The Transsulfuration Pathway highlighting the stereochemical divergence between physiological L-Cystathionine and the target analyte **Allocystathionine**.[1][2]

## Methodological Framework

### The Separation Challenge

**Allocystathionine** and L-Cystathionine are diastereomers (2 stereocenters).[1][2]

- Mass (M+H)<sup>+</sup>: 223.07 Da (Identical)[1][2]
- Fragmentation: 223 -> 134, 223 -> 88 (Identical MRM transitions)
- Solution: Separation must occur chromatographically before MS detection.

### Selected HTS Platform

- Chromatography: Zwitterionic Chiral Stationary Phase (e.g., Chiralpak ZWIX(+) or equivalent).[1][2] These columns separate amino acids based on stereochemistry without pre-column derivatization, which is crucial for maintaining HTS speed.[1]
- Detection: Triple Quadrupole MS (QqQ) in MRM mode.
- Format: 96-well or 384-well plate format.

## Detailed Protocol

### Reagents & Standards

- Primary Standard: DL-**Allocystathionine** (custom synthesis or high-purity vendor).[1][2]
- Interference Check: L-Cystathionine (Sigma C7505 or equivalent).[1][2]
- Internal Standard (IS): L-Cystathionine-d4 (isotopic label).[1][2]
- Mobile Phase A: Methanol/Acetonitrile/Water (49:49:[1]2) + 50mM Formic Acid + 25mM Ammonium Formate.[1][2]
- Mobile Phase B: Methanol + 50mM Formic Acid.[1][2]

### Sample Preparation (Protein Precipitation)

Rationale: Direct injection of biological fluids clogs columns.[1][2] A "Crash & Shoot" method is optimized here for speed.

- Aliquot: Transfer 20  $\mu$ L of sample (plasma, cell lysate, or enzymatic reaction mix) into a 96-well deep-well plate.
- Spike IS: Add 10  $\mu$ L of Internal Standard solution (10  $\mu$ M Cystathionine-d4).
- Precipitate: Add 150  $\mu$ L of ice-cold Acetonitrile containing 1% Formic Acid.
- Agitate: Seal plate and vortex at 1200 rpm for 2 minutes.
- Clarify: Centrifuge at 4,000 x g for 10 minutes at 4°C.
- Transfer: Transfer 100  $\mu$ L of supernatant to a fresh analytical plate.

## LC-MS/MS Parameters[1][2]

Chromatographic Conditions:

- Column: Chiralpak ZWIX(+), 3  $\mu$ m, 3.0 x 150 mm (Daicel).[1]
- Flow Rate: 0.8 mL/min (High flow allowed by double-zwitterionic mechanism).[1][2]
- Column Temp: 30°C.
- Injection Vol: 2  $\mu$ L.

Gradient Profile:

Time (min)	% Mobile Phase B	Rationale
0.0	0	Initial equilibration
0.5	0	Load sample
2.5	40	Rapid elution of isomers
2.6	100	Wash column
3.0	100	Hold wash
3.1	0	Re-equilibrate

| 4.0 | 0 | Ready for next injection [\[1\]](#)[\[2\]](#)

Mass Spectrometry (MRM Transitions):

- Ionization: ESI Positive mode.
- Source Temp: 500°C (Amino acids require high desolvation heat).[\[1\]](#)[\[2\]](#)

Analyte	Precursor (m/z)	Product (m/z)	Collision Energy (V)	Dwell (ms)
Allocystathionine	223.1	134.1	18	20
Allocystathionine (Qual)	223.1	88.1	24	20
L-Cystathionine	223.1	134.1	18	20
Cystathionine-d4 (IS)	227.1	138.1	18	20

## Experimental Workflow Diagram

This workflow illustrates the "Loop" of HTS, ensuring data from the mass spec feeds back into the screening logic (e.g., hit selection).

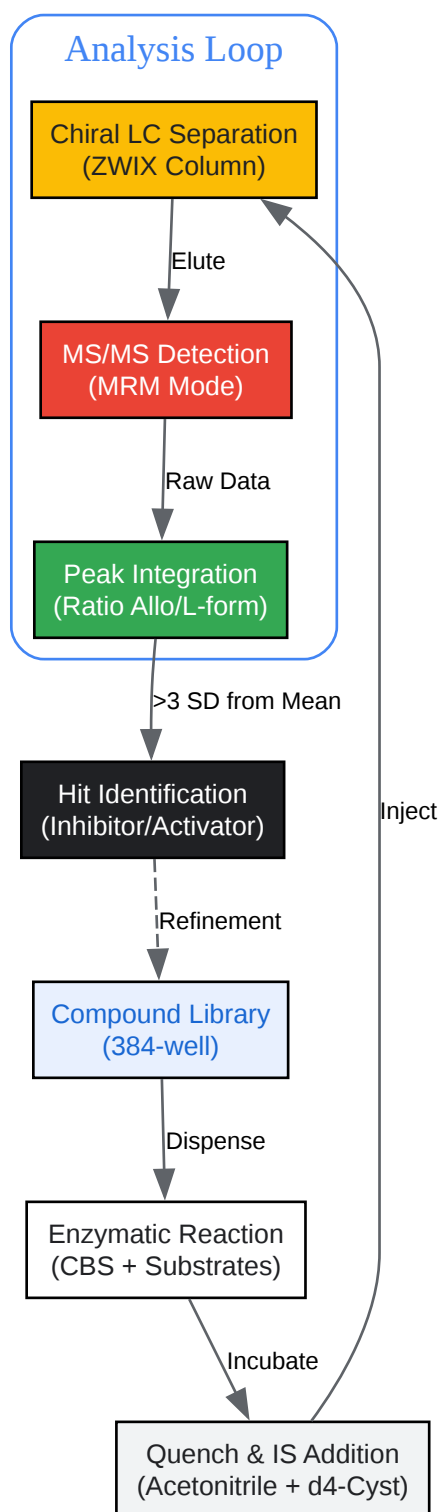

[Click to download full resolution via product page](#)

Figure 2: High-Throughput Screening Workflow for **Allocystathionine** quantification.

## Validation & Quality Control

To ensure the protocol is "self-validating" (Trustworthiness), implement the following criteria for every plate run:

### Resolution Factor ( )

The critical metric is the separation between L-Cystathionine and **Allocystathionine**.<sup>[1][2]</sup>

<sup>[1][2]</sup>

- Requirement:

(Baseline resolution) is mandatory.<sup>[1][2]</sup> If

, the column requires regeneration or the flow rate must be reduced.

### Linearity and Sensitivity<sup>[1]</sup>

- Linear Range: 50 nM – 50 µM.<sup>[1][2]</sup>
- LLOQ (Lower Limit of Quantification): 20 nM (S/N > 10).<sup>[1]</sup>
- Precision (CV%): <15% across the plate.

### Matrix Effect Monitoring

Monitor the Internal Standard (IS) Area across the plate.<sup>[1]</sup>

- Acceptance: IS area should not deviate >20% from the mean. A systematic drop indicates ion suppression from the biological matrix (e.g., phospholipids).<sup>[1]</sup>

## Troubleshooting Guide

Issue	Probable Cause	Corrective Action
Co-elution of Isomers	Column degradation or wrong pH	Verify Mobile Phase A pH is exactly 3.0-4.0 (ammonium formate buffer). Check column age (>1000 injections).[1][2]
High Backpressure	Protein precipitation incomplete	Increase centrifugation speed or use a 0.2 µm filter plate.
Signal Drift	Source contamination	Clean ESI cone/capillary.[1][2] Divert flow to waste for the first 0.5 min of gradient.
Ghost Peaks	Carryover	Increase wash step (100% B) duration or add a needle wash (50% MeOH).

## References

- Proteopedia. (2025).[1][2][4] Cystathionine beta-synthase Structure and Function. Retrieved from [1][2]
- PubChem. (2025).[1][2] Cystathionine Compound Summary (CID 834).[1][2] National Library of Medicine.[2] Retrieved from [1][2]
- Kozich, V., et al. (2014).[1][2][5] Simultaneous determination of cystathionine, total homocysteine, and methionine in dried blood spots by liquid chromatography/tandem mass spectrometry.[5] Clinica Chimica Acta.[1][2] Retrieved from
- Majtan, T., et al. (2025).[1][2] New homocysteine consumption assay for high-throughput screening of human cystathionine-β-synthase.[1][2][6] Hibernation.nl.[1][2] Retrieved from [1][2]
- RCSB PDB. (2025). Structure of Human Cystathionine Beta-Synthase.[1][2][4][7] Protein Data Bank.[1][2] Retrieved from [1][2]

**Need Custom Synthesis?**

BenchChem offers custom synthesis for rare earth carbides and specific isotopic labeling.

Email: [info@benchchem.com](mailto:info@benchchem.com) or [Request Quote Online](#).

## Sources

- [1. Cystathionine - Wikipedia \[en.wikipedia.org\]](#)
- [2. Cystathionine | C7H14N2O4S | CID 834 - PubChem \[pubchem.ncbi.nlm.nih.gov\]](#)
- [3. hibernation.nl \[hibernation.nl\]](#)
- [4. Cystathionine  \$\beta\$ -synthase - Proteopedia, life in 3D \[proteopedia.org\]](#)
- [5. Simultaneous determination of cystathionine, total homocysteine, and methionine in dried blood spots by liquid chromatography/tandem mass spectrometry and its utility for the management of patients with homocystinuria - PubMed \[pubmed.ncbi.nlm.nih.gov\]](#)
- [6. New homocysteine consumption assay for high-throughput screening of human cystathionine- \$\beta\$ -synthase - PubMed \[pubmed.ncbi.nlm.nih.gov\]](#)
- [7. rcsb.org \[rcsb.org\]](#)
- To cite this document: BenchChem. [Application Note: Stereoselective High-Throughput Screening for Allocystathionine Levels]. BenchChem, [2026]. [Online PDF]. Available at: [<https://www.benchchem.com/product/b7821828/docs#application-note-stereoselective-high-throughput-screening-for-allocystathionine-levels>]

---

**Disclaimer & Data Validity:**

The information provided in this document is for Research Use Only (RUO) and is strictly not intended for diagnostic or therapeutic procedures. While BenchChem strives to provide accurate protocols, we make no warranties, express or implied, regarding the fitness of this product for every specific experimental setup.

**Technical Support:** The protocols provided are for reference purposes. Unsure if this reagent suits your experiment?

**Need Industrial/Bulk Grade?** [Request Custom Synthesis Quote](#)

# BenchChem

Our mission is to be the trusted global source of essential and advanced chemicals, empowering scientists and researchers to drive progress in science and industry.

## Contact

Address: 3281 E Guasti Rd  
Ontario, CA 91761, United States  
Phone: (601) 213-4426  
Email: [info@benchchem.com](mailto:info@benchchem.com)

[Contact our Ph.D. Support Team for a compatibility check](#)