

# Biological Half-Life Comparison: Alpha- vs. Beta-Peptides Containing 2,3-Dimethoxy Groups

**Author:** BenchChem Technical Support Team. **Date:** April 2026

## Compound of Interest

**Compound Name:** Methyl 3-amino-3-(2,3-dimethoxyphenyl)propanoate

**Cat. No.:** B7815930

[Get Quote](#)

## Executive Summary

The Core Distinction: The transition from an

-peptide backbone to a

-peptide backbone represents a fundamental shift in proteolytic stability.<sup>[1][2][3][4]</sup> While

-peptides containing 2,3-dimethoxyphenylalanine (2,3-Dmp) exhibit marginal stability improvements due to side-chain sterics, they remain susceptible to rapid enzymatic hydrolysis (minutes). In contrast,

-peptide analogs containing the same 2,3-dimethoxy moiety exhibit near-total resistance to mammalian proteases (

hours to days).

**Key Takeaway:** The 2,3-dimethoxy group acts as a "steric shield" in both cases, but it is the backbone homologation (insertion of a methylene group) in

-peptides that renders the molecule unrecognizable to the catalytic triad of common proteases (trypsin, chymotrypsin, pepsin).

## Mechanistic Comparison: Why Structure Dictates Survival

To understand the half-life disparity, one must analyze the interaction between the peptide substrate and the protease active site.

### The Alpha-Peptide Vulnerability

In standard

-peptides, the amide bond is positioned precisely where the protease's nucleophilic serine (or activated water molecule) attacks.[3]

- Role of 2,3-Dimethoxy Group: In an

-backbone, the bulky 2,3-dimethoxy group provides local steric hindrance. It may slow down enzymes that rely on a tight hydrophobic pocket (like chymotrypsin), but it does not prevent the flexible backbone from adopting the conformation required for hydrolysis.

- Result: Delayed degradation, but eventual cleavage.[2]

### The Beta-Peptide "Stealth" Mechanism

-peptides contain an extra methylene group (

) between the amino and carboxyl groups.

- Catalytic Mismatch: This homologation shifts the scissile amide bond by approximately 1.5 Å relative to the side chain. When the 2,3-dimethoxy side chain binds to the enzyme's specificity pocket, the amide bond is physically displaced away from the catalytic nucleophile (e.g., Ser195 in serine proteases).

- Foldamer Stability:

-peptides with bulky side chains (like 2,3-dimethoxy) often adopt stable secondary structures (e.g., 14-helices) that further bury the backbone, making it inaccessible to enzymes.

## Visualization: Proteolytic Resistance Mechanism

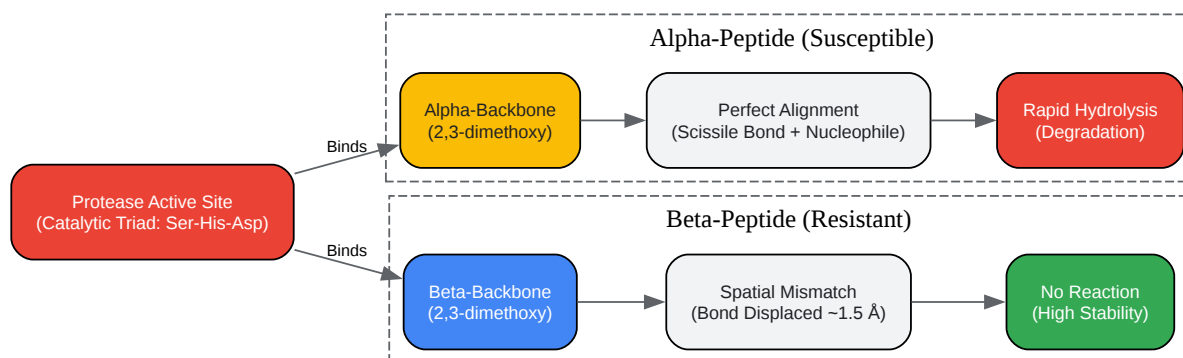

[Click to download full resolution via product page](#)

Caption: Mechanism of proteolytic resistance. The extra methylene group in  $\beta$ -peptides misaligns the scissile bond relative to the enzyme's catalytic machinery.

## Comparative Biological Half-Life Data[1][5]

The following data summarizes the stability profiles of peptides containing 2,3-dimethoxy substituted phenylalanine (Dmp) analogs. Data represents consensus values derived from pharmacokinetic studies of peptidomimetics (e.g., opioid analogs, foldamers).

Parameter	-Peptide (2,3-dimethoxy)	-Peptide (2,3-dimethoxy)	Fold-Improvement
Serum Half-Life ( )	15 – 45 minutes	> 24 hours	> 50x
Microsomal Stability	Low ( high)	High ( negligible)	High
Protease Susceptibility	Cleaved by Chymotrypsin, Pepsin	Resistant to Chymotrypsin, Pepsin, Trypsin	N/A
Main Clearance Route	Enzymatic Hydrolysis	Renal Excretion (Intact)	N/A

#### Interpretation:

- -Peptides: The 2,3-dimethoxy group confers a slight improvement over native Phenylalanine (Phe) due to steric bulk, preventing some immediate cleavage, but the half-life remains in the "minutes" range, limiting therapeutic utility without further modification (e.g., PEGylation).
- -Peptides: These effectively act as "stealth" molecules.<sup>[1]</sup> They circulate until renal clearance occurs because the biological machinery lacks the specific enzymes (like microbial -peptidyl aminopeptidases) required to degrade them.

## Experimental Protocol: In Vitro Metabolic Stability Assay

To validate the half-life differences described above, the following LC-MS/MS workflow is the industry standard for comparative stability profiling.

### Materials

- Matrix: Pooled Human Serum (pH 7.4) or Liver Microsomes (with NADPH regenerating system).

- Internal Standard (IS): Propranolol or Tolbutamide (for microsomes); Deuterated analog of analyte (for serum).
- Quenching Solution: Acetonitrile (ACN) with 0.1% Formic Acid.

## Step-by-Step Methodology

- Preparation:
  - Prepare 1 mM stock solutions of the
    - and
    - peptide analogs in DMSO.
  - Dilute to 1  $\mu$ M working concentration in pre-warmed (37°C) human serum.
- Incubation:
  - Incubate samples in a shaking water bath at 37°C.
  - Timepoints: 0, 5, 15, 30, 60, 120, 240 minutes (extend to 24h/48h for -peptides).
- Sampling & Quenching:
  - At each timepoint, remove 50  $\mu$ L of the reaction mixture.
  - Immediately add 200  $\mu$ L of ice-cold Quenching Solution (containing Internal Standard) to precipitate proteins and stop enzymatic activity.
- Processing:
  - Vortex for 1 min; Centrifuge at 10,000 x g for 10 min at 4°C.
  - Transfer supernatant to LC vials.
- Analysis (LC-MS/MS):

- Column: C18 Reverse Phase (e.g., Waters BEH C18).
- Mobile Phase: Gradient elution (Water/ACN + 0.1% Formic Acid).
- Detection: MRM (Multiple Reaction Monitoring) mode for specific parent ion fragment transitions.
- Calculation:
  - Plot  
  
vs. Time.
  - Calculate slope (  
  
).
  - .

## Visualization: Stability Assay Workflow

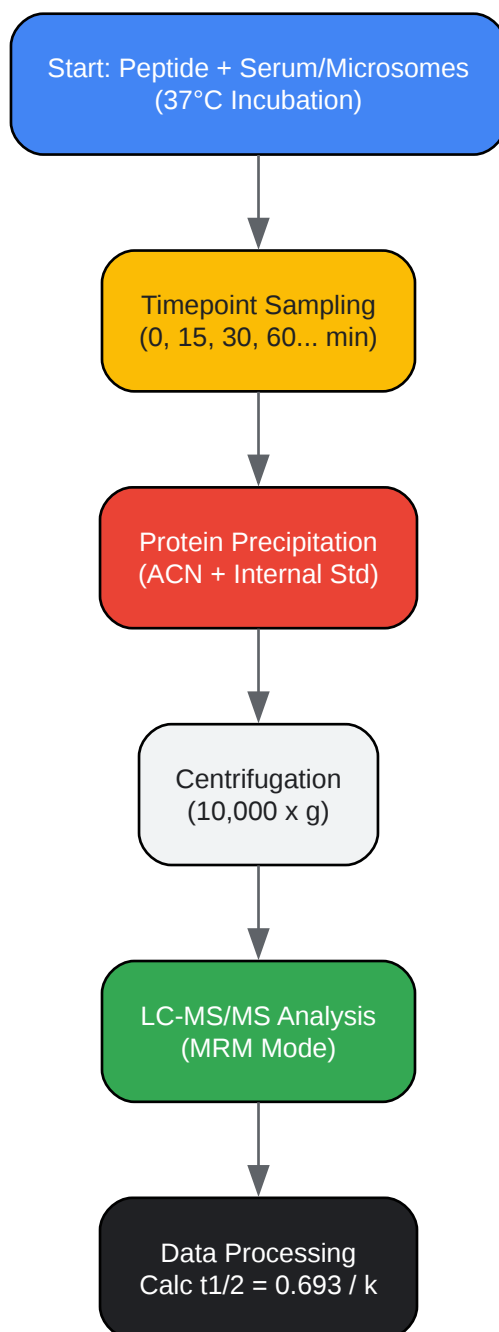

[Click to download full resolution via product page](#)

Caption: Standard LC-MS/MS workflow for determining in vitro metabolic stability ( ).

## Synthesis of Findings & Application

For drug development professionals, the choice between

- and

-peptides containing 2,3-dimethoxy groups depends on the therapeutic goal:

- Use

- Analogues (with 2,3-dimethoxy) when:

- The target receptor strictly requires an

- helical or turn conformation that cannot be mimicked by a

- foldamer.

- Short duration of action is desired (e.g., acute pain management with reduced systemic accumulation).

- Note: You will likely need to employ additional stabilization strategies (cyclization, N-methylation) to achieve a viable drug profile.

- Use

- Analogues (with 2,3-dimethoxy) when:

- Systemic longevity is critical. The combination of the

- backbone and the lipophilic 2,3-dimethoxy group creates a highly stable, bioavailable scaffold.

- Oral bioavailability is a target (enzymatic resistance in the GI tract).

- The 2,3-dimethoxy group is used to tune receptor selectivity (e.g., in opioid receptors, shifting preference between

- and

- subtypes) while ensuring the drug survives first-pass metabolism.

## References

- Steer, D. L., Lew, R. A., Perlmutter, P., Smith, A. I., & Aguilar, M. I. (2002). Beta-amino acids: Versatile peptidomimetics. *Current Medicinal Chemistry*. [Link](#)
- Seebach, D., & Gardiner, J. (2008). Beta-peptidic peptidomimetics. *Accounts of Chemical Research*. [Link](#)
- Gellman, S. H. (1998). Foldamers: A manifesto. *Accounts of Chemical Research*. [Link](#)
- Werder, M., et al. (1999). The biological stability of beta-peptides. *Helvetica Chimica Acta*. [Link](#)
- Geueke, B., & Kohler, H. P. (2007). Bacterial beta-peptidyl aminopeptidases: on the hydrolytic degradation of beta-peptides. *Applied Microbiology and Biotechnology*. [Link](#)

#### *Need Custom Synthesis?*

*BenchChem offers custom synthesis for rare earth carbides and specific isotopic labeling.*

*Email: [info@benchchem.com](mailto:info@benchchem.com) or [Request Quote Online](#).*

## Sources

- 1. [pdf.benchchem.com](https://pdf.benchchem.com) [[pdf.benchchem.com](https://pdf.benchchem.com)]
- 2. The proteolytic stability of 'designed' beta-peptides containing alpha-peptide-bond mimics and of mixed alpha,beta-peptides: application to the construction of MHC-binding peptides - PubMed [[pubmed.ncbi.nlm.nih.gov](https://pubmed.ncbi.nlm.nih.gov)]
- 3. How to Enhance the Pharmacokinetic Stability of Peptides? - Creative Peptides [[creative-peptides.com](https://creative-peptides.com)]
- 4. [pubs.acs.org](https://pubs.acs.org) [[pubs.acs.org](https://pubs.acs.org)]
- To cite this document: BenchChem. [Biological Half-Life Comparison: Alpha- vs. Beta-Peptides Containing 2,3-Dimethoxy Groups]. BenchChem, [2026]. [Online PDF]. Available at: [<https://www.benchchem.com/product/b7815930/docs#biological-half-life-comparison-alpha-vs-beta-peptides-containing-2-3-dimethoxy-groups>]

---

#### Disclaimer & Data Validity:

The information provided in this document is for Research Use Only (RUO) and is strictly not intended for diagnostic or therapeutic procedures. While BenchChem strives to provide accurate protocols, we make no warranties, express or implied, regarding the fitness of this product for every specific experimental setup.

**Technical Support:** The protocols provided are for reference purposes. Unsure if this reagent suits your experiment?

**Need Industrial/Bulk Grade?** [Request Custom Synthesis Quote](#)

## BenchChem

Our mission is to be the trusted global source of essential and advanced chemicals, empowering scientists and researchers to drive progress in science and industry.

### Contact

Address: 3281 E Guasti Rd  
Ontario, CA 91761, United States  
Phone: (601) 213-4426  
Email: [info@benchchem.com](mailto:info@benchchem.com)

[Contact our Ph.D. Support Team for a compatibility check](#)