

# (E)-Isomer Stability of 2,6-Substituted Cinnamic Acids: A Technical Guide

**Author:** BenchChem Technical Support Team. **Date:** February 2026

## Compound of Interest

Compound Name: *(2e)-3-(2,6-Dichlorophenyl)acrylic acid*

Cat. No.: B7807815

[Get Quote](#)

## Executive Summary

In medicinal chemistry, 2,6-substituted cinnamic acids represent a privileged scaffold. The introduction of substituents at both ortho positions (2,6-disubstitution) creates a unique steric environment that forces the phenyl ring out of planarity with the alkene system. This Steric Inhibition of Resonance (SIR) alters the electronic landscape, metabolic stability, and binding affinity compared to unsubstituted analogs. While the (E)-isomer is thermodynamically favored, the high rotational barrier and potential for photoisomerization require specific handling protocols to ensure configurational integrity during synthesis and storage.

## Structural Dynamics & Steric Inhibition of Resonance

The defining feature of 2,6-substituted cinnamic acids is the steric clash between the ortho-substituents and the vinyl protons (or the carbonyl oxygen, depending on conformation).

## The Orthogonality Effect

In unsubstituted cinnamic acid, the phenyl ring and the acrylic acid moiety are coplanar, maximizing

-conjugation.

- 2,6-Substitution: Substituents (e.g., -Cl, -Me, -OMe) occupy the space required for the vinylic proton ( or ).
- Consequence: To relieve this strain, the phenyl ring rotates around the bond. The dihedral angle deviates significantly from (often ), decoupling the aromatic -system from the alkene.

## Thermodynamic Stability ( vs. )

Despite the steric twist, the (E)-isomer (trans) remains thermodynamically superior to the (Z)-isomer (cis).

- -Isomer: The phenyl ring and the carboxylic acid group are on opposite sides. The primary clash is between the 2,6-substituents and the vinylic proton ( ).
- -Isomer: The phenyl ring and the carboxylic acid group are on the same side. The steric clash is between the 2,6-substituents and the bulky carboxylic acid moiety. This interaction is energetically prohibitive, making the -isomer highly unstable and difficult to isolate without rapid reversion or decomposition.

## Visualization of Steric Pathways

The following diagram illustrates the steric interactions and the isomerization energy landscape.

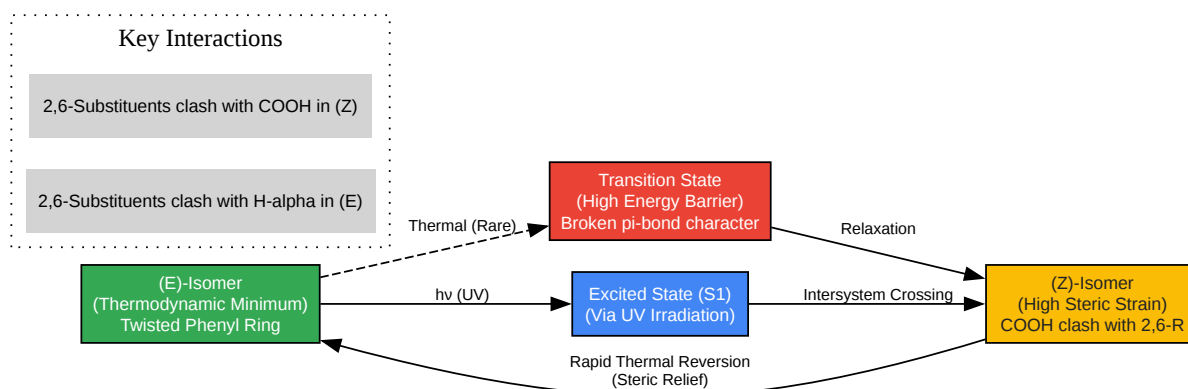

[Click to download full resolution via product page](#)

Figure 1: Isomerization dynamics of 2,6-substituted cinnamic acids. Note the rapid thermal reversion of Z to E due to massive steric strain.

## Stability Profile & Degradation Risks

### Photochemical Instability (The Primary Risk)

While thermally stable, 2,6-substituted cinnamic acids are photo-labile.

- Mechanism: Absorption of UV light (typically 280–320 nm) promotes the molecule to a singlet excited state. Intersystem crossing allows rotation around the C=C bond.
- Observation: Upon exposure to ambient laboratory light (fluorescent), an equilibrium mixture (photostationary state) forms. Due to the high energy of the 2,6-substituted -isomer, the equilibrium still heavily favors , but trace impurities (1–5%) can complicate biological assays.
- Mitigation: All synthesis and storage must be performed in amber glassware or under low-energy (red/yellow) light.

## Chemical Stability: Decarboxylation

Cinnamic acids can undergo thermal decarboxylation to form styrenes.

- Risk Factor: 2,6-Electron Donating Groups (e.g., 2,6-dimethoxy) stabilize the intermediate carbocation/transition state, accelerating decarboxylation at high temperatures (C) or in acidic media.
- Protocol: Avoid prolonged heating in high-boiling solvents (DMSO, DMF) without base.

## Synthesis Strategy: Ensuring (E)-Selectivity

Synthesizing the

-isomer with high purity requires selecting a method that accommodates the steric bulk of the aldehyde.

### Method Selection Matrix

Method	Suitability for 2,6-Substituted Systems	Pros	Cons
Knoevenagel Condensation	High	Scalable, cost-effective, thermodynamic control favors	Requires forcing conditions (heat/base) for hindered aldehydes.
Horner-Wadsworth-Emmons (HWE)	Medium	Mild conditions.	Steric bulk at the aldehyde can slow reaction; expensive reagents.
Heck Coupling	Low	Versatile for simple systems.	2,6-substitution on the aryl halide severely hinders Pd insertion; often low yields.

## Recommended Protocol: Modified Knoevenagel Condensation

For 2,6-substituted benzaldehydes, standard conditions (piperidine/ethanol) are often too slow. The Verley-Doebner modification is recommended.

Reagents:

- 2,6-Disubstituted Benzaldehyde (1.0 eq)
- Malonic Acid (1.2 eq)
- Pyridine (Solvent/Base)<sup>[1]</sup>
- Piperidine (Catalytic, 0.1 eq) or  
-alanine (Catalytic)

Step-by-Step Workflow:

- Dissolution: Dissolve the aldehyde and malonic acid in anhydrous pyridine (approx. 3-5 mL per mmol).
- Catalysis: Add catalytic piperidine.
- Activation: Heat the reaction mixture to 80–100°C. Note: The steric bulk raises the activation energy; room temperature stirring is insufficient.
- Monitoring: Monitor CO<sub>2</sub> evolution (bubbling). Reaction is complete when bubbling ceases (typically 2–6 hours).
- Workup (Critical for Isomer Purity):
  - Pour the reaction mixture into ice-cold HCl (1M) to precipitate the acid.
  - Self-Validating Step: The  
-isomer is typically less soluble in water/acid than the

-isomer or side products. A solid precipitate usually indicates high

-content.

- Purification: Recrystallize from Ethanol/Water. Avoid column chromatography if possible to minimize light exposure and silica-catalyzed isomerization.

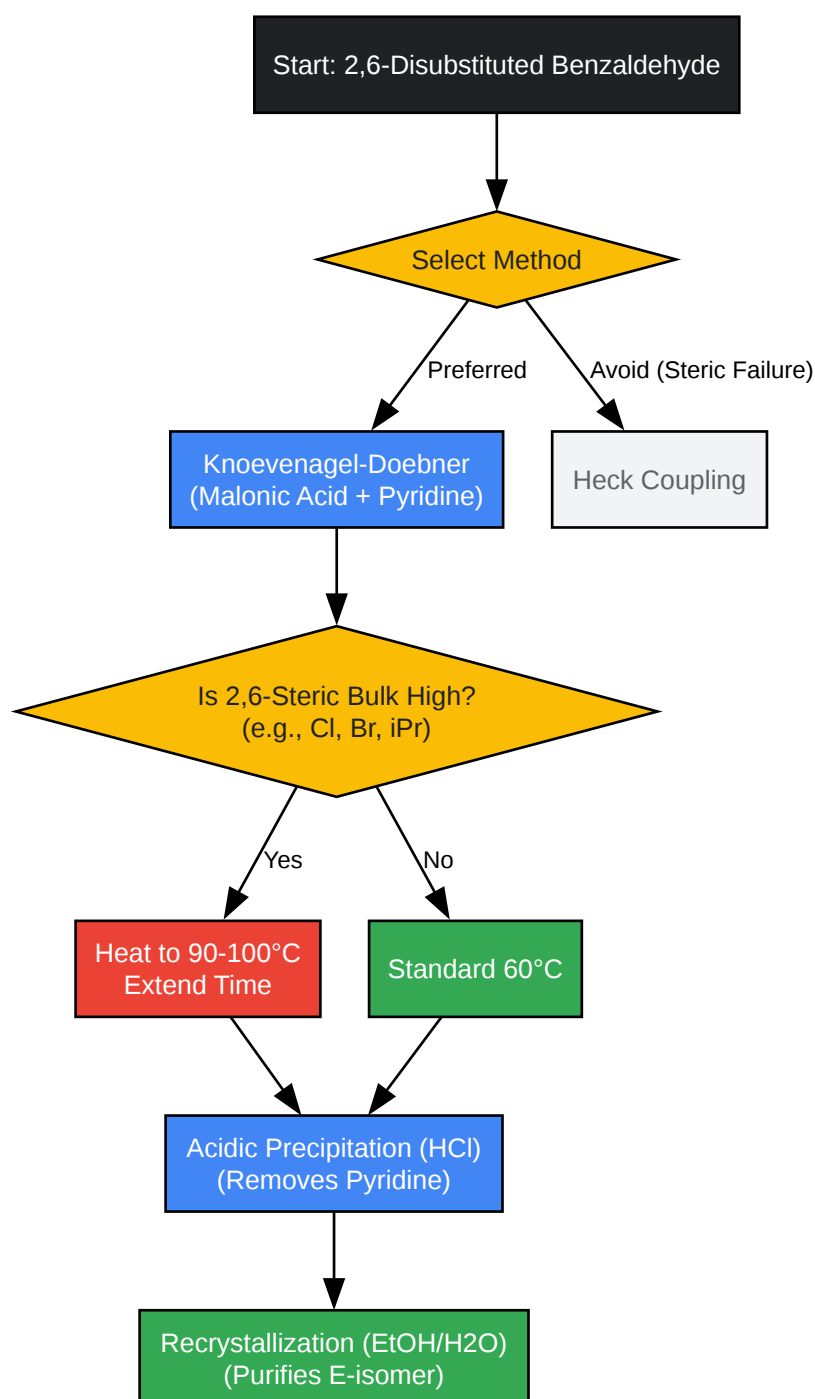

[Click to download full resolution via product page](#)

Figure 2: Decision tree and workflow for the synthesis of sterically hindered cinnamic acids.

## Analytical Validation

Confirming the stereochemistry is non-negotiable. The steric twist can subtly alter NMR shifts, but coupling constants remain diagnostic.

## Proton NMR ( <sup>1</sup>H-NMR)

The vinylic protons (

and

) provide the definitive proof of geometry.

Feature	(E)-Isomer (Trans)	(Z)-Isomer (Cis)	Notes
Coupling Constant ( )	15.0 – 16.5 Hz	10.0 – 12.5 Hz	The large -value is the primary confirmation of -geometry.
Chemical Shift ( )	7.5 – 8.0 ppm	6.5 – 7.0 ppm	is deshielded by the aromatic ring current in the -form.
NOE Signal	2,6-Substituents	2,6-Substituents	NOE confirms spatial proximity if -coupling is ambiguous.

Protocol:

- Acquire

H-NMR in DMSO-

or CDCl

.

- Expand the alkene region (6.0–8.0 ppm).
- Calculate  $J_{\text{H-C}}$  values. [2][3][4] If

values. [2][3][4] If

Hz, the product is pure

.

## Crystallography

Due to the high crystallinity of cinnamic acids, X-ray diffraction is often feasible and provides the ultimate proof of the "twisted" conformation caused by the 2,6-substituents.

## References

- Synthesis of Cinnamic Acids: Lombardo, M. (2024). [1][5][6][7] Knoevenagel Condensation Strategies. Royal Society of Chemistry. [\[Link\]](#)
- NMR Coupling Constants: University of Queensland. Coupling Constants in Cinnamic Acid Derivatives. [\[Link\]](#)
- Photoisomerization Dynamics: National Institutes of Health (NIH). Isomerization of E-Cinnamamides into Z-Cinnamamides. [\[Link\]](#)
- Decarboxylation Risks: ResearchGate. Decarboxylation of Substituted Cinnamic Acids. [\[Link\]](#)
- Steric Effects in NMR: Chemical Instrumentation Facility, Iowa State University. NMR Coupling Constants Guide. [\[Link\]](#)

### Need Custom Synthesis?

BenchChem offers custom synthesis for rare earth carbides and specific isotopic labeling.

Email: [info@benchchem.com](mailto:info@benchchem.com) or [Request Quote Online](#).

## Sources

- [1. pubs.rsc.org \[pubs.rsc.org\]](https://pubs.rsc.org)
- [2. NMR Coupling Constants | Chemical Instrumentation Facility \[cif.iastate.edu\]](https://cif.iastate.edu)
- [3. The Duke NMR Center Coupling constants \[sites.duke.edu\]](https://sites.duke.edu)
- [4. espace.library.uq.edu.au \[espace.library.uq.edu.au\]](https://espace.library.uq.edu.au)
- [5. researchgate.net \[researchgate.net\]](https://researchgate.net)
- [6. Cinnamic Acid Derivatives and Their Biological Efficacy - PMC \[pmc.ncbi.nlm.nih.gov\]](https://pubmed.ncbi.nlm.nih.gov)
- [7. alfa-chemistry.com \[alfa-chemistry.com\]](https://alfa-chemistry.com)
- To cite this document: BenchChem. [(E)-Isomer Stability of 2,6-Substituted Cinnamic Acids: A Technical Guide]. BenchChem, [2026]. [Online PDF]. Available at: [\[https://www.benchchem.com/product/b7807815#e-isomer-stability-of-2-6-substituted-cinnamic-acids\]](https://www.benchchem.com/product/b7807815#e-isomer-stability-of-2-6-substituted-cinnamic-acids)

---

### Disclaimer & Data Validity:

The information provided in this document is for Research Use Only (RUO) and is strictly not intended for diagnostic or therapeutic procedures. While BenchChem strives to provide accurate protocols, we make no warranties, express or implied, regarding the fitness of this product for every specific experimental setup.

**Technical Support:** The protocols provided are for reference purposes. Unsure if this reagent suits your experiment? [[Contact our Ph.D. Support Team for a compatibility check](#)]

**Need Industrial/Bulk Grade?** [Request Custom Synthesis Quote](#)

## BenchChem

Our mission is to be the trusted global source of essential and advanced chemicals, empowering scientists and researchers to drive progress in science and industry.

### Contact

Address: 3281 E Guasti Rd  
Ontario, CA 91761, United States  
Phone: (601) 213-4426  
Email: [info@benchchem.com](mailto:info@benchchem.com)