

# Validating LNFPIII Structure: A Comparative Guide to NMR Spectroscopy

**Author:** BenchChem Technical Support Team. **Date:** April 2026

## Compound of Interest

Compound Name: *lacto-n-Fucopentaose III*

Cat. No.: *B7803940*

[Get Quote](#)

Content Type: Publish Comparison Guide Audience: Researchers, Senior Scientists, Drug Development Professionals Focus: Structural elucidation and validation of **Lacto-N-fucopentaose III** (LNFPIII)

## Executive Summary

**Lacto-N-fucopentaose III** (LNFPIII) is a biologically potent pentasaccharide containing the Lewis X (

) trisaccharide determinant.<sup>[1][2]</sup> Its role in immunomodulation—specifically in driving alternative macrophage activation and treating metabolic diseases—makes the validation of its precise stereochemistry and linkage critical.

The primary challenge in LNFPIII production and characterization is distinguishing it from its structural isomer, Lacto-N-fucopentaose II (LNFPII), which contains the Lewis A (

) determinant. While Mass Spectrometry (MS) offers superior sensitivity, it often struggles to unambiguously differentiate these regioisomers without extensive derivatization.

This guide establishes NMR Spectroscopy as the gold standard for LNFPIII validation. We provide a direct performance comparison with MS, a detailed technical protocol for NMR

structural assignment, and the specific spectral "fingerprints" required to confirm the motif.

## Part 1: The Structural Challenge (LNFPIII vs. LNFPII)

To validate LNFPIII, one must prove the specific glycosidic linkage positions on the N-acetylglucosamine (GlcNAc) residue. Both isomers share the same mass (

Da) and monosaccharide composition (Gal

, Glc

, Fuc

, GlcNAc

), but differ in connectivity:

- LNFPIII (Lewis X): Gal-

(1\$to

\alpha

\to\$3)]-GlcNAc...[1][3][4]

- LNFPII (Lewis A): Gal-

(1\$to

\alpha

\to\$4)]-GlcNAc...

This subtle "switch" of the Fucose and Galactose attachment points on the GlcNAc ring fundamentally alters biological activity.

## Structural Logic Diagram

The following diagram illustrates the critical linkage difference that NMR must resolve.

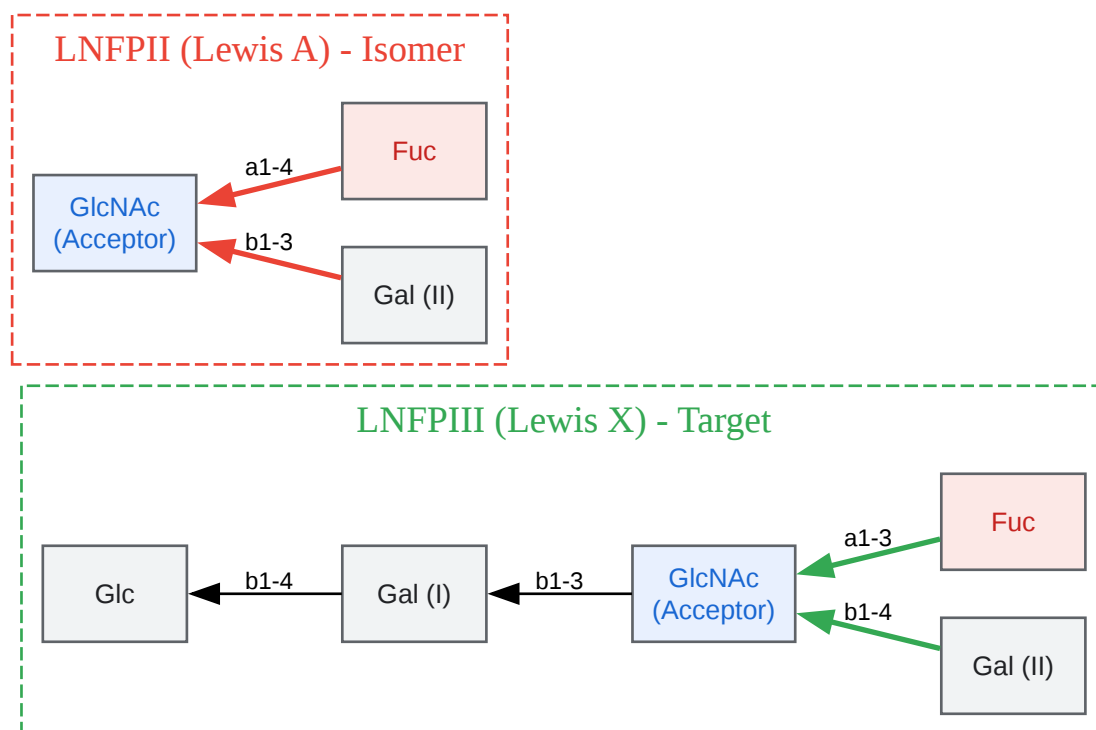

[Click to download full resolution via product page](#)

Caption: Structural comparison showing the critical Fucose/Galactose linkage swap on the GlcNAc residue between LNFPIII and LNFPII.

## Part 2: Strategic Comparison (NMR vs. MS)

While MS is indispensable for purity profiling and trace analysis, NMR is required for de novo structural certification.

| Feature            | NMR Spectroscopy (The Validator)   | Mass Spectrometry (MS/MS) (The Screener)  |
|--------------------|--|---|
| Primary Output     | Atom-to-atom connectivity & stereochemistry.   | Molecular mass & fragmentation patterns.  |
| Isomer Distinction | Definitive. Distinguishes vs linkages via scalar (HMBC) and spatial (NOESY) couplings. | Challenging. Requires specific collision energies or permethylation to distinguish linkage isomers. |
| Sample Requirement | High (mg preferred). Non-destructive.  | Low (picomole/femtomole). Destructive.  |
| Quantification     | Inherently quantitative (qNMR) without reference standards.                            | Requires isotopically labeled standards for absolute quantitation.                                  |
| Throughput         | Low (hours per sample for full 2D suite).  | High (minutes per sample).  |
| Best Use Case      | Batch Release Testing / Structural Proof.  | High-throughput Screening / PK Studies.   |

Verdict: Use MS to confirm mass and purity during synthesis/purification. Use NMR to certify the identity of the final LNFPIII product.

## Part 3: The NMR Validation Protocol

This protocol is designed to unambiguously assign the LNFPIII structure using a 600 MHz (or higher) spectrometer equipped with a CryoProbe.

### Sample Preparation

- Solvent: Dissolve

mg of lyophilized LNFPIII in

of

.

- Note: For detection of exchangeable amide protons (GlcNAc NH), use a

mixture, though

is sufficient for skeletal assignment.

- Reference: Add internal standard DSS (2,2-dimethyl-2-silapentane-5-sulfonate) at

.

- Temperature: Equilibrate at

(

).

## Experimental Workflow & Causality

| Experiment | Purpose                          | Critical Observation for LNFPIII   |
|------------|----------------------------------|--|
| 1D         | Quality check & Anomeric ID      | Identify 5 anomeric signals. The Fucose H1 is distinctively downfield ( ) and appears as a doublet with small coupling ( , indicating -linkage). |
| 2D COSY    | Spin System Identification       | Trace the scalar coupling network (H1 H2 H3...) to identify the isolated spin systems of the 5 monosaccharides.                                  |
| 2D TOCSY   | Full Ring Assignment             | Propagate magnetization from anomeric protons to the rest of the ring protons. Vital for assigning the GlcNAc ring protons H3 and H4.            |
| 2D HSQC    | Carbon Assignment                | Correlate protons to carbons. Key: Identify the Fucose C6 methyl ( , ) and GlcNAc C3/C4.   |
| 2D HMBC    | Linkage Proof (The "Killer App") | Detects long-range ( ) correlations across the glycosidic bond.  |

## The Validation Criteria (Data Interpretation)

To confirm LNFPIII and reject LNFPII, you must observe the following specific correlations:

### A. The Fucose Linkage (Lewis X Marker)[5]

- Target: Fucose

GlcNAc.

- HMBC Evidence: A cross-peak between Fuc H1 and GlcNAc C3.
  - Contrast: In LNFPII, this peak would appear between Fuc H1 and GlcNAc C4.
- NOESY Evidence: A strong NOE cross-peak between Fuc H1 and GlcNAc H3.

### B. The Galactose Linkage

- Target: Galactose

GlcNAc.

- HMBC Evidence: A cross-peak between Gal(II) H1 and GlcNAc C4.
  - Contrast: In LNFPII, this peak would appear between Gal(II) H1 and GlcNAc C3.

### C. Chemical Shift Fingerprints (Approximate

in

)

- Fucose H1:

ppm (d,

Hz).

- Fucose CH3:

ppm.

- GlcNAc N-Acetyl:

ppm.

- Note: Chemical shifts are sensitive to pH and temperature; rely on connectivity (HMBC) over absolute shift values.

## Part 4: Visualization of the Validation Logic

The following decision tree outlines the logical flow for accepting or rejecting a batch of LNFPIII based on NMR data.

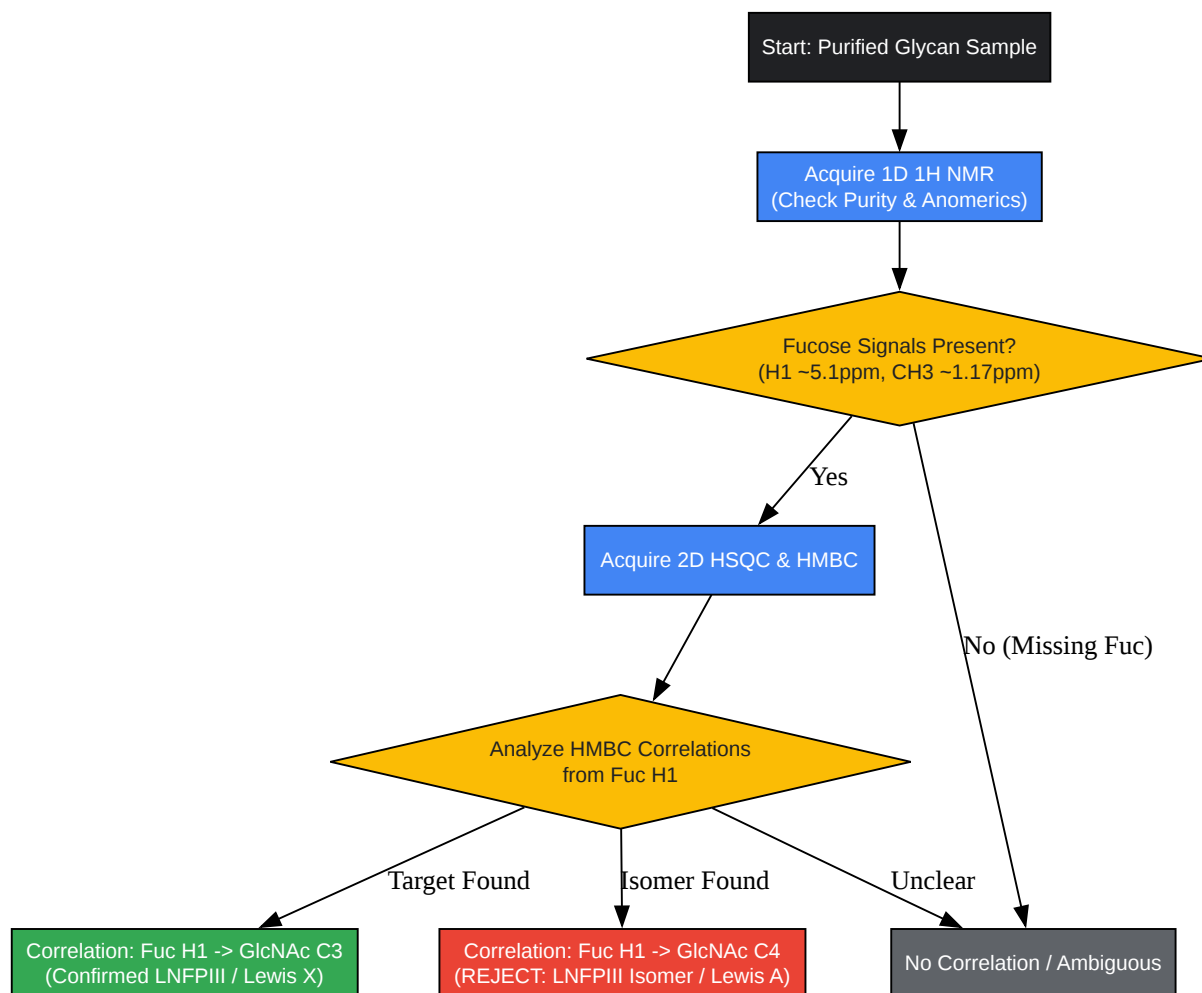

[Click to download full resolution via product page](#)

Caption: Decision tree for validating LNFPIII structure using HMBC connectivity.

## References

- Prerna Bhargava et al. (2012).[6] Immunomodulatory glycan LNFPIII alleviates hepatosteatosis and insulin resistance through direct and indirect control of metabolic pathways.[6] Nature Medicine.[6] [Link](#)
- Totten, S. M. et al. (2014). Rapid milk group classification by <sup>1</sup>H NMR analysis of Le and H epitopes in human milk oligosaccharide donor samples. Glycobiology. [Link](#)
- S.S. Silva et al. (2024). On the part that NMR should play in mass spectrometry metabolomics in natural products studies. Frontiers in Molecular Biosciences. [Link](#)
- BenchChem. (2025).[7][8] Resolving discrepancies between NMR and mass spectrometry data during characterization. [Link](#)
- K.A. Brown et al. (2021).[9] Lacto-N-fucopentaose-III ameliorates acute and persisting hippocampal synaptic plasticity and transmission deficits in a Gulf War Illness mouse model. Life Sciences. [Link](#)

### Need Custom Synthesis?

BenchChem offers custom synthesis for rare earth carbides and specific isotopic labeling.

Email: [info@benchchem.com](mailto:info@benchchem.com) or [Request Quote Online](#).

## Sources

- [1. Immunomodulatory Glycan Lacto-N-Fucopentaose III Requires Clathrin-Mediated Endocytosis To Induce Alternative Activation of Antigen-Presenting Cells - PMC \[pmc.ncbi.nlm.nih.gov\]](#)
- [2. Synthesis of the Tolerance-Inducing Oligosaccharide Lacto-N-Fucopentaose III Bearing an Activated Linker - PMC \[pmc.ncbi.nlm.nih.gov\]](#)
- [3. Lacto-N-fucopentaose III - IsoSep \[isosep.com\]](#)
- [4. scbt.com \[scbt.com\]](#)
- [5. <sup>1</sup>H NMR Metabolomics of Chinese Human Milk at Different Stages of Lactation among Secretors and Non-Secretors \[mdpi.com\]](#)
- [6. Immunomodulatory glycan LNFPIII alleviates hepatosteatosis and insulin resistance through direct and indirect control of metabolic pathways - PubMed](#)

[\[pubmed.ncbi.nlm.nih.gov\]](https://pubmed.ncbi.nlm.nih.gov)

- [7. pdf.benchchem.com \[pdf.benchchem.com\]](https://pdf.benchchem.com)
- [8. pdf.benchchem.com \[pdf.benchchem.com\]](https://pdf.benchchem.com)
- [9. medchemexpress.com \[medchemexpress.com\]](https://medchemexpress.com)
- To cite this document: BenchChem. [Validating LNFPIII Structure: A Comparative Guide to NMR Spectroscopy]. BenchChem, [2026]. [Online PDF]. Available at: [\[https://www.benchchem.com/product/b7803940/docs#validating-Infpiii-structure-a-comparative-guide-to-nmr-spectroscopy\]](https://www.benchchem.com/product/b7803940/docs#validating-Infpiii-structure-a-comparative-guide-to-nmr-spectroscopy)

---

### Disclaimer & Data Validity:

The information provided in this document is for Research Use Only (RUO) and is strictly not intended for diagnostic or therapeutic procedures. While BenchChem strives to provide accurate protocols, we make no warranties, express or implied, regarding the fitness of this product for every specific experimental setup.

**Technical Support:** The protocols provided are for reference purposes. Unsure if this reagent suits your experiment?

**Need Industrial/Bulk Grade?** [Request Custom Synthesis Quote](#)

## BenchChem

Our mission is to be the trusted global source of essential and advanced chemicals, empowering scientists and researchers to drive progress in science and industry.

### Contact

Address: 3281 E Guasti Rd  
Ontario, CA 91761, United States  
Phone: (601) 213-4426  
Email: [info@benchchem.com](mailto:info@benchchem.com)

[Contact our Ph.D. Support Team for a compatibility check](#)

