

Technical Support Center: Preventing LNFPIII Degradation During Conjugation

Author: BenchChem Technical Support Team. **Date:** April 2026

Compound of Interest

Compound Name: *lacto-n-Fucopentaose III*

Cat. No.: B7803940

[Get Quote](#)

Welcome to the technical support center for **Lacto-N-fucopentaose III** (LNFPIII) bioconjugation. This guide is designed for researchers, scientists, and drug development professionals who are leveraging the unique immunomodulatory properties of LNFPIII in their work.[1][2][3][4][5] The integrity of this complex pentasaccharide is paramount for its biological function, yet the very chemical reactions designed to attach it to proteins, nanoparticles, or surfaces can inadvertently lead to its degradation.

This resource provides in-depth, experience-driven troubleshooting advice and validated protocols to help you navigate the complexities of LNFPIII conjugation, ensuring the preservation of its critical structural motifs.

Understanding LNFPIII and Its Susceptibility to Degradation

Lacto-N-fucopentaose III is a pentasaccharide with the structure $\text{Gal}\beta\text{1-4}(\text{Fuc}\alpha\text{1-3})\text{GlcNAc}\beta\text{1-3Gal}\beta\text{1-4Glc}$. [6] Its biological activity is intrinsically linked to this precise arrangement of monosaccharide units, particularly the terminal Lewis X (LeX) trisaccharide. [5][7] The linkages connecting these sugar units, known as glycosidic bonds, are the primary sites of potential degradation.

The most vulnerable linkage in LNFPIII is the $\alpha(1-3)$ fucosidic bond connecting fucose to the GlcNAc residue. This bond is particularly susceptible to acid-catalyzed hydrolysis.[8] Even mildly acidic conditions, which can be a prerequisite for certain conjugation chemistries, can lead to the cleavage of fucose, rendering the entire molecule biologically inactive for its intended purpose.

Diagram: LNFPIII Structure and Points of "Attack"

This diagram illustrates the structure of LNFPIII and highlights the glycosidic bonds that are most susceptible to cleavage during conjugation procedures.

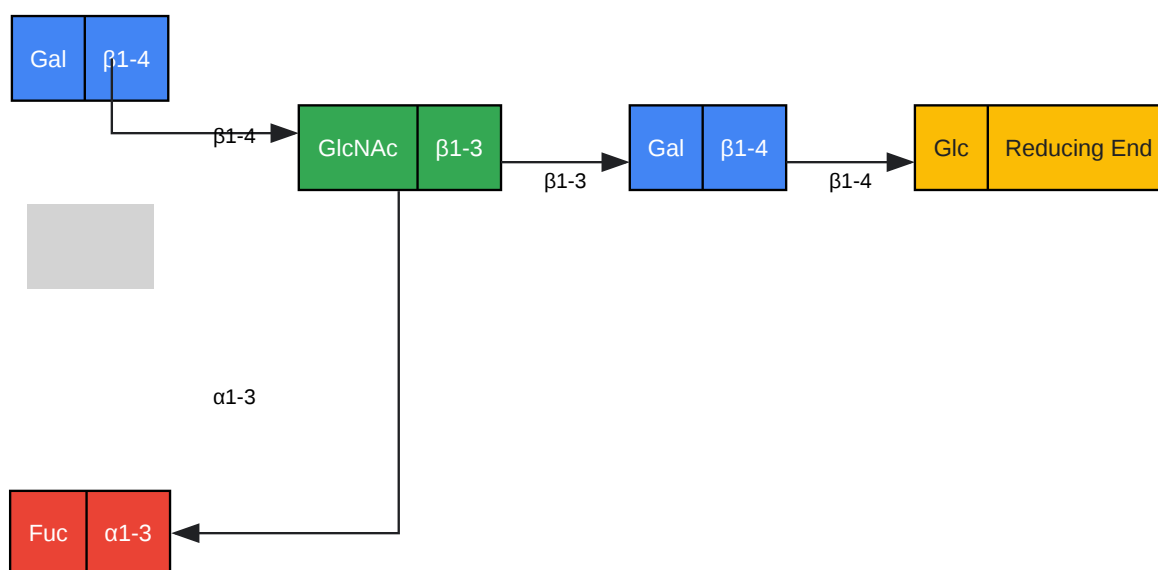

[Click to download full resolution via product page](#)

Caption: Structure of LNFPIII highlighting the acid-sensitive $\alpha(1-3)$ fucosidic bond.

Troubleshooting Guide & FAQs

This section addresses common issues encountered during LNFPIII conjugation in a direct question-and-answer format.

Issue: Low or No Biological Activity of the Final Conjugate

Q1: My LNFPIII-protein conjugate shows significantly reduced or no activity compared to the free glycan. I suspect degradation. What is the most likely cause?

A1: The most probable cause is the cleavage of the terminal fucose residue due to acidic conditions during your conjugation or purification steps. The $\alpha(1-3)$ fucosidic bond is highly labile.^[8] Review every step of your protocol for sources of low pH.

- **Conjugation Buffer:** What is the pH of your reaction buffer? Standard NHS-ester chemistries often run at pH 8.0-8.5, which is generally safe. However, other methods, like oxime ligations, may require mildly acidic conditions (pH 4.5-6.0), which can be detrimental.^[9]
- **Reagent Acidity:** Have you checked the pH after adding all reagents? Some stock solutions (e.g., activation reagents dissolved in anhydrous solvents like DMF or DMSO) can become acidic upon introduction to an aqueous buffer.
- **Purification:** Are you using purification methods that expose the conjugate to low pH? For example, some size-exclusion chromatography columns are stored in acidic solutions, or elution from affinity columns might be performed with a low-pH buffer.

Corrective Action:

- **pH Monitoring:** Measure the pH of your reaction mixture after all components have been added. Adjust if necessary with a non-interfering base (e.g., 0.1 M NaOH).
- **Buffer Exchange:** Ensure your protein and LNFPIII starting materials are in the correct, pH-stable buffer before initiating the reaction. Use methods like dialysis, ultrafiltration, or gel filtration.^[10]
- **Alternative Chemistries:** If your current method requires low pH, consider alternative conjugation strategies that proceed at neutral or slightly alkaline pH, such as those involving maleimide-thiol coupling or click chemistry.

Issue: Inconsistent Conjugation Efficiency

Q2: I am seeing significant batch-to-batch variability in my conjugation efficiency. Could LNFPIII degradation be a factor?

A2: Yes, inconsistent degradation can certainly lead to variable conjugation yields. If the reducing end of LNFPIII (the glucose unit) is where your conjugation chemistry is targeted (e.g., via reductive amination), any degradation of the glycan will reduce the number of available sites for conjugation.

- **Reagent Quality:** Are you using fresh, high-quality reagents? Older crosslinkers or reducing agents (like sodium cyanoborohydride) can degrade, leading to inconsistent performance and potentially altering reaction pH.
- **Enzymatic Contamination:** A less common but possible issue is contamination of your protein sample with glycosidase enzymes. These enzymes can cleave glycosidic bonds with high specificity and efficiency.^{[11][12]} This is a particular risk if your protein is produced in a system that also expresses glycosidases.

Corrective Action:

- **Reagent Handling:** Use fresh, anhydrous solvents for dissolving reagents like NHS esters. ^[13] Prepare reducing agent solutions immediately before use.
- **Test for Enzymatic Activity:** If you suspect glycosidase contamination, you can incubate your protein with a control oligosaccharide and analyze for degradation over time. If present, consider adding a broad-spectrum glycosidase inhibitor to your reaction or further purifying your protein.

Issue: Verifying LNFPIII Integrity Post-Conjugation

Q3: How can I be certain that LNFPIII is intact on my final conjugate? Standard protein assays don't give me this information.

A3: This is a critical QC step. You must use analytical methods capable of assessing the glycan structure itself.

- **High-Performance Anion-Exchange Chromatography with Pulsed Amperometric Detection (HPAE-PAD):** This is the gold standard for analyzing intact, underivatized carbohydrates.[14][15][16] You would first need to release the glycans from the protein conjugate (e.g., using PNGase F if it's N-linked, though LNFPIII is often conjugated via a linker) and then analyze the released glycan profile. The absence or reduction of the LNFPIII peak compared to a standard would indicate degradation.
- **Mass Spectrometry (MS):** MALDI-TOF or ESI-MS can be used to analyze the mass of the entire conjugate. While this can confirm the addition of the glycan, it may not be sensitive enough to detect the loss of a single fucose residue (mass ~146 Da) on a large protein. However, analyzing released glycans by MS is a powerful verification tool.
- **Lectin or Antibody Binding Assays:** An ELISA-style assay using a lectin or antibody that specifically recognizes the intact LNFPIII or Lewis X structure can be a highly effective functional check.[7] A loss of signal would indicate that the binding epitope has been destroyed, likely through fucose cleavage.

Key Experimental Protocols

The following protocols are designed to minimize degradation risk.

Protocol 1: Buffer Exchange for Reagent Compatibility

Objective: To remove interfering substances and ensure both the protein and LNFPIII are in an optimal, non-degrading buffer prior to conjugation.

Parameter	Recommendation	Rationale
Method	Spin Desalting Columns / Diafiltration	Rapid and efficient removal of low molecular weight contaminants (e.g., Tris, glycine, azide) that interfere with NHS-ester chemistry.[10]
Target Buffer	1X PBS or 100 mM HEPES, pH 7.2-7.5	Neutral pH is safe for glycosidic bonds and compatible with many common crosslinkers. Avoids the primary amine in Tris buffer.
Temperature	4°C to Room Temperature	Lower temperatures can help maintain protein stability.[17]

Step-by-Step Methodology:

- Equilibrate a spin desalting column (e.g., Zeba™ Spin Desalting Column) appropriate for your sample volume and molecular weight cutoff by washing it three times with the target conjugation buffer, according to the manufacturer's instructions.
- Carefully apply your protein or LNFPIII sample to the center of the compacted resin bed.
- Centrifuge the column according to the manufacturer's protocol to collect the buffer-exchanged sample.
- Verify the protein concentration after exchange using a standard method (e.g., BCA assay).

Protocol 2: Quality Control Analysis by HPAE-PAD

Objective: To verify the integrity of LNFPIII after a conjugation reaction by analyzing the released glycan.

Step-by-Step Methodology:

- Glycan Release: Treat a small aliquot of your final, purified conjugate with a chemical or enzymatic method appropriate for cleaving the linker used in the conjugation. (This step is highly dependent on your specific linker chemistry).
- Sample Cleanup: Purify the released glycans from the protein and other reaction components using a C18 or graphitized carbon solid-phase extraction (SPE) cartridge.
- HPAE-PAD Analysis:
 - System: Use a high-performance anion-exchange chromatography system equipped with a pulsed amperometric detector and a gold working electrode.[18]
 - Column: A column designed for carbohydrate analysis (e.g., Thermo Scientific™ Dionex™ CarboPac™ series) is required.[19]
 - Elution: Separation is achieved using an alkaline eluent gradient, typically a combination of sodium hydroxide and sodium acetate.[18]
 - Detection: The separated glycans are detected directly and without derivatization by pulsed amperometry.[15][16]
- Data Interpretation: Compare the chromatogram of your released glycan sample to that of an intact LNFPIII standard. The retention time of the major peak should match. The appearance of earlier-eluting peaks or a diminished LNFPIII peak indicates degradation.

Diagram: Troubleshooting Workflow for LNFPIII Conjugation

This decision tree provides a logical path for troubleshooting common issues during LNFPIII conjugation experiments.

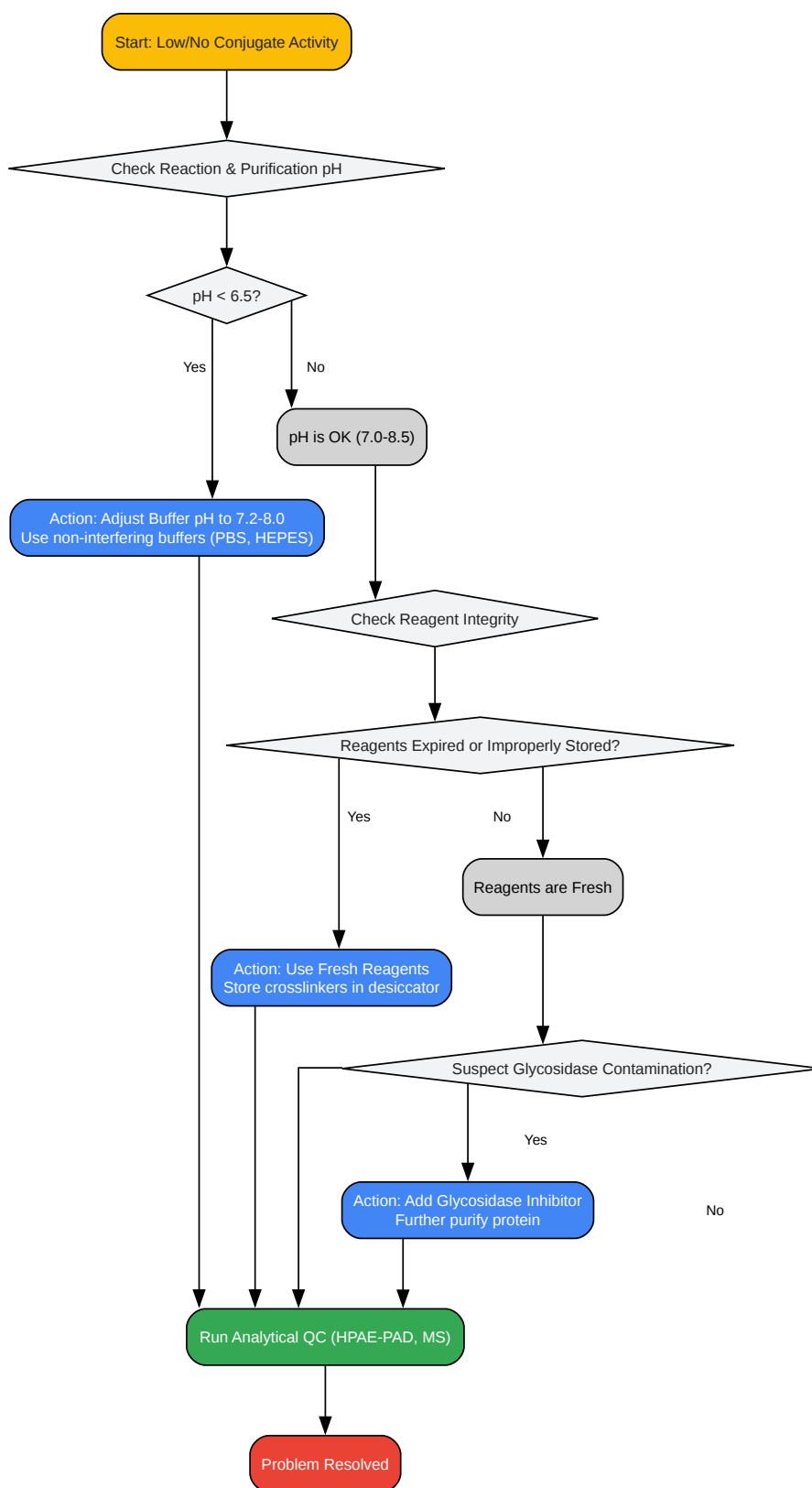

[Click to download full resolution via product page](#)

Caption: A decision tree for troubleshooting LNFPIII conjugation issues.

References

- The glycosidic bond cleavage and desulfation investigation of fucosylated glycosaminoglycan during mild acid hydrolysis through structural analysis of the resulting oligosaccharides. PubMed. (2021-12-18). Available from: [\[Link\]](#)
- HIGHLY SENSITIVE ANALYSIS OF GLYCANS IN THERAPEUTIC GLYCOPROTEINS. Solvias. Available from: [\[Link\]](#)
- HPAE-PAD - A very useful tool for glycan analysis. Separation Science. (2023-12-08). Available from: [\[Link\]](#)
- Analysis of N-Glycans using HPAEC-PAD/MS. Antec Scientific. Available from: [\[Link\]](#)
- Monoclonal Antibodies Generated against Glycoconjugates Recognize Chemical Linkers. MDPI. (2020-09-15). Available from: [\[Link\]](#)
- Immunomodulatory Glycan **Lacto-N-Fucopentaose III** Requires Clathrin-Mediated Endocytosis To Induce Alternative Activation of Antigen-Presenting Cells. PMC. Available from: [\[Link\]](#)
- **Lacto-N-fucopentaose III**. PubChem. Available from: [\[Link\]](#)
- Immune modulation by **Lacto-N-fucopentaose III** in experimental autoimmune encephalomyelitis. PMC. Available from: [\[Link\]](#)
- Troubleshooting Guides. Creative Biolabs. (2024-11-07). Available from: [\[Link\]](#)
- **Lacto-N-fucopentaose III** (LNFP III). Elicityl. Available from: [\[Link\]](#)
- Research Progress on the Degradation of Human Milk Oligosaccharides (HMOs) by Bifidobacteria. MDPI. (2025-01-30). Available from: [\[Link\]](#)
- The immunomodulatory glycan LNFP III initiates alternative activation of murine macrophages in vivo. PMC. Available from: [\[Link\]](#)
- Recent advances in photoinduced glycosylation: oligosaccharides, glycoconjugates and their synthetic applications. RSC Publishing. (2017-05-17). Available from: [\[Link\]](#)

- 2.4 Stability of N-Glycosidic Bonds. Carbohydrates - Structure and Function. Available from: [\[Link\]](#)
- Immunomodulatory glycan **lacto-N-fucopentaose III** requires clathrin-mediated endocytosis to induce alternative activation of antigen-presenting cells. PubMed. (2014-02-24). Available from: [\[Link\]](#)
- **Lacto-N-fucopentaose III**. Creative Biolabs. Available from: [\[Link\]](#)
- Bioconjugation Optimization & Troubleshooting. AbOliGo. Available from: [\[Link\]](#)
- Human milk oligosaccharide (HMO) structures. ResearchGate. Available from: [\[Link\]](#)
- Glycoconjugations of Biomolecules by Chemical Methods. PMC. Available from: [\[Link\]](#)
- Structure of LNFPIII, LNnT, and conjugates. ResearchGate. Available from: [\[Link\]](#)
- Glycosidic bond. Wikipedia. Available from: [\[Link\]](#)
- Glycosidic bond. Khan Academy. Available from: [\[Link\]](#)
- Assessing the Beneficial Effects of the Immunomodulatory Glycan LNFPIII on Gut Microbiota and Health in a Mouse Model of Gulf War Illness. MDPI. (2020-09-27). Available from: [\[Link\]](#)
- Acid Hydrolysis of Glycosidic Bonds in Polysaccharides: Modelling and Stochastic Simulation. ResearchGate. Available from: [\[Link\]](#)
- Multivalent glycocyclopeptides: conjugation methods and biological applications. PMC. Available from: [\[Link\]](#)
- Glycoconjugations of Biomolecules by Chemical Methods. ResearchGate. (2020-11-04). Available from: [\[Link\]](#)
- The immunomodulatory glycan LNFPIII initiates alternative activation of murine macrophages in vivo. PubMed. (2008-03-28). Available from: [\[Link\]](#)
- Reliable N-Glycan Analysis—Removal of Frequently Occurring Oligosaccharide Impurities by Enzymatic Degradation. MDPI. (2023-02-15). Available from: [\[Link\]](#)

- Enzymatic Degradation of the Most Common Aliphatic Bio-Polyesters and Evaluation of the Mechanisms Involved: An Extended Study. MDPI. (2022-04-30). Available from: [\[Link\]](#)

Need Custom Synthesis?

BenchChem offers custom synthesis for rare earth carbides and specific isotopic labeling.

Email: info@benchchem.com or [Request Quote Online](#).

Sources

- 1. Immune modulation by Lacto-N-fucopentaose III in experimental autoimmune encephalomyelitis - PMC [[pmc.ncbi.nlm.nih.gov](https://pubmed.ncbi.nlm.nih.gov)]
- 2. The immunomodulatory glycan LNFPIII initiates alternative activation of murine macrophages in vivo - PMC [[pmc.ncbi.nlm.nih.gov](https://pubmed.ncbi.nlm.nih.gov)]
- 3. Immunomodulatory glycan lacto-N-fucopentaose III requires clathrin-mediated endocytosis to induce alternative activation of antigen-presenting cells - PubMed [pubmed.ncbi.nlm.nih.gov]
- 4. mdpi.com [mdpi.com]
- 5. The immunomodulatory glycan LNFPIII initiates alternative activation of murine macrophages in vivo - PubMed [pubmed.ncbi.nlm.nih.gov]
- 6. Lacto-N-fucopentaose III (LNFP III) (>90% NMR) [elicityl-oligotech.com]
- 7. mdpi.com [mdpi.com]
- 8. The glycosidic bond cleavage and desulfation investigation of fucosylated glycosaminoglycan during mild acid hydrolysis through structural analysis of the resulting oligosaccharides - PubMed [pubmed.ncbi.nlm.nih.gov]
- 9. Multivalent glycocyclopeptides: conjugation methods and biological applications - PMC [[pmc.ncbi.nlm.nih.gov](https://pubmed.ncbi.nlm.nih.gov)]
- 10. Troubleshooting Guides - Creative Biolabs [creative-biolabs.com]
- 11. Khan Academy [khanacademy.org]
- 12. mdpi.com [mdpi.com]
- 13. vectorlabs.com [vectorlabs.com]
- 14. solvias.com [solvias.com]

- [15. sepscience.com \[sepscience.com\]](#)
- [16. jasco.ro \[jasco.ro\]](#)
- [17. pdf.benchchem.com \[pdf.benchchem.com\]](#)
- [18. documents.thermofisher.com \[documents.thermofisher.com\]](#)
- [19. lcms.cz \[lcms.cz\]](#)
- To cite this document: BenchChem. [Technical Support Center: Preventing LNFPIII Degradation During Conjugation]. BenchChem, [2026]. [Online PDF]. Available at: [<https://www.benchchem.com/product/b7803940/docs#technical-support-center-preventing-lnfpiii-degradation-during-conjugation>]

Disclaimer & Data Validity:

The information provided in this document is for Research Use Only (RUO) and is strictly not intended for diagnostic or therapeutic procedures. While BenchChem strives to provide accurate protocols, we make no warranties, express or implied, regarding the fitness of this product for every specific experimental setup.

Technical Support: The protocols provided are for reference purposes. Unsure if this reagent suits your experiment?

Need Industrial/Bulk Grade? [Request Custom Synthesis Quote](#)

BenchChem

Our mission is to be the trusted global source of essential and advanced chemicals, empowering scientists and researchers to drive progress in science and industry.

Contact

Address: 3281 E Guasti Rd

Ontario, CA 91761, United States

Phone: (601) 213-4426

Email: info@benchchem.com

Contact our Ph.D. Support Team for a compatibility check