

Technical Support Center: Optimizing LNFPIII Concentration for Macrophage Assays

Author: BenchChem Technical Support Team. **Date:** April 2026

Compound of Interest

Compound Name: *lacto-n-Fucopentaose III*

Cat. No.: B7803940

[Get Quote](#)

Welcome to the technical support center for the utilization of **Lacto-N-fucopentaose III** (LNFPIII) in macrophage assays. This guide is designed for researchers, scientists, and drug development professionals to provide in-depth, field-proven insights into optimizing experimental conditions and troubleshooting common issues. Our goal is to ensure the scientific integrity and reproducibility of your results by explaining the "why" behind the "how."

I. Core Principles of LNFPIII in Macrophage Biology

Lacto-N-fucopentaose III (LNFPIII) is an immunomodulatory glycan that contains the Lewis X (LeX) trisaccharide.[1][2] It is known to induce an anti-inflammatory or "alternatively activated" phenotype in macrophages.[1][2] Understanding the mechanism of LNFPIII is crucial for designing and interpreting your experiments correctly.

LNFPIII Signaling and Macrophage Activation

LNFPIII interacts with pattern recognition receptors (PRRs) on the surface of macrophages, including Toll-like receptor 4 (TLR4) and various C-type lectin receptors (CLRs) like DC-SIGN.[3][4][5] This interaction initiates a signaling cascade that leads to the alternative activation of macrophages, characterized by the upregulation of specific markers and the production of anti-inflammatory cytokines.[1][2][6]

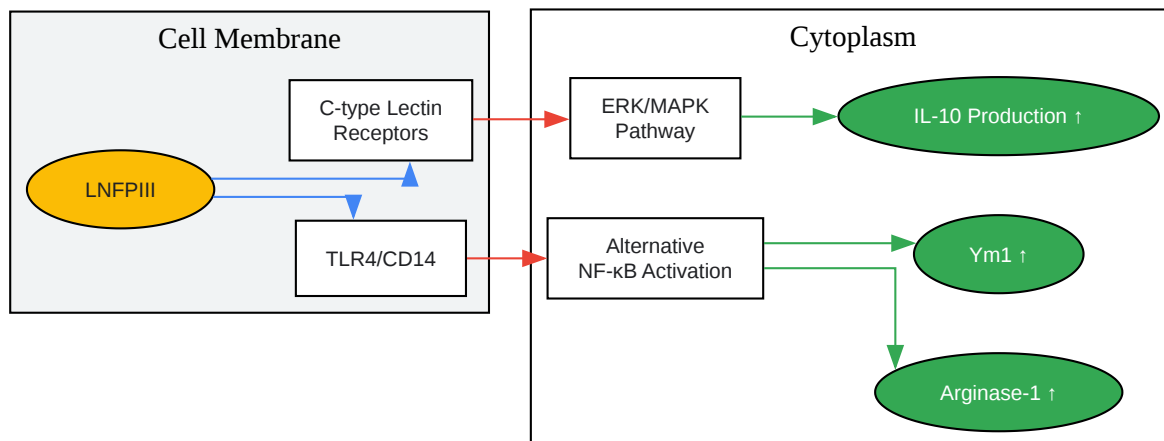

[Click to download full resolution via product page](#)

Caption: LNFPIII signaling cascade in macrophages.

II. Troubleshooting Guide: A Proactive Approach

This section addresses specific issues you may encounter during your experiments, providing explanations and actionable solutions.

Issue 1: Inconsistent or No Macrophage Activation

Question: I've treated my macrophages with LNFPIII, but I'm not observing the expected alternative activation markers. What could be wrong?

Answer: This is a common issue that can stem from several factors, ranging from the LNFPIII concentration to the state of your cells.

Causality and Solutions:

- **Suboptimal LNFPIII Concentration:** The dose-response to LNFPIII can be cell-type specific. A concentration that is too low may not elicit a response, while a concentration that is too high could lead to non-specific effects or even cellular stress.

- Solution: Perform a dose-response experiment to determine the optimal concentration for your specific macrophage type (e.g., bone marrow-derived macrophages (BMDMs), peritoneal macrophages, or a cell line like RAW 264.7).[3][7]
- LNFPIII Conjugation: LNFPIII is often conjugated to a carrier molecule like dextran or bovine serum albumin (BSA) to enhance its immunomodulatory effects.[4][8] The carrier itself can influence cellular responses.
 - Solution: Always include a vehicle control (the carrier molecule alone) in your experiments to distinguish the effects of LNFPIII from those of the carrier.[4]
- Cell Health and Density: Unhealthy or overly confluent cells may not respond appropriately to stimuli.
 - Solution: Ensure your macrophages are healthy, viable, and seeded at an appropriate density.[9] Regularly check for signs of stress or overgrowth.
- Timing of Analysis: The expression of activation markers is a dynamic process. Key markers of alternative activation, such as Arginase-1 and Ym1, are significantly upregulated 20 to 48 hours after LNFPIII exposure in vivo.[1][2]
 - Solution: Perform a time-course experiment to identify the peak expression of your markers of interest.

Issue 2: High Background or Non-Specific Activation in Control Groups

Question: My vehicle control group is showing signs of macrophage activation. How can I reduce this background?

Answer: High background can mask the specific effects of LNFPIII, making data interpretation difficult.

Causality and Solutions:

- Endotoxin Contamination: LNFPIII preparations can sometimes be contaminated with endotoxin (lipopolysaccharide or LPS), a potent activator of classical macrophage activation.

- Solution: Use low-endotoxin LNFPIII preparations and test your reagents for endotoxin levels.[10] Including a polymyxin B control can help determine if endotoxin contamination is a factor.[11]
- Serum in Culture Media: Components in fetal bovine serum (FBS) can sometimes activate macrophages.
 - Solution: Consider using serum-free media or a xeno-free serum replacement for your assays to reduce variability.[12] If using FBS, screen different lots to find one with low background activation.
- Carrier Molecule Effects: The carrier molecule (e.g., dextran) can sometimes have mild, intrinsic effects on macrophages.
 - Solution: As mentioned previously, the vehicle control is critical. If the carrier itself induces significant activation, consider using a different conjugation strategy or a lower concentration.

III. Frequently Asked Questions (FAQs)

General Questions

Q1: What is the recommended starting concentration range for LNFPIII in macrophage assays?

A1: Based on published literature, a starting concentration range of 25-50 µg/mL is recommended for in vitro macrophage assays.[3][4][13][7][11] However, it is crucial to perform a dose-response curve to determine the optimal concentration for your specific experimental setup.

Q2: What are the key markers to assess LNFPIII-induced alternative macrophage activation?

A2: Key markers for LNFPIII-induced alternative activation include the upregulation of Arginase-1 and Ym1.[1][2] Unlike classical M2 activation induced by IL-4/IL-13, LNFPIII does not typically upregulate FIZZ-1, MGL-1, or the mannose receptor (MMR).[1][2] It's also beneficial to measure the production of anti-inflammatory cytokines like IL-10.[1][6][14]

Marker Type	Primary Markers	Secondary Markers
Gene/Protein Expression	Arginase-1 (Arg-1), Ym1 (Chi3I3)	PD-L1, CD80
Cytokine Production	IL-10, TGF- β	IL-13, IL-4 (less consistent)

Experimental Design and Controls

Q3: What are the essential controls for an LNFPIII macrophage assay?

A3: A well-designed experiment should include the following controls:

- Untreated Control: Macrophages in media alone to establish a baseline.
- Vehicle Control: Macrophages treated with the carrier molecule (e.g., dextran) at the same concentration as the LNFPIII-conjugate.
- Positive Control (Alternative Activation): Macrophages treated with IL-4 and/or IL-13 to induce a classical M2 phenotype.[\[15\]](#)[\[16\]](#)
- Positive Control (Classical Activation): Macrophages treated with LPS and/or IFN- γ to induce an M1 phenotype.[\[17\]](#)[\[18\]](#)

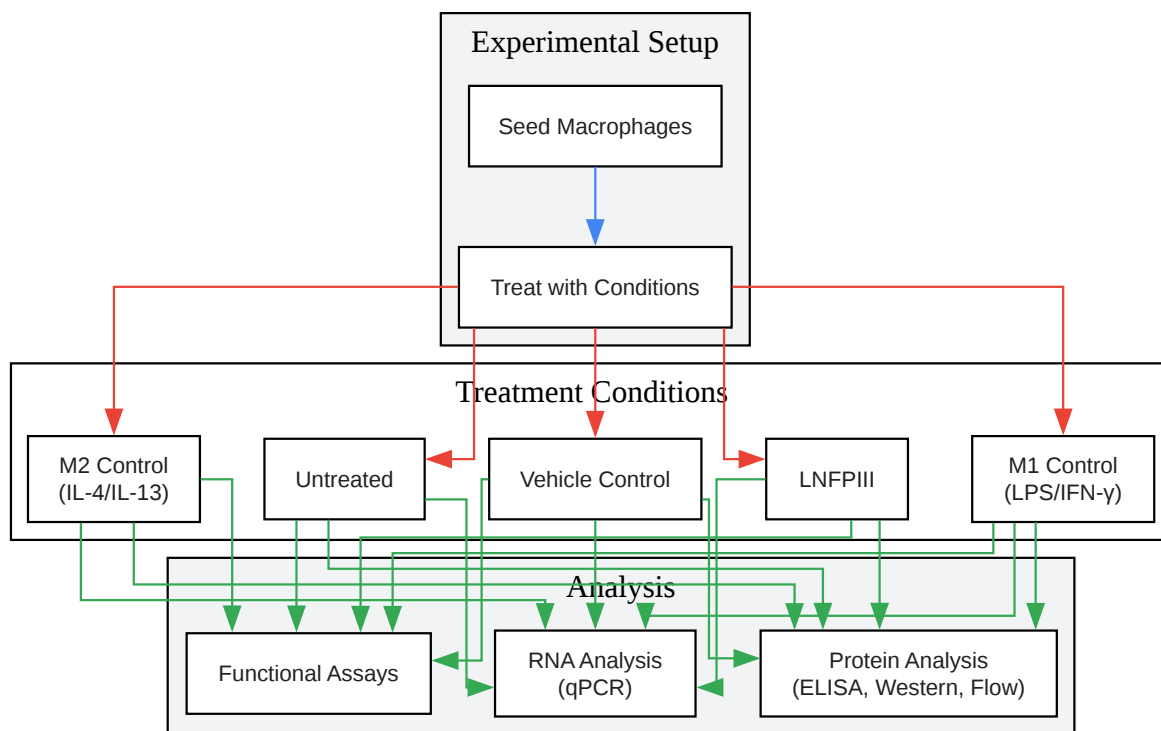

[Click to download full resolution via product page](#)

Caption: Recommended experimental workflow.

Q4: Can I use LNFPIII in co-culture experiments with other cell types?

A4: Yes, LNFPIII-activated macrophages can be used in co-culture experiments. For example, they have been shown to modulate T-cell responses and activate natural killer (NK) cells.[1][11][19] When designing these experiments, it's important to consider that LNFPIII may also have direct effects on the other cell types in your co-culture.

IV. Detailed Experimental Protocols

Protocol 1: Determining Optimal LNFPIII Concentration

- Cell Seeding: Seed macrophages (e.g., BMDMs) in a 96-well plate at a density of 0.1×10^6 cells/well and allow them to adhere overnight.[9]

- LNFPIII Preparation: Prepare a serial dilution of LNFPIII (and a corresponding dilution of the vehicle control) in your culture medium. A suggested range is 0, 1, 5, 10, 25, 50, and 100 $\mu\text{g}/\text{mL}$.
- Treatment: Remove the old medium and add the LNFPIII or vehicle control dilutions to the respective wells.
- Incubation: Incubate the plate for 24-48 hours at 37°C and 5% CO₂.
- Analysis:
 - RNA: Lyse the cells and perform qRT-PCR to measure the gene expression of Arg1 and Ym1.
 - Protein: Collect the supernatant to measure IL-10 levels by ELISA.
- Data Interpretation: Plot the marker expression/concentration against the LNFPIII concentration to determine the optimal dose.

Protocol 2: Assessing Macrophage Activation

- Cell Seeding and Treatment: Seed macrophages as described above and treat with the predetermined optimal concentration of LNFPIII, vehicle control, M1, and M2 stimuli.
- Incubation: Incubate for the optimal duration determined from your time-course experiments (typically 24-48 hours).
- Analysis:
 - qRT-PCR: Analyze the gene expression of Arg1, Ym1, Nos2 (an M1 marker), and a housekeeping gene.
 - ELISA: Measure the concentration of IL-10, TGF- β , and TNF- α (an M1 cytokine) in the culture supernatant.
 - Flow Cytometry: Stain for surface markers such as CD80, PD-L1, and CD206 (an M2 marker) to assess changes in cell surface phenotype.[\[15\]](#)

- Functional Assays: Conduct phagocytosis assays or co-culture experiments to assess the functional consequences of LNFPIII-induced activation.[\[9\]](#)[\[20\]](#)

V. References

- Atochina, O., et al. (2008). The immunomodulatory glycan LNFPIII initiates alternative activation of murine macrophages in vivo. *Immunology*, 125(1), 111-122. [\[Link\]](#)
- Atochina, O., et al. (2005). LNFPIII/LeX-Stimulated Macrophages Activate Natural Killer Cells via CD40-CD40L Interaction. *Clinical and Vaccine Immunology*, 12(9), 1041-1049. [\[Link\]](#)
- Srivastava, L., et al. (2014). Immunomodulatory Glycan **Lacto-N-Fucopentaose III** Requires Clathrin-Mediated Endocytosis To Induce Alternative Activation of Antigen-Presenting Cells. *Infection and Immunity*, 82(11), 4675-4684. [\[Link\]](#)
- Atochina, O., et al. (2005). LNFPIII/LeX-stimulated macrophages activate natural killer cells via CD40-CD40L interaction. *PubMed*, 16148169. [\[Link\]](#)
- Atochina, O., et al. (2008). The immunomodulatory glycan LNFPIII initiates alternative activation of murine macrophages in vivo. *PubMed*, 18373667. [\[Link\]](#)
- Tundup, S., et al. (2015). A Neoglycoconjugate Containing the Human Milk Sugar LNFPIII Drives Anti-Inflammatory Activation of Antigen Presenting Cells in a CD14 Dependent Pathway. *PubMed*, 26339891. [\[Link\]](#)
- Bhargava, P., et al. (2012). Immunomodulatory glycan LNFPIII alleviates hepatosteatosis and insulin resistance through direct and indirect control of metabolic pathways. *Nature Medicine*, 18(11), 1665-1672. [\[Link\]](#)
- Zhu, J., et al. (2012). Immune modulation by **Lacto-N-fucopentaose III** in experimental autoimmune encephalomyelitis. *Journal of Neuroimmunology*, 251(1-2), 33-42. [\[Link\]](#)
- Byrareddy, S. N., et al. (2025). The Human Milk Oligosaccharide **Lacto-N-Fucopentaose III** Conjugated to Dextran Inhibits HIV Replication in Primary Human Macrophages. *MDPI*. [\[Link\]](#)

- Tundup, S., et al. (2015). A Neoglycoconjugate Containing the Human Milk Sugar LNFP III Drives Anti-Inflammatory Activation of Antigen Presenting Cells in a CD14 Dependent Pathway. PLOS One. [[Link](#)]
- He, Y., et al. (2018). Human milk oligosaccharides and its acid hydrolysate LNT2 show immunomodulatory effects via TLRs in a dose and structure. Food & Function, 9(12), 6336-6345. [[Link](#)]
- Tundup, S., et al. (2015). A Neoglycoconjugate Containing the Human Milk Sugar LNFP III Drives Anti-Inflammatory Activation of Antigen Presenting Cells in a. Semantic Scholar. [[Link](#)]
- Bhargava, P., et al. (2012). Immunomodulatory glycan LNFP III alleviates hepatosteatosis and insulin resistance through direct and indirect control of metabolic pathways. PubMed, 23104131. [[Link](#)]
- Srivastava, L., et al. (2014). Immunomodulatory Glycan **Lacto-N-Fucopentaose III** Requires Clathrin-Mediated Endocytosis To Induce Alternative Activation of Antigen-Presenting Cells. ASM Journals. [[Link](#)]
- Lonza (n.d.). Macrophage Polarization and Phagocytosis Assay - Instruction for use. Lonza. [[Link](#)]
- Srivastava, L., et al. (2014). Endocytosis of LNFP III-NGC is dynamin mediated. ResearchGate. [[Link](#)]
- Vogel, D. Y., et al. (2015). A Systematic Approach to Identify Markers of Distinctly Activated Human Macrophages. Frontiers in Immunology, 6, 263. [[Link](#)]
- The Regeneration Center (2023). Macrophage Markers Function and Activation. The Regeneration Center. [[Link](#)]
- Atochina, O., et al. (2005). LNFP III/LeX-Stimulated Macrophages Activate Natural Killer Cells via CD40-CD40L Interaction. ASM Journals. [[Link](#)]
- Sartorius (n.d.). Technical Note - Optimise your Macrophage Assays and Boost your Immunology Research. Sartorius. [[Link](#)]

- Sharma, N., et al. (2022). In Vitro Screening Method for Characterization of Macrophage Activation Responses. MDPI. [[Link](#)]
- Yang, Z., et al. (2013). Macrophages as IL-25/IL-33-Responsive Cells Play an Important Role in the Induction of Type 2 Immunity. PLOS ONE, 8(3), e59441. [[Link](#)]
- Rodriguez Benavente, A., et al. (2024). One N-glycan regulates natural killer cell antibody-dependent cell-mediated cytotoxicity and modulates Fc γ receptor IIIa/CD16a structure. eLife. [[Link](#)]
- The Scientist (n.d.). Optimizing In Vitro Production of Monocyte-Derived Dendritic Cells and Macrophages. The Scientist. [[Link](#)]

Need Custom Synthesis?

BenchChem offers custom synthesis for rare earth carbides and specific isotopic labeling.

Email: info@benchchem.com or [Request Quote Online](#).

Sources

- 1. The immunomodulatory glycan LNFPIII initiates alternative activation of murine macrophages in vivo - PMC [[pmc.ncbi.nlm.nih.gov](https://pubmed.ncbi.nlm.nih.gov/)]
- 2. The immunomodulatory glycan LNFPIII initiates alternative activation of murine macrophages in vivo [pubmed.ncbi.nlm.nih.gov]
- 3. Immunomodulatory Glycan Lacto-N-Fucopentaose III Requires Clathrin-Mediated Endocytosis To Induce Alternative Activation of Antigen-Presenting Cells - PMC [[pmc.ncbi.nlm.nih.gov](https://pubmed.ncbi.nlm.nih.gov/)]
- 4. Immune modulation by Lacto-N-fucopentaose III in experimental autoimmune encephalomyelitis - PMC [[pmc.ncbi.nlm.nih.gov](https://pubmed.ncbi.nlm.nih.gov/)]
- 5. rug.nl [rug.nl]
- 6. Immunomodulatory glycan LNFPIII alleviates hepatosteatosis and insulin resistance through direct and indirect control of metabolic pathways - PMC [[pmc.ncbi.nlm.nih.gov](https://pubmed.ncbi.nlm.nih.gov/)]
- 7. journals.asm.org [journals.asm.org]
- 8. mdpi.com [mdpi.com]

- [9. lonzabio.jp \[lonzabio.jp\]](#)
- [10. journals.asm.org \[journals.asm.org\]](#)
- [11. LNFPIII/LeX-Stimulated Macrophages Activate Natural Killer Cells via CD40-CD40L Interaction - PMC \[pmc.ncbi.nlm.nih.gov\]](#)
- [12. Optimizing In Vitro Production of Monocyte-Derived Dendritic Cells and Macrophages | The Scientist \[the-scientist.com\]](#)
- [13. pdfs.semanticscholar.org \[pdfs.semanticscholar.org\]](#)
- [14. Immunomodulatory glycan LNFPIII alleviates hepatosteatosis and insulin resistance through direct and indirect control of metabolic pathways - PubMed \[pubmed.ncbi.nlm.nih.gov\]](#)
- [15. stemcellthailand.org \[stemcellthailand.org\]](#)
- [16. Macrophages as IL-25/IL-33-Responsive Cells Play an Important Role in the Induction of Type 2 Immunity | PLOS One \[journals.plos.org\]](#)
- [17. Frontiers | A Systematic Approach to Identify Markers of Distinctly Activated Human Macrophages \[frontiersin.org\]](#)
- [18. mdpi.com \[mdpi.com\]](#)
- [19. LNFPIII/LeX-stimulated macrophages activate natural killer cells via CD40-CD40L interaction - PubMed \[pubmed.ncbi.nlm.nih.gov\]](#)
- [20. info.edifydigitalmedia.com \[info.edifydigitalmedia.com\]](#)
- To cite this document: BenchChem. [Technical Support Center: Optimizing LNFPIII Concentration for Macrophage Assays]. BenchChem, [2026]. [Online PDF]. Available at: [<https://www.benchchem.com/product/b7803940/docs#technical-support-center-optimizing-lnfpiii-concentration-for-macrophage-assays>]

Disclaimer & Data Validity:

The information provided in this document is for Research Use Only (RUO) and is strictly not intended for diagnostic or therapeutic procedures. While BenchChem strives to provide accurate protocols, we make no warranties, express or implied, regarding the fitness of this product for every specific experimental setup.

Technical Support: The protocols provided are for reference purposes. Unsure if this reagent suits your experiment?

Need Industrial/Bulk Grade? [Request Custom Synthesis Quote](#)

BenchChem

Our mission is to be the trusted global source of essential and advanced chemicals, empowering scientists and researchers to drive progress in science and industry.

Contact

Address: 3281 E Guasti Rd
Ontario, CA 91761, United States
Phone: (601) 213-4426
Email: info@benchchem.com

[Contact our Ph.D. Support Team for a compatibility check](#)