

Technical Support Center: Troubleshooting Calibration Curve Linearity in 6-Hydroxyestriol Quantification

Author: BenchChem Technical Support Team. **Date:** May 2026

Compound of Interest

Compound Name: 6-Hydroxyestriol

CAS No.: 14507-00-7

Cat. No.: B078679

[Get Quote](#)

Welcome to the technical support center for the quantification of **6-hydroxyestriol** (6-OH-E3). This guide is designed for researchers, scientists, and drug development professionals to diagnose and resolve common issues related to calibration curve linearity. Accurate quantification of 6-OH-E3, a key estrogen metabolite, is paramount in many areas of clinical and pharmaceutical research. A robust and linear calibration curve is the cornerstone of reliable data. This document provides in-depth, experience-driven troubleshooting advice in a direct question-and-answer format.

Part 1: Frequently Asked Questions (FAQs)

This section addresses common high-level questions regarding calibration curve linearity.

Q1: What is calibration curve linearity, and why is it critical for **6-hydroxyestriol** quantification?

A1: Linearity describes the ability of an analytical method to produce results that are directly proportional to the concentration of the analyte (in this case, 6-OH-E3) within a given range.[1]
[2] A linear relationship, typically represented by the equation $y = mx + b$, ensures that as the

concentration of 6-OH-E3 changes, the instrument's response changes predictably. This is critical because the concentration of an unknown sample is calculated by interpolating its response from this curve. Any deviation from linearity will lead to inaccurate quantification.[3]

Q2: What are the typical regulatory acceptance criteria for linearity?

A2: Regulatory bodies like the U.S. Food and Drug Administration (FDA) and the European Medicines Agency (EMA) provide guidelines for bioanalytical method validation.[4][5][6][7] While they don't always mandate a specific correlation coefficient, the general expectation for chromatographic assays is a correlation coefficient (r) of ≥ 0.99 or a coefficient of determination (r^2) of ≥ 0.98 . More importantly, the back-calculated concentrations of the calibration standards must meet predefined accuracy criteria.

Parameter	FDA[7][8]	EMA[4][5]
Calibration Points	Minimum of 6 non-zero standards	A blank, a zero, and at least 6 calibrants
Correlation Coefficient (r)	Not explicitly defined, focus on accuracy	Not explicitly defined, focus on accuracy
Accuracy of Back-Calculated Standards	$\pm 15\%$ of nominal value	$\pm 15\%$ of nominal value
Accuracy at LLOQ	$\pm 20\%$ of nominal value	$\pm 20\%$ of nominal value
Run Acceptance	At least 75% of non-zero standards must meet accuracy criteria	At least 75% of calibrants must meet accuracy criteria

Q3: What are the most common causes of non-linearity in steroid hormone assays like 6-OH-E3?

A3: Non-linearity in LC-MS/MS or GC-MS assays for steroids often stems from several sources. These include detector saturation at high concentrations, matrix effects from biological samples like plasma or urine, issues with the internal standard, suboptimal ionization in the mass spectrometer source, or simply errors in the preparation of standard solutions.[3][9][10][11][12]

Q4: Should I use a linear or a quadratic fit for my calibration curve?

A4: The simplest model that adequately describes the concentration-response relationship should be used. A linear regression is strongly preferred. However, if the response is consistently and reproducibly non-linear, a quadratic (second-order polynomial) regression may be justified.^{[11][13]} The use of a quadratic fit must be pre-specified in the method validation plan and rigorously evaluated to ensure it provides a better fit than a linear model without masking underlying analytical problems.^[13]

Q5: What is the purpose of using a weighted regression model (e.g., $1/x$ or $1/x^2$)?

A5: Bioanalytical data often exhibit heteroscedasticity, meaning the variability of the data is not constant across the concentration range.^{[14][15]} Typically, the absolute error is larger at higher concentrations. An unweighted (Ordinary Least Squares, OLS) regression gives equal importance to all points, meaning the high-concentration points with larger variance can disproportionately influence the curve fit, leading to significant inaccuracy at the lower limit of quantification (LLOQ).^{[15][16]} Weighted least squares (WLS) regression applies a weighting factor (commonly $1/x$ or $1/x^2$) to give more weight to the lower-concentration, less variable points, resulting in a more accurate and robust model across the entire range.^{[14][15][16][17][18]}

Part 2: In-Depth Troubleshooting Guide

This section provides detailed troubleshooting for specific linearity problems you may encounter.

Problem 1: My correlation coefficient (r^2) is consistently below the required limit (e.g., <0.99). What should I investigate?

A low correlation coefficient indicates a poor fit of the regression line to the data points, suggesting random error or a systematic deviation from linearity.

Causality: The entire calibration curve is built upon the accuracy of the calibrator concentrations. Errors in serial dilutions, incorrect stock concentration, or degradation of the analyte will directly translate to scattered or biased data points.^{[9][19]}

Troubleshooting Protocol:

- Prepare a Fresh Stock Solution: Use a newly weighed, high-purity reference standard of **6-hydroxyestriol**. Verify the purity from the certificate of analysis.
- Use Calibrated Equipment: Ensure all pipettes and volumetric flasks are properly calibrated and used correctly. For stock solutions, use volumetric flasks; for serial dilutions, use calibrated positive displacement or air displacement pipettes.
- Perform Sanity Check: Prepare a mid-range Quality Control (QC) sample from a separate stock solution weighing. The concentration of this independent QC, when calculated against the new curve, should be within $\pm 15\%$ of its nominal value.
- Evaluate Solvent: Ensure the solvent used for standards is of high purity and does not cause degradation. 6-OH-E3 is a steroid and may have limited solubility in highly aqueous solutions. A solvent composition similar to the initial mobile phase is often a good choice.[\[19\]](#)

Causality: An internal standard is added to correct for variability during sample processing and analysis.[\[20\]](#)[\[21\]](#) An ideal IS behaves identically to the analyte. If the IS response is erratic or does not track with the analyte (e.g., it experiences different matrix effects), the analyte-to-IS response ratio will be inconsistent, leading to poor linearity.[\[20\]](#) For 6-OH-E3, a stable isotope-labeled (SIL) version, such as **6-hydroxyestriol-d3**, is the gold standard as its physicochemical properties are nearly identical to the analyte.[\[20\]](#)[\[22\]](#)[\[23\]](#)

Troubleshooting Protocol:

- Verify IS Purity and Concentration: Ensure the IS stock solution is accurate. Contamination of the IS with unlabeled analyte can compromise the assay, especially at the LLOQ.[\[21\]](#)
- Monitor Absolute IS Response: Plot the absolute peak area of the IS for each calibrator. The response should be consistent across all points. A significant trend (e.g., decreasing IS response with increasing analyte concentration) may indicate that the analyte is suppressing the IS ionization.
- Assess IS Suitability: If not using a SIL-IS, ensure your structural analog co-elutes with 6-OH-E3 and shows similar ionization behavior.[\[22\]](#) A post-column infusion experiment (see

Problem 2, Cause B) can be used to verify that both the analyte and the IS are affected similarly by matrix components.

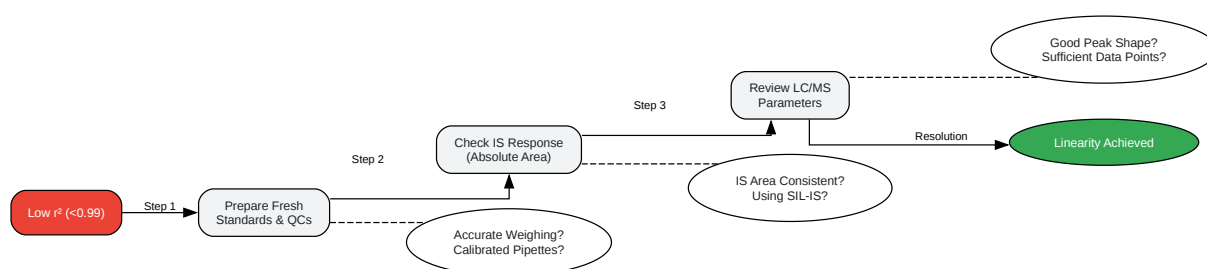

[Click to download full resolution via product page](#)

Caption: Systematic workflow for diagnosing a low correlation coefficient.

Problem 2: My curve is consistently bending at the high concentration end (saturation effect). What's happening?

This is a classic sign of a non-linear response where the signal is no longer proportional to the concentration at the upper end of the curve.

Causality: Every mass spectrometer detector has a finite linear dynamic range. When an excessively high concentration of ions hits the detector simultaneously, it becomes saturated and can no longer produce a proportional signal, leading to a plateauing of the response.[11][12][13] This is a very common cause of non-linearity at the ULOQ.

Troubleshooting Protocol:

- Examine Peak Shape: In the chromatogram of your highest standard (ULOQ), check if the peak is flat-topped or "clipped." This is a definitive sign of detector saturation.[24]

- Dilute the ULOQ: Prepare a 1:2 or 1:5 dilution of the ULOQ standard and analyze it. If the back-calculated concentration (after correcting for dilution) is now accurate, it strongly suggests detector saturation was the issue with the undiluted sample.
- Reduce Signal Intensity: To fix this, you can:
 - Lower the injection volume.
 - Dilute the sample before injection.
 - Select a less abundant (but still specific) MS/MS transition for quantification.
 - Adjust instrument parameters (e.g., reduce detector gain/voltage), though this may impact sensitivity at the LLOQ.
- Re-define the ULOQ: The simplest solution is often to lower the ULOQ to a concentration that falls within the detector's linear range.

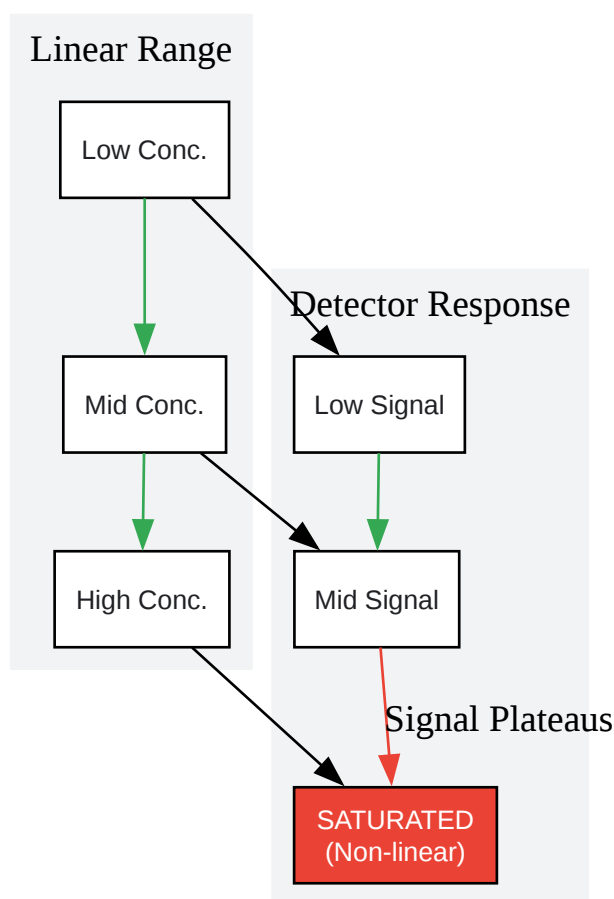

[Click to download full resolution via product page](#)

Caption: Conceptual diagram of detector saturation.

Causality: Matrix effect is the alteration of ionization efficiency by co-eluting compounds from the biological matrix (e.g., phospholipids, salts).[3][25][26][27][28] At high analyte concentrations, the matrix effect may become non-linear or the IS may not be able to compensate for it adequately, causing the curve to bend.[3][29]

Troubleshooting Protocol:

- Perform a Post-Column Infusion Experiment: This is the definitive test for matrix effects.
 - Setup: Infuse a constant concentration of 6-OH-E3 and its IS into the MS source post-column using a syringe pump and a T-junction.
 - Analysis: Inject a blank, extracted matrix sample onto the LC column.
 - Interpretation: Monitor the signal of the infused analyte. Any dip or rise in the signal at specific retention times indicates ion suppression or enhancement, respectively, from co-eluting matrix components.
- Improve Chromatography: Adjust the LC gradient to separate 6-OH-E3 from the regions of ion suppression identified in the post-column infusion experiment.
- Enhance Sample Cleanup: Use a more rigorous sample preparation technique (e.g., switch from protein precipitation to solid-phase extraction (SPE) or liquid-liquid extraction (LLE)) to remove interfering matrix components.[26][27]

Problem 3: My curve shows high variability and/or inaccuracy at the low concentration end (LLOQ). How can I fix this?

Inaccuracy at the LLOQ is a common challenge and is often related to poor signal-to-noise or incorrect regression modeling.

Causality: The LLOQ must be reliably and reproducibly distinguishable from the background noise. If the signal is too low (typically $S/N < 10$), the integration of the peak area becomes inconsistent, leading to high variability (%CV) and poor accuracy (%RE).

Troubleshooting Protocol:

- Optimize MS/MS Parameters: Tune the instrument specifically for 6-OH-E3. Optimize collision energy, source temperatures, and gas flows to maximize the signal for your specific quantifier/qualifier transitions.
- Improve Sample Preparation: Increase the concentration factor of your sample prep. For example, extract a larger volume of plasma and reconstitute in a smaller volume of solvent.
- Reduce System Noise: Ensure the LC-MS system is clean. Flush the system, clean the MS source, and use high-purity solvents and additives to reduce chemical background noise.

Causality: As mentioned in the FAQs, most bioanalytical data is heteroscedastic. Using a simple linear regression (unweighted) allows the high-concentration standards, which have a much larger absolute response, to dominate the regression fit. This often results in the regression line passing above or below the LLOQ and low-concentration points, causing significant bias.

Troubleshooting Protocol:

- Analyze the Residuals: Plot the percentage relative error (%RE) for each calibrator against its concentration. A "funnel" or "megaphone" shape, where the error is much larger at the LLOQ and decreases with concentration, is a clear sign of heteroscedasticity.
- Apply a Weighting Factor: Re-process your data using a weighted least squares (WLS) regression. The most common and effective weighting factors for LC-MS data are $1/x$ or $1/x^2$.
- Compare the Models: Evaluate the %RE for all calibrators using both the unweighted and weighted models. The best model is the one that minimizes the sum of the absolute %RE values across the entire curve, providing the best accuracy at all levels.

Concentration (ng/mL)	Response Ratio (y)	%RE (Unweighted)	%RE (1/x ² Weighted)
1 (LLOQ)	0.012	-18.5%	-2.1%
2	0.025	-11.2%	+1.5%
5	0.060	-5.4%	+0.8%
50	0.580	+1.1%	-0.6%
250	2.95	+2.3%	+1.2%
500 (ULOQ)	5.70	-0.5%	-0.9%

As shown in the table, the 1/x² weighted model provides significantly better accuracy at the critical low end of the curve.

References

- European Medicines Agency. (2011). Guideline on bioanalytical method validation. EMEA/CHMP/EWP/192217/2009 Rev. 1 Corr. 2**. [\[Link\]](#)
- European Medicines Agency. (2022). Bioanalytical method validation and study sample analysis (ICH M10). [\[Link\]](#)
- European Bioanalysis Forum. (2012). The EMA Bioanalytical Method Validation Guideline: process, history, discussions and evaluation of its content. [\[Link\]](#)
- European Medicines Agency. (2009). Draft Guideline on bioanalytical method validation. EMEA/CHMP/EWP/192217/2009. [\[Link\]](#)
- Restek Corporation. (n.d.). Gas Chromatography Problem Solving and Troubleshooting. [\[Link\]](#)
- Sharma, G. (2014). Bioanalytical method validation emea. SlideShare. [\[Link\]](#)
- Hinshaw, J. V. (2014). Non-linear Calibration. LCGC Europe. [\[Link\]](#)

- Zhang, D., et al. (2015). Systematic evaluation of the root cause of non-linearity in liquid chromatography/tandem mass spectrometry bioanalytical assays and strategy to predict and extend the linear standard curve range. *Journal of Chromatography B*, 997, 209-216. [[Link](#)]
- Reddit. (2023). I'm getting non-linear response. *r/CHROMATOGRAPHY*. [[Link](#)]
- U.S. Food and Drug Administration. (2022). M10 Bioanalytical Method Validation and Study Sample Analysis Guidance for Industry. [[Link](#)]
- Asuero, A. G., & Sayago, A. (2017). Fitting Nonlinear Calibration Curves: No Models Perfect. *American Journal of Analytical Chemistry*, 8(11), 727-753. [[Link](#)]
- ResolveMass Laboratories Inc. (2023). Essential FDA Guidelines for Bioanalytical Method Validation. [[Link](#)]
- Sandle, T. (2023). FDA Adopts ICH Final Guidance On Bioanalytical Method Validation. *Outsourced Pharma*. [[Link](#)]
- U.S. Food and Drug Administration. (2018). Bioanalytical Method Validation Guidance for Industry. [[Link](#)]
- Zaiontz, C. (n.d.). WLS regression and heteroskedasticity. *Real Statistics Using Excel*. [[Link](#)]
- Li, H., et al. (2012). Matrix effects break the LC behavior rule for analytes in LC-MS/MS analysis of biological samples. *Journal of Analytical & Bioanalytical Techniques*, 3(4). [[Link](#)]
- Regulations.gov. (2013). FDA Draft Guidance for Industry - Bioanalytical Method Validation. [[Link](#)]
- Zilfimian, L. (2020). Solving the problem of heteroscedasticity through weighted regression. *Medium*. [[Link](#)]
- Van Acker, T., et al. (2021). Weighted Linear Regression Improves Accuracy of Quantitative Elemental Bioimaging by Means of LA-ICP-MS. *Analytical Chemistry*, 93(47), 15720-15727. [[Link](#)]

- Ganesalingam, J., & Kaskhedikar, S. (2013). Strategies for the Detection and Elimination of Matrix Effects in Quantitative LC–MS Analysis. *Chromatography Today*. [[Link](#)]
- Ganiyu, S. A., & Oladugba, A. V. (2024). Enhanced weighted least squares regression: A robust approach for managing outliers and heteroscedasticity. *Scientific Research Archives*, 5(1), 1-14. [[Link](#)]
- Cheng, W. L., et al. (2023). Calibration Practices in Clinical Mass Spectrometry: Review and Recommendations. *Annals of Laboratory Medicine*, 43(1), 5-18. [[Link](#)]
- Minitab. (2012). Curing Heteroscedasticity with Weighted Regression in Minitab Statistical Software. [[Link](#)]
- Cheng, W. L., et al. (2023). Calibration Practices in Clinical Mass Spectrometry: Review and Recommendations. CABI Digital Library. [[Link](#)]
- University of Tartu. (n.d.). 3.1. Linearity – Validation of liquid chromatography mass spectrometry (LC-MS) methods. [[Link](#)]
- Spáčil, Z., et al. (2016). Evaluation of Matrix Effects and Extraction Efficiencies of LC–MS/MS Methods as the Essential Part for Proper Validation of Multiclass Contaminants in Complex Feed. *Journal of Agricultural and Food Chemistry*, 64(29), 5945-5954. [[Link](#)]
- Jian, W., et al. (2014). Assessment of matrix effect in quantitative LC-MS bioanalysis. *Bioanalysis*, 6(19), 2563-2566. [[Link](#)]
- NorthEast BioLab. (2024). Best Practices for Calibration Curves in LC-MS/MS: Ensuring Accuracy and Reliability. [[Link](#)]
- SCIEX. (2022). A Sensitive and Specific ESI-Positive LC–MS/MS Method for the Quantitation of Estrogens in Human Serum in Under Three Minutes. [[Link](#)]
- ResearchGate. (2018). What is causing the problem for unreproducible callibration curves within LC-MS/MS?. [[Link](#)]
- Dolan, J. W. (2024). Matrix Effects on Quantitation in Liquid Chromatography: Sources and Solutions. LCGC International. [[Link](#)]

- Dolan, J. W. (2012). When Should an Internal Standard be Used?. LCGC International. [[Link](#)]
- Kushnir, M. M., et al. (2018). Current strategies for quantification of estrogens in clinical research. *Steroids*, 133, 44-54. [[Link](#)]
- Hossain, M. M., et al. (2015). Linearity study on detection and quantification limits for the determination of avermectins using linear regression. *Journal of Food and Drug Analysis*, 23(3), 476-484. [[Link](#)]
- ResearchGate. (2020). Linearity and sensitivity of the developed methods (n=6). [[Link](#)]

Need Custom Synthesis?

BenchChem offers custom synthesis for rare earth carbides and specific isotopic labeling.

Email: info@benchchem.com or [Request Quote Online](#).

Sources

- 1. FDA Adopts ICH Final Guidance On Bioanalytical Method Validation [outsourcedpharma.com]
- 2. Linearity study on detection and quantification limits for the determination of avermectins using linear regression - PMC [pubmed.ncbi.nlm.nih.gov]
- 3. 3.1. Linearity – Validation of liquid chromatography mass spectrometry (LC-MS) methods [sisu.ut.ee]
- 4. ema.europa.eu [ema.europa.eu]
- 5. Bioanalytical method validation - Scientific guideline | European Medicines Agency (EMA) [ema.europa.eu]
- 6. fda.gov [fda.gov]
- 7. fda.gov [fda.gov]
- 8. resolvemass.ca [resolvemass.ca]
- 9. academic.oup.com [academic.oup.com]
- 10. alfresco-static-files.s3.amazonaws.com [alfresco-static-files.s3.amazonaws.com]
- 11. Calibration Practices in Clinical Mass Spectrometry: Review and Recommendations - PMC [pubmed.ncbi.nlm.nih.gov]

- [12. cabidigitallibrary.org \[cabidigitallibrary.org\]](https://cabidigitallibrary.org)
- [13. researchgate.net \[researchgate.net\]](https://researchgate.net)
- [14. WLS and heteroskedasticity | Real Statistics Using Excel \[real-statistics.com\]](https://real-statistics.com)
- [15. Weighted Linear Regression Improves Accuracy of Quantitative Elemental Bioimaging by Means of LA-ICP-MS - PubMed \[pubmed.ncbi.nlm.nih.gov\]](https://pubmed.ncbi.nlm.nih.gov)
- [16. sciresjournals.com \[sciresjournals.com\]](https://sciresjournals.com)
- [17. medium.com \[medium.com\]](https://medium.com)
- [18. blog.minitab.com \[blog.minitab.com\]](https://blog.minitab.com)
- [19. researchgate.net \[researchgate.net\]](https://researchgate.net)
- [20. Internal Standards in LC-MS Bioanalysis: Which, When, and How - WuXi AppTec DMPK \[dmpk.wuxiapptec.com\]](https://dmpk.wuxiapptec.com)
- [21. chromatographyonline.com \[chromatographyonline.com\]](https://chromatographyonline.com)
- [22. pdf.benchchem.com \[pdf.benchchem.com\]](https://pdf.benchchem.com)
- [23. Current strategies for quantification of estrogens in clinical research - PMC \[pmc.ncbi.nlm.nih.gov\]](https://pmc.ncbi.nlm.nih.gov)
- [24. reddit.com \[reddit.com\]](https://reddit.com)
- [25. Matrix effects break the LC behavior rule for analytes in LC-MS/MS analysis of biological samples - PMC \[pmc.ncbi.nlm.nih.gov\]](https://pmc.ncbi.nlm.nih.gov)
- [26. chromatographyonline.com \[chromatographyonline.com\]](https://chromatographyonline.com)
- [27. Assessment of matrix effect in quantitative LC-MS bioanalysis - PMC \[pmc.ncbi.nlm.nih.gov\]](https://pmc.ncbi.nlm.nih.gov)
- [28. infinixbio.com \[infinixbio.com\]](https://infinixbio.com)
- [29. Fitting Nonlinear Calibration Curves: No Models Perfect \[scirp.org\]](https://scirp.org)
- To cite this document: BenchChem. [Technical Support Center: Troubleshooting Calibration Curve Linearity in 6-Hydroxyestriol Quantification]. BenchChem, [2026]. [Online PDF]. Available at: [<https://www.benchchem.com/product/b078679/docs#technical-support-center-troubleshooting-calibration-curve-linearity-in-6-hydroxyestriol-quantification>]

Disclaimer & Data Validity:

The information provided in this document is for Research Use Only (RUO) and is strictly not intended for diagnostic or therapeutic procedures. While BenchChem strives to provide

accurate protocols, we make no warranties, express or implied, regarding the fitness of this product for every specific experimental setup.

Technical Support: The protocols provided are for reference purposes. Unsure if this reagent suits your experiment?

Need Industrial/Bulk Grade? [Request Custom Synthesis Quote](#)

BenchChem

Our mission is to be the trusted global source of essential and advanced chemicals, empowering scientists and researchers to drive progress in science and industry.

Contact

Address: 3281 E Guasti Rd

Ontario, CA 91761, United States

Phone: (601) 213-4426

Email: info@benchchem.com

[Contact our Ph.D. Support Team for a compatibility check](#)