

Technical Support Center: Synthesis of High-Purity 2-Methylpropane-2-d

Author: BenchChem Technical Support Team. **Date:** February 2026

Compound of Interest

Compound Name: 2-Methylpropane-2-d

CAS No.: 13183-68-1

Cat. No.: B078710

[Get Quote](#)

Welcome to the technical support center for the synthesis of high-purity **2-Methylpropane-2-d**, also known as tert-butane-d1. This guide is designed for researchers, medicinal chemists, and process development scientists who require this valuable isotopically labeled compound for applications ranging from mechanistic studies to internal standards in quantitative mass spectrometry.

This document provides in-depth, experience-driven guidance in a practical question-and-answer format. We will explore the nuances of the synthesis, address common challenges, and provide robust protocols to help you achieve high isotopic and chemical purity in your experiments.

Section 1: Foundational FAQs

This section addresses high-level questions about the synthesis and properties of **2-Methylpropane-2-d**.

Q1: What are the primary applications of high-purity **2-Methylpropane-2-d**?

A1: High-purity **2-Methylpropane-2-d** is primarily used in fields that leverage the kinetic isotope effect (KIE) or require a precise mass shift for analytical purposes. Substituting a hydrogen atom with deuterium can alter reaction rates and metabolic pathways, providing crucial insights for drug development.^{[1][2]} Additionally, its use as an internal standard in mass

spectrometry is invaluable for accurately quantifying non-deuterated analogues in complex biological matrices.[3]

Q2: What is the most common and reliable method for synthesizing **2-Methylpropane-2-d**?

A2: The most prevalent and accessible method is the reaction of a tert-butyl Grignard reagent (e.g., tert-butylmagnesium chloride or bromide) with a high-purity deuterium source, typically heavy water (D₂O).[4][5] This organometallic reaction provides a direct and generally high-yielding pathway to introduce a single deuterium atom at the tertiary carbon position.

Q3: What level of isotopic purity is considered "high-purity" for **2-Methylpropane-2-d**?

A3: For most applications, an isotopic purity of ≥ 98 atom % D is considered high quality.[6] This means that in a given sample, at least 98% of the molecules at the target position contain a deuterium atom, while the remaining percentage consists of the protio-isotopologue, 2-Methylpropane ((CH₃)₃CH). The definition of purity must also encompass chemical purity, ensuring the absence of solvents, starting materials, or byproducts.[7]

Section 2: Detailed Experimental Protocol

This section provides a comprehensive, step-by-step protocol for the synthesis of **2-Methylpropane-2-d** via the Grignard reaction. The causality behind critical steps is explained to ensure success.

Protocol: Synthesis of **2-Methylpropane-2-d** via Grignard Reaction with D₂O

This protocol details the formation of tert-butylmagnesium chloride followed by quenching with heavy water.

Step 1: Rigorous Drying of Apparatus and Reagents

- Action: All glassware (three-neck round-bottom flask, reflux condenser, dropping funnel) must be oven-dried at >120 °C for at least 4 hours or flame-dried under a vacuum while assembling. Allow to cool to room temperature under a stream of dry, inert gas (Argon or Nitrogen).[8]

- **Causality & Expertise:** Grignard reagents are extremely potent bases and nucleophiles that react instantaneously and exothermically with protic sources, especially water.[2][5] Even atmospheric moisture or water adsorbed onto the glass surface can quench the reagent, drastically reducing yield. Flame-drying creates a moisture-free surface immediately before use, which is a field-proven technique for ensuring success.

Step 2: Preparation of tert-Butylmagnesium Chloride

- **Action:**
 - To the dry, three-neck flask equipped with a magnetic stir bar, add magnesium turnings (1.2 equivalents).
 - Assemble the glassware under a positive pressure of inert gas.
 - Add a small crystal of iodine. The flask may be gently warmed to sublime the iodine, activating the magnesium surface.
 - In the dropping funnel, prepare a solution of 2-chloro-2-methylpropane (tert-butyl chloride, 1.0 equivalent) in anhydrous diethyl ether or tetrahydrofuran (THF).
 - Add a small portion (~10%) of the tert-butyl chloride solution to the magnesium turnings.
 - Observe for initiation, which is marked by bubble formation and a gentle reflux. If the reaction does not start, gently warm the flask with a heat gun.
 - Once initiated, add the remaining tert-butyl chloride solution dropwise at a rate that maintains a steady reflux.
 - After the addition is complete, continue to stir the mixture at room temperature for 1-2 hours until most of the magnesium has been consumed.
- **Causality & Expertise:** The iodine crystal chemically etches the passivating magnesium oxide (MgO) layer on the turnings, exposing fresh, reactive magnesium metal.[3] The reaction is autocatalytic; once it begins, the heat generated sustains it. A slow, controlled addition of the alkyl halide is critical to prevent a runaway reaction and to minimize the formation of the Wurtz coupling side-product (2,2,3,3-tetramethylbutane).[3]

Step 3: Deuteration (Quenching)

- Action:
 - Cool the Grignard reagent solution to 0 °C using an ice-water bath.
 - Slowly add high-purity D₂O (≥99.8 atom % D, 1.5 equivalents) dropwise via syringe or dropping funnel. This is a highly exothermic reaction; maintain a slow addition rate to keep the internal temperature below 20 °C.
 - After the addition is complete, allow the mixture to warm to room temperature and stir for 30 minutes.
- Causality & Expertise: The Grignard reagent's carbanionic character leads to a vigorous acid-base reaction with D₂O, where the tert-butyl group is deuterated and a magnesium salt byproduct (Mg(OD)Cl) precipitates.^[4] Cooling the reaction is crucial to control the exotherm and prevent excessive ether evaporation. Using an excess of D₂O ensures the complete consumption of the Grignard reagent.

Step 4: Workup and Purification

- Action:
 - The reaction will result in a thick slurry. Cautiously add a saturated aqueous solution of ammonium chloride (NH₄Cl) to dissolve the magnesium salts.
 - Transfer the mixture to a separatory funnel. Separate the organic (ether) layer.
 - Wash the organic layer sequentially with saturated NH₄Cl solution, then with brine (saturated NaCl solution).
 - Dry the organic layer over an anhydrous drying agent (e.g., anhydrous MgSO₄ or Na₂SO₄).
 - Filter to remove the drying agent. The resulting solution contains **2-Methylpropane-2-d** in the solvent.

- Due to the high volatility of the product (boiling point: $-12\text{ }^{\circ}\text{C}$), purification is best achieved by either low-temperature fractional distillation or, for the highest purity, preparative gas chromatography (pGC).[1]
- Causality & Expertise: The NH_4Cl workup is a standard procedure to quench any remaining Grignard reagent and to create a slightly acidic environment that helps dissolve the magnesium salts without using a strong acid, which could promote side reactions.[9][10] Preparative GC is the gold standard for separating volatile isotopologues and impurities that have very similar boiling points, ensuring the highest chemical and isotopic purity.[11]

Section 3: Troubleshooting Guide (Q&A)

This section addresses specific problems you may encounter during the synthesis.

Q4: My Grignard reaction won't start. What should I do?

A4: This is the most common failure point.

- Primary Cause: A passivating layer of magnesium oxide (MgO) on the magnesium surface, or the presence of trace moisture.[3]
- Troubleshooting Steps:
 - Re-check Anhydrous Conditions: Ensure all glassware was meticulously dried and solvents are truly anhydrous. Diethyl ether should be distilled from a drying agent like sodium/benzophenone immediately before use.[6]
 - Activate the Magnesium: Add a single crystal of iodine and gently warm the flask. If this fails, a small amount of 1,2-dibromoethane can be added; its reaction with magnesium is vigorous and exposes a fresh surface.
 - Mechanical Activation: Briefly crush a few turnings of the magnesium with a dry glass rod inside the reaction flask (under inert gas) to break the oxide layer.
 - "Entrainment": If available, add a few drops of a previously prepared, active Grignard reagent to initiate the reaction.

Q5: My final product shows low deuterium incorporation (<95%) by NMR or MS. What went wrong?

A5: Low deuterium incorporation points to contamination with a protic (hydrogen-containing) source.

- Potential Causes & Solutions:
 - Atmospheric Moisture: The Grignard reagent reacted with H₂O from the air during the D₂O quench.
 - Solution: Ensure a robust positive pressure of inert gas (Ar or N₂) is maintained throughout the entire process, especially during the D₂O addition.
 - Contaminated D₂O: The heavy water source may have absorbed atmospheric moisture over time.
 - Solution: Use a fresh, unopened ampule of high-purity D₂O (≥99.8%).
 - Incomplete Grignard Formation: If a significant amount of the tert-butyl halide starting material remains, it will be carried through the workup and contaminate the final product, leading to an artificially low purity reading.
 - Solution: Ensure the Grignard formation step goes to completion by allowing sufficient reaction time and observing the consumption of magnesium.

Q6: My yield is very low, and I've isolated a high-boiling side product. What is it?

A6: This is likely due to a side reaction called Wurtz coupling.

- Mechanism: The already-formed Grignard reagent (R-MgX) can react with the unreacted starting material (R-X) to form a dimer (R-R). For this synthesis, the byproduct would be 2,2,3,3-tetramethylbutane.
- Causes & Prevention:
 - High Local Concentration of Alkyl Halide: Adding the tert-butyl chloride too quickly creates regions where it is more likely to encounter the Grignard reagent than the magnesium

surface.

- Solution: Maintain a slow, dropwise addition rate to ensure the halide reacts with the magnesium as it is introduced. Use dilute solutions.[3]
- High Temperature: This side reaction is often accelerated at higher temperatures.
 - Solution: Control the addition rate to maintain a gentle, not-too-vigorous, reflux. Avoid external heating after the reaction has initiated.

Section 4: Analytical & Purification Strategies

Q7: How can I accurately determine the isotopic purity of my **2-Methylpropane-2-d**?

A7: A combination of ¹H NMR and Mass Spectrometry is the most robust approach.

- ¹H NMR Spectroscopy:
 - Principle: In a ¹H NMR spectrum, the signal for the methine proton (-CH) in the non-deuterated impurity will appear as a decet (a multiplet of 10 lines) around 1.7 ppm. The signal for the nine methyl protons (-CH₃) will appear as a singlet around 0.9 ppm.
 - Quantification: The isotopic purity can be calculated by comparing the integration of the residual methine proton signal to the integration of the methyl proton signal.
 - % Deuterium Incorporation = $[1 - (\text{Integration of CH signal} * 9)] * 100$
 - Expertise: This calculation assumes the methyl protons are 100% ¹H, which is a valid assumption. High-field NMR (≥400 MHz) is recommended for accurate integration of the small impurity signal.[12]
- Mass Spectrometry (GC-MS):
 - Principle: GC-MS separates the volatile product from any non-volatile impurities and then measures its mass-to-charge ratio (m/z). **2-Methylpropane-2-d** will have a molecular ion peak (M⁺) at m/z 59, while the non-deuterated version will be at m/z 58.[13]

- Quantification: By comparing the relative intensities of the ion peaks at m/z 58 and 59 (after correcting for natural ^{13}C abundance), the isotopic distribution can be accurately determined.[14]

Data Presentation: Comparison of Analytical Techniques

Technique	Primary Advantage	Primary Limitation	Destructive?
^1H NMR	Gold standard for structural confirmation and accurate quantification.[12]	Lower sensitivity; requires more sample.	No
^2H NMR	Directly observes the deuterium signal for confirmation.[15]	Less quantitative; low sensitivity.	No
GC-MS	Exceptional sensitivity and speed; separates volatile impurities.[13]	Provides no positional information; quantification requires correction.	Yes

Section 5: Visualization of Key Workflows

Diagram 1: Synthesis Workflow

This diagram illustrates the critical steps and decision points in the synthesis of **2-Methylpropane-2-d**.

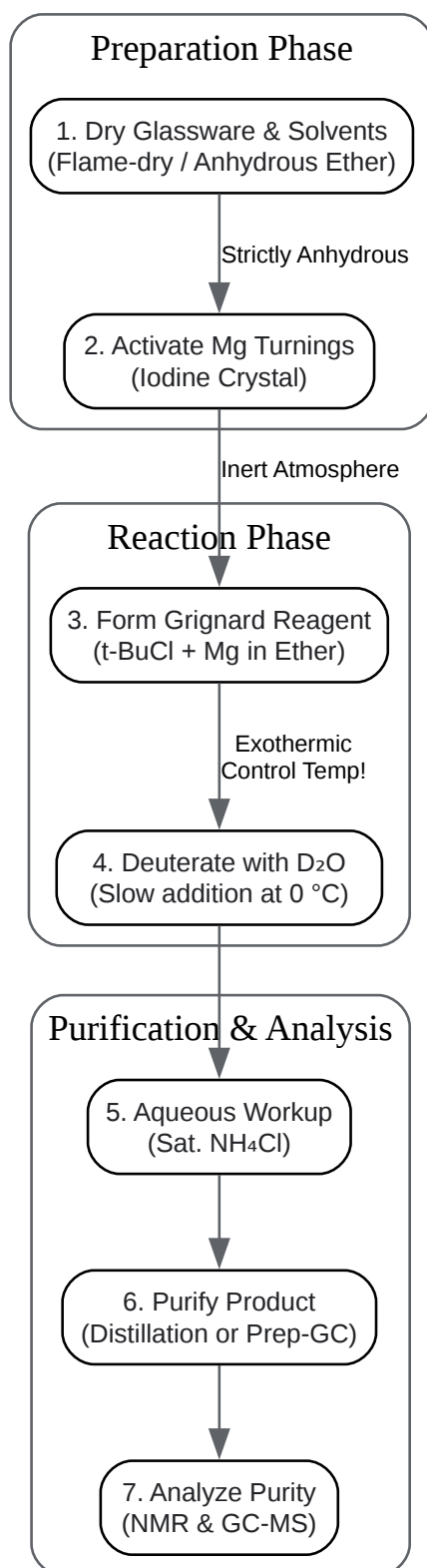

[Click to download full resolution via product page](#)

Caption: Key stages in the synthesis of **2-Methylpropane-2-d**.

Diagram 2: Troubleshooting Low Deuterium Incorporation

This decision tree helps diagnose the root cause of incomplete deuteration.

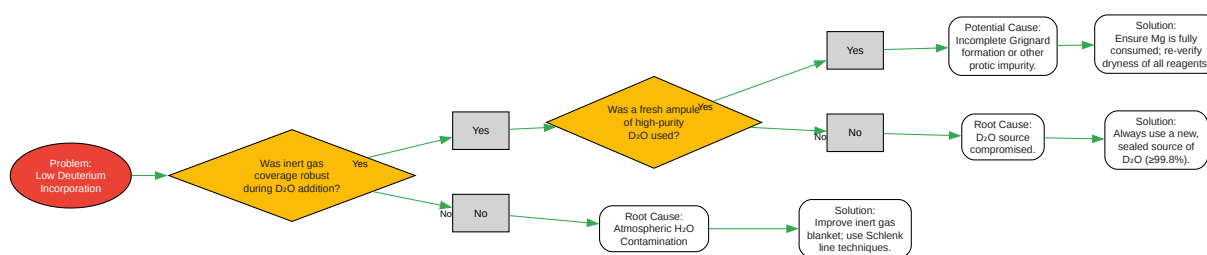

[Click to download full resolution via product page](#)

Caption: Diagnostic workflow for low deuteration issues.

References

- Le, L. (2013, April 5). Synthesis of 2-Methyl-2-Hexanol-The Grignard Reaction. Lu Le Laboratory. [\[Link\]](#)
- Posner, G. H., & Whitten, C. E. (1976). SECONDARY AND TERTIARY ALKYL KETONES FROM CARBOXYLIC ACID CHLORIDES AND LITHIUM PHENYLTHIO(ALKYL)CUPRATE REAGENTS: tert-BUTYL PHENYL KETONE. *Organic Syntheses*, 55, 122. [\[Link\]](#)
- Analytical Characterization of Deuterated Compounds: Combining NMR, GC-MS, and LC-MS Techniques. (n.d.). ResolveMass Laboratories Inc. Retrieved February 3, 2026, from [\[Link\]](#)
- Grignard Reagent Synthesis Reaction Mechanism - Organic Chemistry. (2015, November 11). The Organic Chemistry Tutor. [\[Link\]](#)

- Preparing Anhydrous Reagents and Equipment. (n.d.). Moodle@Units. Retrieved February 3, 2026, from [\[Link\]](#)
- Purifying and Drying Diethyl Ether For Grignard Reactions Using Potassium Hydroxide and Sodium. (2018, January 27). NileRed. [\[Link\]](#)
- Grignard reagents and drying. (2021, March 5). Reddit. [\[Link\]](#)
- Grignard successes and failures. (2016, February 18). Sciencemadness.org. [\[Link\]](#)
- Grignard Reagents. (2023, January 22). Chemistry LibreTexts. [\[Link\]](#)
- Preparative Gas Chromatography and Its Applications. (2016, August 8). ResearchGate. [\[Link\]](#)
- CASE STUDY - Determination of Isotopic Purity by Accurate Mass LC/MS. (n.d.). Almac Group. [\[Link\]](#)

Need Custom Synthesis?

BenchChem offers custom synthesis for rare earth carbides and specific isotopic labeling.

Email: info@benchchem.com or [Request Quote Online](#).

Sources

- 1. [researchgate.net](https://www.researchgate.net) [[researchgate.net](https://www.researchgate.net)]
- 2. [reddit.com](https://www.reddit.com) [[reddit.com](https://www.reddit.com)]
- 3. pdf.benchchem.com [pdf.benchchem.com]
- 4. m.youtube.com [m.youtube.com]
- 5. chem.libretexts.org [chem.libretexts.org]
- 6. [youtube.com](https://www.youtube.com) [[youtube.com](https://www.youtube.com)]
- 7. [isotope.com](https://www.isotope.com) [[isotope.com](https://www.isotope.com)]
- 8. moodle2.units.it [moodle2.units.it]

- [9. Lu Le Laboratory: Synthesis of 2-Methyl-2-Hexanol-The Grignard Reaction-Lu Le Laboratory \[lulelaboratory.blogspot.com\]](#)
- [10. Organic Syntheses Procedure \[orgsyn.org\]](#)
- [11. gcms.cz \[gcms.cz\]](#)
- [12. pdf.benchchem.com \[pdf.benchchem.com\]](#)
- [13. resolvemass.ca \[resolvemass.ca\]](#)
- [14. almacgroup.com \[almacgroup.com\]](#)
- [15. sigmaaldrich.com \[sigmaaldrich.com\]](#)
- To cite this document: BenchChem. [Technical Support Center: Synthesis of High-Purity 2-Methylpropane-2-d]. BenchChem, [2026]. [Online PDF]. Available at: [\[https://www.benchchem.com/product/b078710#challenges-in-the-synthesis-of-high-purity-2-methylpropane-2-d\]](https://www.benchchem.com/product/b078710#challenges-in-the-synthesis-of-high-purity-2-methylpropane-2-d)

Disclaimer & Data Validity:

The information provided in this document is for Research Use Only (RUO) and is strictly not intended for diagnostic or therapeutic procedures. While BenchChem strives to provide accurate protocols, we make no warranties, express or implied, regarding the fitness of this product for every specific experimental setup.

Technical Support: The protocols provided are for reference purposes. Unsure if this reagent suits your experiment? [[Contact our Ph.D. Support Team for a compatibility check](#)]

Need Industrial/Bulk Grade? [Request Custom Synthesis Quote](#)

BenchChem

Our mission is to be the trusted global source of essential and advanced chemicals, empowering scientists and researchers to drive progress in science and industry.

Contact

Address: 3281 E Guasti Rd

Ontario, CA 91761, United States

Phone: (601) 213-4426

Email: info@benchchem.com