

Technical Guide: 2-Methylpropane-2-d (Isobutane-d1)

Author: BenchChem Technical Support Team. **Date:** May 2026

Compound of Interest

Compound Name: 2-Methylpropane-2-d

CAS No.: 13183-68-1

Cat. No.: B078710

[Get Quote](#)

Physicochemical Properties, Synthesis, and Applications in Drug Development

Executive Summary & Chemical Identity

2-Methylpropane-2-d (Isobutane-d1) is the isotopologue of isobutane where the hydrogen atom at the tertiary carbon position is replaced by deuterium. This specific substitution is of critical importance in physical organic chemistry and drug development because the tertiary C-H bond is the weakest in the molecule and the primary site of metabolic oxidation.

By replacing this "soft spot" with a stronger C-D bond, researchers utilize the Kinetic Isotope Effect (KIE) to probe reaction mechanisms and enhance the metabolic stability of tert-butyl-containing pharmacophores.

Property	Data
Chemical Name	2-Methylpropane-2-d
Synonyms	Isobutane-d1; 2-Deuterioisobutane; tert-Butyl deuteride (informal)
CAS Number	13183-68-1
Molecular Formula	or
Molecular Weight	59.13 g/mol (vs. 58.12 for non-deuterated)
Purity Grade	Typically ≥ 98 atom % D

Physicochemical Properties: Vapor Pressure & Density

Accurate knowledge of the vapor pressure and density is essential for the safe storage, handling, and quantitative analysis of **2-Methylpropane-2-d**, which exists as a liquefied gas under standard laboratory conditions.

Comparative Property Table

Data represents a synthesis of experimental literature values for isobutane and theoretical corrections for the deuterated isotopologue.

Property	Isobutane ()	2-Methylpropane-2-d ()	Notes
Boiling Point (1 atm)	-11.7 °C (261.4 K)	-12.0 °C (approx)	Deuterated hydrocarbons often exhibit slightly lower boiling points due to reduced dispersion forces.
Melting Point	-159.6 °C	-160 °C	Negligible shift.
Vapor Pressure (21 °C)	3.04 bar (44.1 psi)	~3.08 bar (Estimated)	See Vapor Pressure Isotope Effect below.
Liquid Density (25 °C)	0.551 g/mL	0.560 g/mL (Calculated)	Density increases proportionally to mass (~1.7%).
Critical Temperature	134.7 °C	~134 °C	
Flash Point	-83 °C	-83 °C	Extremely Flammable.

Technical Insight: Vapor Pressure Isotope Effect (VPIE)

While often treated identically to isobutane in engineering contexts, **2-Methylpropane-2-d** exhibits a phenomenon known as the Inverse Vapor Pressure Isotope Effect (

).

- Mechanism: In the liquid phase, the lighter protium isotopologue () has slightly larger vibrational amplitudes (Zero Point Energy) than the deuterated form. This leads to a slightly larger effective molar volume and stronger intermolecular van der Waals attractions for the H-form compared to the D-form.
- Result: The deuterated molecules are less tightly held in the liquid phase relative to the gas phase compared to their protium counterparts. Consequently, **2-Methylpropane-2-d** is slightly more volatile than standard isobutane.

- Magnitude: For branched alkanes, this effect is small () but measurable in high-precision manometry.

Density Calculation (Molar Volume Invariance)

Experimental density data for the pure deuterated gas is rare. However, it can be derived with high precision using the Molar Volume Invariance principle. The electronic cloud size (which dictates volume) is virtually identical between C-H and C-D bonds.

Experimental Protocols

For researchers requiring validation of these properties in-house, the following protocols ensure data integrity.

Protocol: Static Vapor Pressure Measurement

Objective: Determine the precise vapor pressure of **2-Methylpropane-2-d** at varying temperatures.

- Apparatus: Use an isoteniscope or a static pressure cell equipped with a high-precision capacitance manometer (accuracy Torr) and a thermostated bath (°C).
- Degassing (Critical Step):
 - Connect the sample cylinder to the vacuum line.
 - Freeze the sample using liquid nitrogen ().
 - Evacuate the headspace to remove non-condensable gases (air/nitrogen).
 - Thaw and refreeze. Repeat this Freeze-Pump-Thaw cycle at least 3 times. Failure to degas is the #1 source of error in VP measurements.

- Equilibration:
 - Immerse the cell in the thermostated bath.
 - Allow 30 minutes for thermal equilibrium.
 - Record pressure () and temperature ().
- Data Fitting: Fit data to the Antoine Equation:

Protocol: Vibrating Tube Densimetry

Objective: Measure liquid density under pressure.

- Instrument: Anton Paar DMA HPM (High Pressure) or equivalent.
- Calibration: Calibrate the period of oscillation using vacuum (0 density) and a standard fluid (e.g., pure isobutane or propane) at the target temperature and pressure.
- Loading:
 - Connect the sample cylinder via stainless steel capillary tubing.
 - Pressurize the system to at least 2 bar above the vapor pressure to ensure a single liquid phase.
- Measurement: Record the oscillation period. Density is calculated via:

Synthesis and Preparation

The synthesis of **2-Methylpropane-2-d** is a classic example of Grignard chemistry adapted for isotopic labeling.

Synthesis Workflow

The most reliable route involves the hydrolysis of a tert-butyl Grignard reagent with heavy water ().

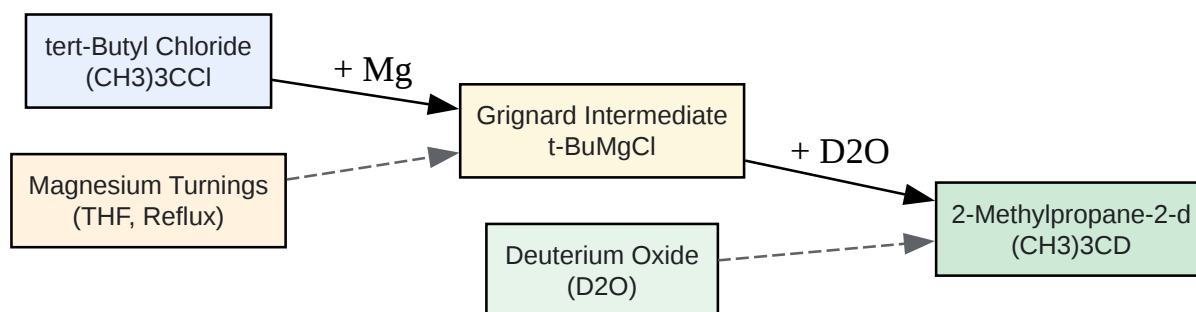

[Click to download full resolution via product page](#)

Figure 1: Synthesis pathway for **2-Methylpropane-2-d** via Grignard hydrolysis.

Step-by-Step Procedure

- Activation: Activate Magnesium turnings with iodine in dry THF under Argon atmosphere.
- Formation: Add tert-butyl chloride dropwise. Maintain gentle reflux to form t-butylmagnesium chloride.
- Quenching: Cool the solution to 0°C. Slowly add (99.9 atom % D).
- Collection: The product is a gas. The reaction vessel must be connected to a cold trap (dry ice/acetone) to condense the evolving **2-Methylpropane-2-d**.
- Purification: Distill the condensate through a low-temperature column to remove THF vapors.

Applications in Drug Development: The Kinetic Isotope Effect

In drug discovery, **2-Methylpropane-2-d** serves as a fundamental model for Metabolic Stability Studies.

The "Metabolic Soft Spot"

The tert-butyl group is common in drug architecture. However, the tertiary C-H bond is prone to oxidation by Cytochrome P450 (CYP450) enzymes, leading to rapid clearance (short half-life).

Deuterium Switching Strategy

Replacing H with D at the tertiary position creates a "Deuterium Switch."

- **Bond Strength:** The C-D bond is shorter and stronger than the C-H bond due to lower Zero Point Energy.
- **Primary Kinetic Isotope Effect (KIE):** Breaking the C-D bond in the rate-determining step of oxidation requires more energy.
- **Outcome:**

ratios typically range from 2 to 5. This significantly reduces the rate of metabolism, potentially extending the drug's half-life without altering its binding affinity or potency.

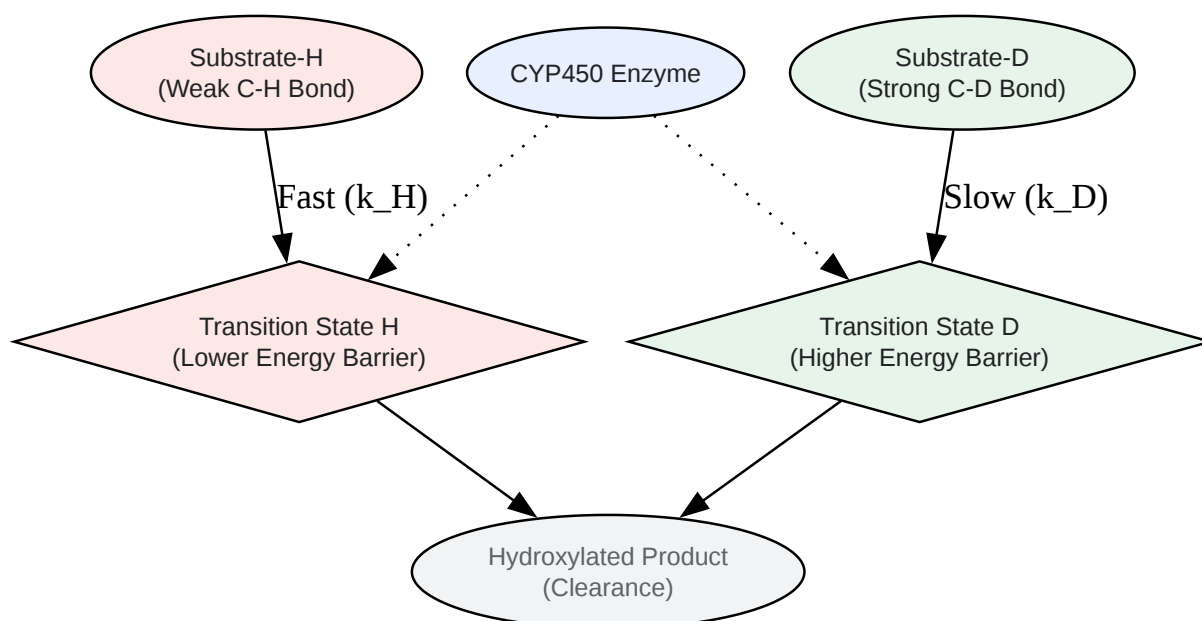

[Click to download full resolution via product page](#)

Figure 2: Mechanistic comparison of CYP450 oxidation rates for Protium (H) vs. Deuterium (D) substrates.

References

- Sigma-Aldrich.**2-Methylpropane-2-d** Product Specification (CAS 13183-68-1).[Link](#)
- PubChem.**2-Methylpropane-2-d** Compound Summary. National Library of Medicine. [Link](#)
- NIST Chemistry WebBook.Isobutane Thermophysical Properties.[Link](#)
- Brown, H. C., & Russell, G. A. (1952).[1] The Photochlorination of **2-Methylpropane-2-d**...[1] The Question of Free Radical Rearrangement. Journal of the American Chemical Society.[1] [2] [Link](#)[1]
- Bigeleisen, J., et al. (1963). Molecular Geometry and the Vapor Pressure of Isotopic Molecules.[3] Journal of Chemical Physics. (Fundamental theory on VPIE).

Need Custom Synthesis?

BenchChem offers custom synthesis for rare earth carbides and specific isotopic labeling.

Email: info@benchchem.com or [Request Quote Online](#).

Sources

- [1. masterorganicchemistry.com](https://www.masterorganicchemistry.com) [[masterorganicchemistry.com](https://www.masterorganicchemistry.com)]
- [2. pubs.acs.org](https://pubs.acs.org) [pubs.acs.org]
- [3. researchgate.net](https://www.researchgate.net) [[researchgate.net](https://www.researchgate.net)]
- To cite this document: BenchChem. [Technical Guide: 2-Methylpropane-2-d (Isobutane-d1)]. BenchChem, [2026]. [Online PDF]. Available at: [<https://www.benchchem.com/product/b078710/docs#technical-guide-2-methylpropane-2-d-isobutane-d1>]

Disclaimer & Data Validity:

The information provided in this document is for Research Use Only (RUO) and is strictly not intended for diagnostic or therapeutic procedures. While BenchChem strives to provide accurate protocols, we make no warranties, express or implied, regarding the fitness of this product for every specific experimental setup.

Technical Support: The protocols provided are for reference purposes. Unsure if this reagent suits your experiment?

Need Industrial/Bulk Grade? [Request Custom Synthesis Quote](#)

BenchChem

Our mission is to be the trusted global source of essential and advanced chemicals, empowering scientists and researchers to drive progress in science and industry.

Contact

Address: 3281 E Guasti Rd
Ontario, CA 91761, United States
Phone: (601) 213-4426
Email: info@benchchem.com

[Contact our Ph.D. Support Team for a compatibility check](#)