

Performance Evaluation Guide: InP-based QLEDs vs. Traditional CdSe QLEDs

Author: BenchChem Technical Support Team. **Date:** May 2026

Compound of Interest

Compound Name: Indium(III) Phosphate

CAS No.: 14693-82-4

Cat. No.: B078082

[Get Quote](#)

Executive Summary: The Green Shift in Photonics

For decades, Cadmium Selenide (CdSe) quantum dots have set the benchmark for narrow-bandwidth, high-efficiency electroluminescence. However, the inherent toxicity of cadmium poses severe regulatory hurdles (RoHS compliance) and safety risks in biological applications. Indium Phosphide (InP) has emerged as the primary "eco-friendly" alternative.^[1]

This guide provides a rigorous technical comparison of InP-based QLEDs against traditional CdSe counterparts. While InP performance in the red spectrum has reached parity with CdSe, significant physics-based challenges remain in the green and blue regions.^[2] We analyze these through the lens of quantum efficiency, stability, and material toxicity.

Material Physics & Device Architecture

To evaluate performance, one must first understand the fundamental material differences that dictate efficiency.

2.1 Quantum Confinement & Defect Tolerance

- CdSe (Traditional): Ionic character. Highly defect-tolerant. Surface defects do not significantly quench luminescence.
- InP (Alternative): Covalent character. Highly sensitive to surface oxidation and dangling bonds. Requires complex multi-shelling (e.g., InP/ZnSe/ZnS) to achieve high Photoluminescence Quantum Yield (PLQY).[2]

2.2 The "Electron Leakage" Bottleneck

A critical failure mechanism in InP QLEDs is charge imbalance.[3] InP has a smaller effective electron mass (

) compared to CdSe, leading to excessive electron mobility. This causes electrons to "overshoot" the recombination zone, leaking into the Hole Transport Layer (HTL) and causing non-radiative decay.

Diagram 1: Energy Band Alignment & Leakage Mechanism The following diagram illustrates the band alignment differences, highlighting the electron leakage pathway in InP devices.

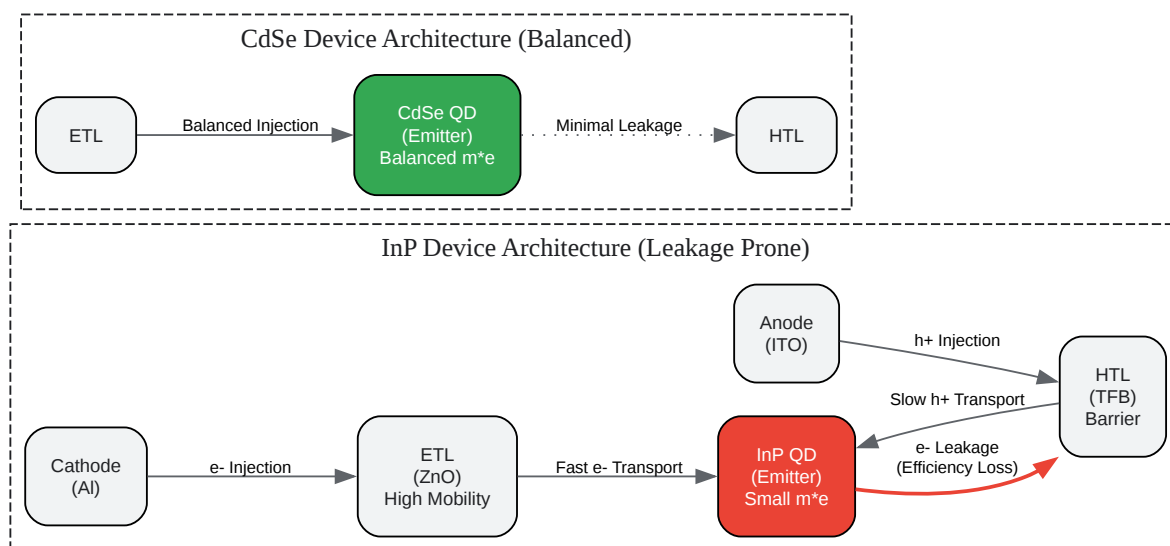

[Click to download full resolution via product page](#)

Caption: Comparison of charge transport dynamics. InP devices suffer from electron leakage due to high electron mobility and lower injection barriers compared to CdSe.

Comparative Performance Metrics

The following data synthesizes current literature values (as of late 2024/early 2025) for state-of-the-art laboratory devices.

Table 1: Performance Specifications (InP vs. CdSe)

Metric	Parameter	InP-based QLED (Red)	CdSe-based QLED (Red)	InP-based QLED (Green)	CdSe-based QLED (Green)
Efficiency	Peak EQE (%)	21.0 – 22.5%	22.0 – 25.0%	13.0 – 16.3%	> 22.0%
Color Purity	FWHM (nm)	35 – 40 nm	< 20 nm	38 – 45 nm	< 25 nm
Stability	T50 Lifetime (h)*	~100,000	> 1,000,000	< 1,000	> 500,000
Brightness	Max Luminance (cd/m ²)	~100,000	> 300,000	~50,000	> 400,000
Toxicity	Heavy Metals	None (Cd-Free)	Contains Cadmium	None	Contains Cadmium

*Lifetime estimated at 100 nits initial brightness.

Key Analysis:

- **The Red Gap is Closed:** InP red emitters have achieved near-unity PLQY and EQEs comparable to CdSe, driven by optimized ZnSe shelling protocols [1, 4].
- **The Green Valley:** Green InP LEDs lag significantly. The synthesis of green-emitting InP cores requires smaller sizes, increasing surface-to-volume ratio and oxidation susceptibility. This results in broader emission (FWHM >35nm) and lower efficiency [1, 6].

- Blue Emission: Blue InP QLEDs are currently non-competitive (EQE < 3%) due to the extreme difficulty in synthesizing ultra-small, defect-free InP cores [4].

Experimental Protocol: Validating QLED Performance

For researchers transitioning to InP, standardizing the measurement protocol is vital to avoid "hero data" artifacts.

4.1 Protocol: External Quantum Efficiency (EQE) Measurement

Objective: Accurately determine the ratio of emitted photons to injected electrons.

Workflow Diagram:

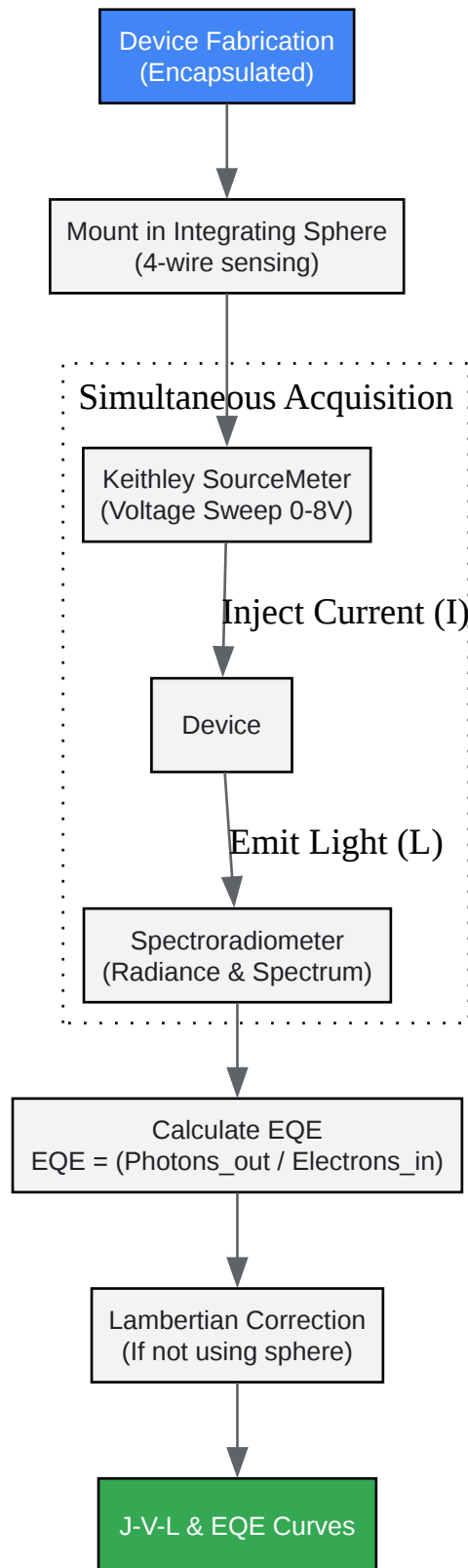

[Click to download full resolution via product page](#)

Caption: Standardized workflow for EQE measurement using an integrating sphere to capture total flux, eliminating angular dependence errors.

4.2 Step-by-Step Methodology

- Device Encapsulation: InP QDs are highly sensitive to moisture. Encapsulate devices with UV-curable epoxy and a glass cover slip in a glovebox (ppm, ppm) before testing in ambient air.
- Source-Measure Configuration: Use a Keithley 2400 or 2600 series SourceMeter. Connect in a 4-wire configuration to eliminate voltage drop across leads.
- Optical Calibration: Calibrate the spectroradiometer (e.g., Konica Minolta CS-2000 or Ocean Optics) using a NIST-traceable tungsten-halogen lamp.
- Sweep Parameters:
 - Voltage Step: 0.1 V
 - Delay: 50 ms (to minimize self-heating artifacts).

- Calculation:

Where

is the spectral power distribution,

is current,

is Planck's constant, and

is elementary charge.^{[1][2][4][5][6][7][8]}

Critical Caution: InP devices often exhibit "efficiency roll-off" at high current densities due to Auger recombination. Always report EQE at a specific luminance (e.g., EQE @ 1000 nits), not just the peak value [7].

Relevance to Drug Development & Bio-Imaging

While this guide focuses on LEDs, the material comparison directly impacts bio-imaging applications (e.g., fluorescent tagging).

- Toxicity: For in vivo imaging, CdSe QDs pose a risk of releasing ions if the shell is compromised. InP is chemically stable and non-toxic, making it the preferred candidate for clinical translation [1].
- NIR/SWIR Windows: InP-based structures can be tuned to the Near-Infrared (NIR) and Short-Wave Infrared (SWIR) windows. This allows for deep-tissue imaging with reduced autofluorescence, a capability where InP outperforms traditional organic dyes and rivals GaAs without the arsenic toxicity [13].

References

- Green InP-based quantum dot light-emitting diodes made efficient and stable. The Innovation. [Link](#)
- EL performance of the InP-and CdSe-QLEDs. ResearchGate. [Link](#)
- Boosting electroluminescence performance of all solution processed InP based QLEDs. Optica. [Link](#)
- Advances and Challenges in Heavy-Metal-Free InP Quantum Dot Light-Emitting Diodes. MDPI. [Link](#)
- Environmentally Friendly InP-Based Quantum Dots for Efficient Wide Color Gamut Displays. ACS Energy Letters. [Link](#)
- Constructing low-efficiency roll-off InP-based QLEDs. Optica. [Link](#)
- High-brightness green InP-based QLEDs enabled by in-situ passivating core surface. Materials Futures. [Link](#)
- InP-based quantum-dot-on-chip LEDs: excitation with violet or blue light? Optica. [Link](#)
- Highly efficient light-emitting diodes via self-assembled InP quantum dots. PubMed. [Link](#)

- InGaAs/InP and Ge-on-Si SPADs for SWIR applications. Image Sensors World. [Link](#)

Need Custom Synthesis?

BenchChem offers custom synthesis for rare earth carbides and specific isotopic labeling.

Email: info@benchchem.com or [Request Quote Online](#).

Sources

- 1. OPG [opg.optica.org]
- 2. the-innovation.org [the-innovation.org]
- 3. researchgate.net [researchgate.net]
- 4. OPG [opg.optica.org]
- 5. materialsfutures.org [materialsfutures.org]
- 6. mdpi.com [mdpi.com]
- 7. researchgate.net [researchgate.net]
- 8. OPG [opg.optica.org]
- To cite this document: BenchChem. [Performance Evaluation Guide: InP-based QLEDs vs. Traditional CdSe QLEDs]. BenchChem, [2026]. [Online PDF]. Available at: [<https://www.benchchem.com/product/b078082/docs#performance-evaluation-guide-inp-based-qleds-vs-traditional-cdse-qleds>]

Disclaimer & Data Validity:

The information provided in this document is for Research Use Only (RUO) and is strictly not intended for diagnostic or therapeutic procedures. While BenchChem strives to provide accurate protocols, we make no warranties, express or implied, regarding the fitness of this product for every specific experimental setup.

Technical Support: The protocols provided are for reference purposes. Unsure if this reagent suits your experiment?

Need Industrial/Bulk Grade? [Request Custom Synthesis Quote](#)

BenchChem

Our mission is to be the trusted global source of essential and advanced chemicals, empowering scientists and researchers to drive progress in science and industry.

Contact

Address: 3281 E Guasti Rd

Ontario, CA 91761, United States

Phone: (601) 213-4426

Email: info@benchchem.com

[Contact our Ph.D. Support Team for a compatibility check](#)