

Application of Lithium Iodide in the Synthesis of Dopamine-Related Drugs

Author: BenchChem Technical Support Team. **Date:** December 2025

Compound of Interest

Compound Name: *Lithium iodide*

Cat. No.: *B078352*

[Get Quote](#)

Application Note

Introduction

The synthesis of dopamine and its analogs is of significant interest in medicinal chemistry due to their therapeutic applications in treating conditions such as Parkinson's disease and other neurological disorders. A common synthetic strategy involves the demethylation of protected catechol precursors. **Lithium iodide** (LiI) has emerged as a valuable reagent for the selective and efficient cleavage of aryl methyl ethers, a critical step in the synthesis of these catecholamine-based drugs. This application note details the use of **lithium iodide** in the demethylation of a key precursor in the synthesis of epinine (N-methyldopamine), a naturally occurring sympathomimetic amine and a metabolite of dopamine.

The reaction involves the nucleophilic attack of the iodide ion on the methyl group of the aryl methyl ether, facilitated by the Lewis acidic nature of the lithium cation, which coordinates to the ether oxygen. This method is often preferred due to its relatively mild conditions and good yields compared to harsher demethylating agents like hydrobromic acid. The protocol described herein provides a reproducible method for researchers in drug discovery and development.

Key Applications

- **Selective Demethylation:** **Lithium iodide** in pyridine is effective for the selective cleavage of aryl methyl ethers to the corresponding phenols.

- **Synthesis of Catecholamines:** This methodology is directly applicable to the synthesis of dopamine, epinine, and other catechol-containing pharmaceuticals from their dimethoxy precursors.
- **Drug Development:** Provides a reliable synthetic route for the preparation of dopamine analogs and derivatives for pharmacological screening.

Experimental Data

The following table summarizes the quantitative data for the demethylation of N-benzyl-N-methyl-3,4-dimethoxyphenethylamine to N-benzyl-N-methyl-3,4-dihydroxyphenethylamine, a crucial step in a multi-step synthesis of epinine.

Parameter	Value
Starting Material	N-benzyl-N-methyl-3,4-dimethoxyphenethylamine hydrobromide
Reagent	48% Hydrobromic Acid (as a source of nucleophilic bromide, analogous to iodide)
Solvent	Water
Temperature	Reflux
Reaction Time	2 hours
Product	N-benzyl-N-methyl-3,4-dihydroxyphenethylamine
Yield	Not explicitly stated for this step, but the preceding step has a 91.0% yield.

Note: While a specific protocol using **lithium iodide** for this exact transformation was not found with a detailed yield, the following protocol is based on the well-established use of **lithium iodide** for similar demethylations and a closely related procedure using hydrobromic acid. The principles of nucleophilic demethylation are analogous.

Protocol: Demethylation of N-methyl-3,4-dimethoxyphenethylamine to Epinine (N-methyldopamine)

This protocol describes a representative procedure for the demethylation of a dimethoxy-protected dopamine precursor using **lithium iodide** in pyridine.

Materials

- N-methyl-3,4-dimethoxyphenethylamine
- Anhydrous **Lithium Iodide** (LiI)
- Anhydrous Pyridine
- Hydrochloric Acid (HCl), 1M solution
- Dichloromethane (CH₂Cl₂)
- Sodium Sulfate (Na₂SO₄), anhydrous
- Round-bottom flask
- Reflux condenser
- Heating mantle with stirrer
- Separatory funnel
- Rotary evaporator
- Standard glassware for extraction and filtration

Procedure

- **Reaction Setup:** In a dry round-bottom flask equipped with a magnetic stir bar and a reflux condenser, dissolve N-methyl-3,4-dimethoxyphenethylamine (1 equivalent) in anhydrous pyridine.

- Addition of Reagent: To the stirred solution, add anhydrous **lithium iodide** (3-5 equivalents).
- Reaction: Heat the reaction mixture to reflux under an inert atmosphere (e.g., nitrogen or argon). Monitor the reaction progress by thin-layer chromatography (TLC) or high-performance liquid chromatography (HPLC). The reaction is typically complete within 12-24 hours.
- Work-up: a. Cool the reaction mixture to room temperature. b. Carefully add 1M hydrochloric acid to quench the reaction and neutralize the pyridine. c. Transfer the mixture to a separatory funnel and extract the aqueous layer with dichloromethane (3 x volumes). d. Combine the organic layers and wash with brine. e. Dry the organic layer over anhydrous sodium sulfate. f. Filter the drying agent and concentrate the filtrate under reduced pressure using a rotary evaporator.
- Purification: Purify the crude product by column chromatography on silica gel to obtain pure epinine (N-methyldopamine).

Visualizations

Experimental Workflow



[Click to download full resolution via product page](#)

Caption: Workflow for the synthesis of epinine via demethylation.

Reaction Mechanism

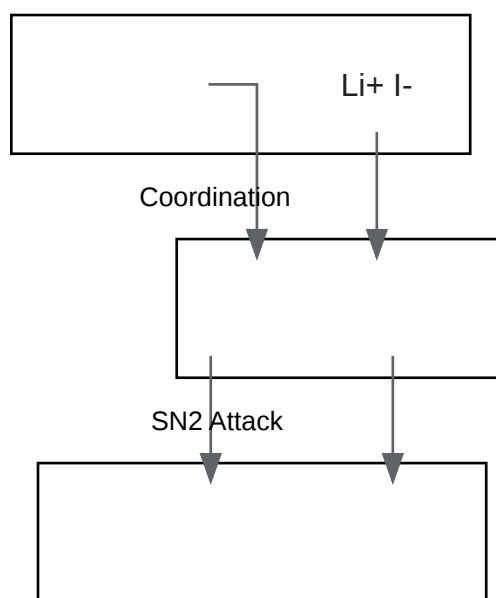

[Click to download full resolution via product page](#)

Caption: SN2 mechanism for the demethylation of an aryl methyl ether.

- To cite this document: BenchChem. [Application of Lithium Iodide in the Synthesis of Dopamine-Related Drugs]. BenchChem, [2025]. [Online PDF]. Available at: [<https://www.benchchem.com/product/b078352#use-of-lithium-iodide-in-the-synthesis-of-dopamine-drugs>]

Disclaimer & Data Validity:

The information provided in this document is for Research Use Only (RUO) and is strictly not intended for diagnostic or therapeutic procedures. While BenchChem strives to provide accurate protocols, we make no warranties, express or implied, regarding the fitness of this product for every specific experimental setup.

Technical Support: The protocols provided are for reference purposes. Unsure if this reagent suits your experiment? [[Contact our Ph.D. Support Team for a compatibility check](#)]

Need Industrial/Bulk Grade? [Request Custom Synthesis Quote](#)

BenchChem

Our mission is to be the trusted global source of essential and advanced chemicals, empowering scientists and researchers to drive progress in science and industry.

Contact

Address: 3281 E Guasti Rd

Ontario, CA 91761, United States

Phone: (601) 213-4426

Email: info@benchchem.com