

Application Note & Protocol: Competitive ELISA for the Quantification of 6-Hydroxyestriol

Author: BenchChem Technical Support Team. **Date:** May 2026

Compound of Interest

Compound Name: 6-Hydroxyestriol

CAS No.: 14507-00-7

Cat. No.: B078679

[Get Quote](#)

Authored by: Senior Application Scientist, Gemini Introduction: The Significance of 6-Hydroxyestriol

6-Hydroxyestriol is a hydroxylated metabolite of estriol, an estrogen that is produced in significant amounts during pregnancy.[1][2][3] While estriol is considered a weak estrogen, its metabolites, including **6-hydroxyestriol**, are subjects of interest in various physiological and pathological research areas.[2][4] Accurate quantification of **6-hydroxyestriol** in biological matrices is crucial for understanding its potential roles in endocrine function, metabolic regulation, and as a biomarker in certain conditions. The enzyme-linked immunosorbent assay (ELISA) offers a sensitive and specific method for this purpose.

This document provides a comprehensive guide to the design and execution of a competitive ELISA for the quantitative determination of **6-hydroxyestriol**. We will delve into the underlying principles of the assay, provide detailed, step-by-step protocols, and discuss crucial aspects of data analysis and assay validation.

Assay Principle: Competitive Immunoassay for Small Molecule Detection

Due to its small size, **6-hydroxyestriol** is not amenable to a traditional sandwich ELISA format which requires the simultaneous binding of two antibodies.[5][6] Therefore, a competitive immunoassay is the method of choice.[7][8][9] In this format, free **6-hydroxyestriol** in the sample competes with a fixed amount of **6-hydroxyestriol** conjugated to a carrier protein (the coating antigen) for binding to a limited number of specific primary antibody binding sites.

The assay is performed in a microtiter plate coated with the **6-hydroxyestriol**-protein conjugate. The sample containing the unknown amount of **6-hydroxyestriol** is incubated with a specific primary antibody. This mixture is then added to the coated plate. The amount of primary antibody that binds to the plate is inversely proportional to the concentration of free **6-hydroxyestriol** in the sample. A secondary antibody conjugated to an enzyme, such as horseradish peroxidase (HRP), is then used to detect the plate-bound primary antibody. The addition of a chromogenic substrate for the enzyme results in a colorimetric signal. The intensity of the color is inversely proportional to the concentration of **6-hydroxyestriol** in the sample.

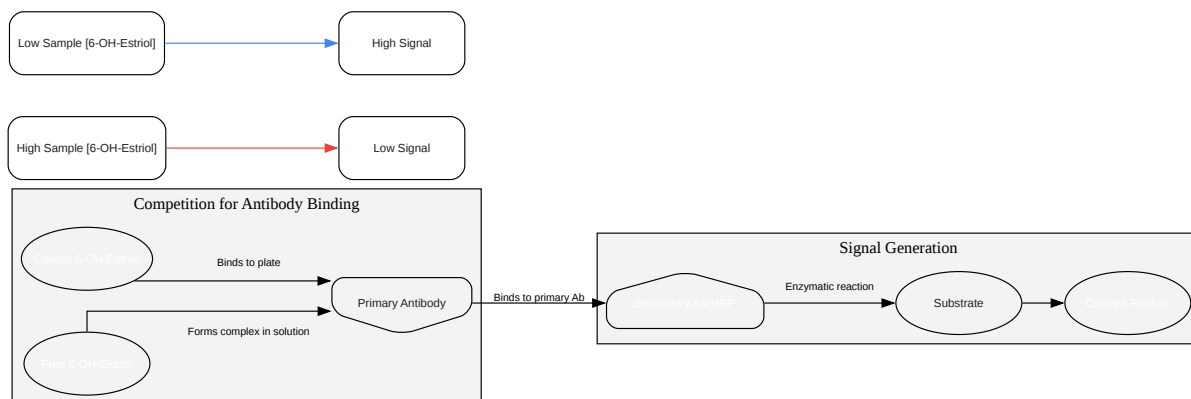

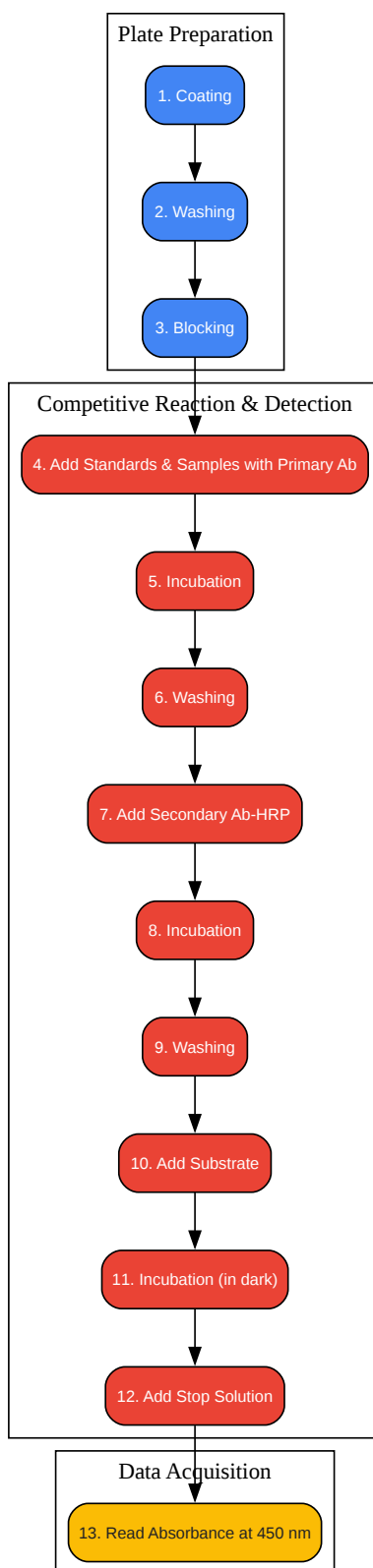

[Click to download full resolution via product page](#)

Caption: Step-by-step competitive ELISA workflow.

Step 1: Plate Coating

- Dilute the **6-hydroxyestriol**-BSA conjugate to a final concentration of 1-10 µg/mL in Coating Buffer. The optimal concentration needs to be determined experimentally. [10]2. Add 100 µL of the diluted conjugate to each well of a 96-well microtiter plate.
- Seal the plate and incubate overnight at 4°C. [11]

Step 2: Washing

- Aspirate the coating solution from the wells.
- Wash the plate 3 times with 200 µL of Wash Buffer (PBST) per well. [11]3. After the final wash, invert the plate and tap it firmly on a clean paper towel to remove any residual buffer.

Step 3: Blocking

- Add 200 µL of Blocking Buffer to each well. 2. Seal the plate and incubate for 1-2 hours at room temperature (RT).

Step 4: Competitive Reaction

- Prepare serial dilutions of the **6-hydroxyestriol** standard in Assay Buffer. A typical concentration range might be from 0.1 ng/mL to 100 ng/mL.
- Prepare your samples. Dilute them in Assay Buffer as necessary to fall within the standard curve range.
- In a separate dilution plate or tubes, mix equal volumes of each standard/sample dilution and the primary anti-**6-hydroxyestriol** antibody (at its predetermined optimal dilution in Assay Buffer).
- Incubate this mixture for 30-60 minutes at RT.
- Wash the blocked ELISA plate as described in Step 2.
- Transfer 100 µL of the pre-incubated standard/sample-antibody mixture to the corresponding wells of the coated and blocked ELISA plate.

- Seal the plate and incubate for 1-2 hours at RT. [10]

Step 5: Addition of Secondary Antibody

- Wash the plate 3 times with Wash Buffer as described in Step 2.
- Dilute the HRP-conjugated secondary antibody in Assay Buffer according to the manufacturer's instructions or pre-determined optimal dilution.
- Add 100 μ L of the diluted secondary antibody to each well.
- Seal the plate and incubate for 1 hour at RT. [11]

Step 6: Signal Development and Measurement

- Wash the plate 5 times with Wash Buffer. 2. Add 100 μ L of TMB Substrate to each well. 3. Incubate the plate in the dark at RT for 15-30 minutes. Monitor the color development.
- Stop the reaction by adding 50 μ L of Stop Solution to each well. The color will change from blue to yellow.
- Read the absorbance at 450 nm using a microplate reader within 30 minutes of adding the Stop Solution. [12]

III. Data Analysis

The goal of data analysis is to generate a standard curve from which the concentrations of **6-hydroxyestriol** in the unknown samples can be determined.

- Calculate the average absorbance for each set of replicate standards, controls, and samples.
- Subtract the average absorbance of the blank (zero standard) from all other absorbance readings.
- Generate the Standard Curve: Plot the average absorbance (Y-axis) against the corresponding concentration of the **6-hydroxyestriol** standards (X-axis). For competitive ELISAs, the resulting curve will be inversely proportional to the concentration. [13][14]4.

Curve Fitting: Use a four-parameter logistic (4-PL) curve fit, which typically provides the best fit for immunoassay data. [15][16]5. Determine Unknown Concentrations: Interpolate the concentration of **6-hydroxyestriol** in your samples from the standard curve using their average absorbance values. Remember to multiply the interpolated concentration by the sample dilution factor to obtain the final concentration in the original sample.

Standard Concentration (ng/mL)	Absorbance (450 nm) - Replicate 1	Absorbance (450 nm) - Replicate 2	Average Absorbance
0 (B ₀)	1.852	1.848	1.850
0.1	1.625	1.635	1.630
0.5	1.210	1.220	1.215
1.0	0.855	0.845	0.850
5.0	0.350	0.360	0.355
10.0	0.180	0.170	0.175
50.0	0.085	0.095	0.090

| 100.0 | 0.052 | 0.048 | 0.050 |

IV. Assay Validation

To ensure the reliability and reproducibility of your **6-hydroxyestriol** ELISA, it is essential to perform a thorough assay validation. [17]Key validation parameters include:

- Precision: Assessed by determining the intra-assay (within-run) and inter-assay (between-run) variability. The coefficient of variation (CV) should typically be less than 15-20%. [18]* Accuracy: Determined by spike and recovery experiments, where a known amount of **6-hydroxyestriol** is added to a sample matrix and the recovery is calculated.
- Sensitivity (Limit of Detection, LOD): The lowest concentration of **6-hydroxyestriol** that can be distinguished from the blank with a certain degree of confidence.

- **Specificity (Cross-reactivity):** The ability of the antibody to exclusively bind to **6-hydroxyestriol**. This is assessed by testing structurally related molecules (e.g., estriol, estradiol, estrone) to determine if they interfere with the assay.
- **Linearity of Dilution:** Demonstrates that the assay provides proportional results for samples at different dilutions.

For regulatory submissions, it is advisable to consult guidelines from authorities such as the FDA. [19][20][21]

V. Troubleshooting

Issue	Potential Cause(s)	Suggested Solution(s)
High background/Low signal-to-noise ratio	- Insufficient blocking- Antibody concentration too high- Inadequate washing	- Increase blocking time or try a different blocking agent- Optimize antibody concentrations- Ensure thorough washing between steps
Low signal	- Reagent degradation- Insufficient incubation times- Low antibody/antigen concentration	- Use fresh reagents- Optimize incubation times- Increase coating antigen or antibody concentrations
High variability (high CV)	- Pipetting errors- Inconsistent incubation times/temperatures- Plate not washed uniformly	- Calibrate pipettes and use consistent technique- Ensure uniform incubation conditions- Use a plate washer if available

VI. Conclusion

This application note provides a robust framework for the development and implementation of a competitive ELISA for the quantification of **6-hydroxyestriol**. By understanding the principles behind each step and performing a thorough optimization and validation, researchers can obtain accurate and reliable data to advance their scientific investigations.

References

- TMB Peroxidase (HRP) ELISA Substrate. Antibody Research Corporation. [\[Link\]](#)
- ELISA Coating and Blocking Protocol and Tips. Diagnostal. [\[Link\]](#)
- Competitive ELISA. Creative Diagnostics. [\[Link\]](#)
- ELISA Substrates. Surmodics IVD. [\[Link\]](#)
- Coupling to Carrier Proteins: An Overview. G-Biosciences. [\[Link\]](#)
- How to Generate an ELISA Standard Curve? Beta LifeScience. [\[Link\]](#)
- Competitive Immunoassays for the Detection of Small Molecules Using Single Molecule Arrays. Journal of the American Chemical Society. [\[Link\]](#)
- ELISA Blocking Buffers: Overview & Application. Excedr. [\[Link\]](#)
- Conjugation of haptens. PubMed - NIH. [\[Link\]](#)
- Enzyme-Substrate Reaction in ELISA. Creative Diagnostics. [\[Link\]](#)
- Hapten-Carrier Conjugation. Creative Biolabs. [\[Link\]](#)
- ELISA Blocking Agents & Blocking Solutions. G-Biosciences. [\[Link\]](#)
- How to Generate an ELISA Standard Curve. Boster Bio. [\[Link\]](#)
- Synaptic Systems standard protocol for ELISA. Synaptic Systems. [\[Link\]](#)
- ELISA Protocol. Arigo Biolaboratories. [\[Link\]](#)
- ELISA Protocol. Cusabio. [\[Link\]](#)
- ELISA Blocking Optimization: Reduce Background & Improve Sensitivity. Boster Bio. [\[Link\]](#)
- Competitive Immunoassays for the Detection of Small Molecules Using Single Molecule Arrays. PubMed. [\[Link\]](#)

- Competitive Immunoassays for the Detection of Small Molecules Using Single Molecule Arrays. ResearchGate. [\[Link\]](#)
- Hapten and carrier conjugation. ResearchGate. [\[Link\]](#)
- 6 alpha- and 6 beta-Hydroxyestriol. Synthesis, configurational assignments, and spectral properties. PubMed. [\[Link\]](#)
- ELISA Blocking Reagents / Blocking Buffers. Surmodics IVD. [\[Link\]](#)
- ELISA Blocking Buffer Solution. Biomat. [\[Link\]](#)
- Immunogenicity Testing of Therapeutic Protein Products —Developing and Validating Assays for Anti-Drug Antibody Detection February 2019. FDA. [\[Link\]](#)
- Assay Development for Immunogenicity Testing of Therapeutic Proteins. Regulations.gov. [\[Link\]](#)
- FDA Draft Guidance on Immunogenicity Testing. FDA. [\[Link\]](#)
- The physiological role of estriol during human fetal development is to act as antioxidant at lipophilic milieus of the central nervous system. PubMed. [\[Link\]](#)
- FDA Updates Analytical Validation Guidance. BioPharm International. [\[Link\]](#)
- Synthesis of 6 alpha-functionalized estriol haptens and protein conjugate thereof.
- A Practical Guide to Immunoassay Method Validation. PMC. [\[Link\]](#)
- The partial synthesis of 6-oxo-oestriol and 6 α '-hydroxyoestriol. PMC - NIH. [\[Link\]](#)
- Estriol. Wikipedia. [\[Link\]](#)
- What are the physiological estrogens? PubMed. [\[Link\]](#)
- Protein Breakdown. Rupa Health. [\[Link\]](#)
- Estriol. PubChem. [\[Link\]](#)

Need Custom Synthesis?

BenchChem offers custom synthesis for rare earth carbides and specific isotopic labeling.

Email: info@benchchem.com or [Request Quote Online](#).

Sources

- 1. 6 - and 6 -Hydroxyestriol. Synthesis, configurational assignments, and spectral properties - PubMed [pubmed.ncbi.nlm.nih.gov]
- 2. Estriol - Wikipedia [en.wikipedia.org]
- 3. Estriol | C₁₈H₂₄O₃ | CID 5756 - PubChem [pubchem.ncbi.nlm.nih.gov]
- 4. What are the physiological estrogens? - PubMed [pubmed.ncbi.nlm.nih.gov]
- 5. Competitive Immunoassays for the Detection of Small Molecules Using Single Molecule Arrays - PubMed [pubmed.ncbi.nlm.nih.gov]
- 6. researchgate.net [researchgate.net]
- 7. Competitive ELISA - Creative Diagnostics [creative-diagnostics.com]
- 8. pubs.acs.org [pubs.acs.org]
- 9. What is a Competitive ELISA? - Echelon Biosciences [echelon-inc.com]
- 10. arigobio.com [arigobio.com]
- 11. biossusa.com [biossusa.com]
- 12. cusabio.com [cusabio.com]
- 13. betalifesci.com [betalifesci.com]
- 14. Choosing how to analyse your ELISA | Abcam [abcam.com]
- 15. ELISA Data Analysis | Thermo Fisher Scientific - HK [thermofisher.com]
- 16. bosterbio.com [bosterbio.com]
- 17. A Practical Guide to Immunoassay Method Validation - PMC [pmc.ncbi.nlm.nih.gov]
- 18. bioanalysisforum.jp [bioanalysisforum.jp]
- 19. fda.gov [fda.gov]
- 20. regulations.gov [regulations.gov]
- 21. biopharminternational.com [biopharminternational.com]

- To cite this document: BenchChem. [Application Note & Protocol: Competitive ELISA for the Quantification of 6-Hydroxyestriol]. BenchChem, [2026]. [Online PDF]. Available at: [<https://www.benchchem.com/product/b078679/docs#application-note-protocol-competitive-elisa-for-the-quantification-of-6-hydroxyestriol>]

Disclaimer & Data Validity:

The information provided in this document is for Research Use Only (RUO) and is strictly not intended for diagnostic or therapeutic procedures. While BenchChem strives to provide accurate protocols, we make no warranties, express or implied, regarding the fitness of this product for every specific experimental setup.

Technical Support: The protocols provided are for reference purposes. Unsure if this reagent suits your experiment?

Need Industrial/Bulk Grade? [Request Custom Synthesis Quote](#)

BenchChem

Our mission is to be the trusted global source of essential and advanced chemicals, empowering scientists and researchers to drive progress in science and industry.

Contact

Address: 3281 E Guasti Rd
Ontario, CA 91761, United States
Phone: (601) 213-4426
Email: info@benchchem.com

[Contact our Ph.D. Support Team for a compatibility check](#)