

Anhydrous vs. Hydrated Aluminum Chloride: A Comparative Guide for Catalysis

Author: BenchChem Technical Support Team. **Date:** December 2025

Compound of Interest

Compound Name: Aluminum chloride oxide

Cat. No.: B078503

[Get Quote](#)

For Researchers, Scientists, and Drug Development Professionals

Aluminum chloride (AlCl_3) is a versatile Lewis acid catalyst pivotal in a multitude of organic transformations. Its efficacy, however, is critically dependent on its hydration state. This guide provides an objective comparison of anhydrous and hydrated aluminum chloride in catalysis, supported by experimental data and detailed protocols, to aid researchers in catalyst selection and experimental design.

Core Comparison: Lewis Acidity and Catalytic Activity

The primary distinction between anhydrous and hydrated aluminum chloride lies in their Lewis acidity. Anhydrous AlCl_3 is a potent Lewis acid, readily accepting electron pairs to activate electrophiles.^{[1][2]} This property is central to its catalytic activity in a wide range of reactions, most notably Friedel-Crafts acylations and alkylations.^{[3][4]}

In contrast, the hydrated form, aluminum chloride hexahydrate ($[\text{Al}(\text{H}_2\text{O})_6]\text{Cl}_3$), exhibits significantly diminished Lewis acidity. The water molecules in the coordination sphere of the aluminum ion donate electron pairs, effectively neutralizing its ability to act as a strong Lewis acid.^{[5][6]} Consequently, hydrated aluminum chloride is generally ineffective as a catalyst in reactions that rely on strong Lewis acid catalysis, such as the classic Friedel-Crafts acylation of simple aromatic compounds.^[5]

Performance in Friedel-Crafts Acylation

The Friedel-Crafts acylation is a cornerstone of organic synthesis for the formation of aryl ketones. This reaction serves as a clear delineator between the catalytic capabilities of anhydrous and hydrated aluminum chloride.

Table 1: Comparison of Anhydrous and Hydrated AlCl_3 in the Acylation of Benzene with Acetyl Chloride

Catalyst	Product	Yield (%)	Reaction Conditions	Reference
Anhydrous AlCl_3	Acetophenone	~90%	Benzene, Acetyl Chloride, 0-5°C then reflux	[7][8][9]
Hydrated AlCl_3 ($\text{AlCl}_3 \cdot 6\text{H}_2\text{O}$)	No Reaction/Trace	0%	Benzene, Acetyl Chloride	[5][6]

As the data indicates, anhydrous aluminum chloride is essential for the successful acylation of benzene. The use of hydrated aluminum chloride results in no significant product formation under typical Friedel-Crafts conditions.

Experimental Protocol: Friedel-Crafts Acylation of Benzene with Acetyl Chloride using Anhydrous AlCl_3

Materials:

- Anhydrous Aluminum Chloride (AlCl_3)
- Benzene (anhydrous)
- Acetyl Chloride (CH_3COCl)
- Dichloromethane (CH_2Cl_2 , anhydrous, as solvent)
- Ice bath

- Hydrochloric acid (HCl, concentrated)
- Water
- Sodium bicarbonate (NaHCO₃, saturated solution)
- Anhydrous magnesium sulfate (MgSO₄)
- Round-bottom flask with a reflux condenser and a dropping funnel
- Magnetic stirrer

Procedure:

- To a stirred suspension of anhydrous AlCl₃ (1.1 equivalents) in anhydrous dichloromethane in a round-bottom flask cooled in an ice bath, add acetyl chloride (1.0 equivalent) dropwise from a dropping funnel.
- After the addition of acetyl chloride, add benzene (1.0 equivalent) dropwise to the reaction mixture, maintaining the temperature at 0-5°C.
- Once the addition of benzene is complete, remove the ice bath and allow the reaction mixture to warm to room temperature. Then, heat the mixture to reflux for 1-2 hours to ensure the completion of the reaction.
- After reflux, cool the reaction mixture in an ice bath and carefully quench the reaction by the slow addition of crushed ice, followed by concentrated HCl.
- Separate the organic layer and wash it successively with water, saturated sodium bicarbonate solution, and brine.
- Dry the organic layer over anhydrous magnesium sulfate, filter, and concentrate under reduced pressure to obtain the crude acetophenone.
- Purify the product by distillation or chromatography.[\[10\]](#)[\[11\]](#)

The Surprising Catalytic Versatility of Hydrated Aluminum Chloride

While unsuitable for traditional Friedel-Crafts reactions, aluminum chloride hexahydrate is not catalytically inert. It has emerged as a mild, water-tolerant, and environmentally benign catalyst for a variety of other organic transformations.

Table 2: Catalytic Applications of Hydrated Aluminum Chloride ($\text{AlCl}_3 \cdot 6\text{H}_2\text{O}$)

Reaction	Substrates	Product	Yield (%)	Reference
Friedel-Crafts Alkylation of Indoles	Indole, Celastrol	C ₆ -indole-substituted celastrol	up to 99%	[12]
Hantzsch Dihydropyridine Synthesis	Aldehyde, β -ketoester, Ammonium Acetate	1,4-Dihydropyridine	74-80%	[13][14]
Reductive Cleavage of 2,1-Benzisoxazoles	2,1-Benzisoxazole	o-Aminobenzophenone	High yields	[15]

Experimental Protocol: Hantzsch Synthesis of 1,4-Dihydropyridines using $\text{AlCl}_3 \cdot 6\text{H}_2\text{O}$

Materials:

- Aluminum Chloride Hexahydrate ($\text{AlCl}_3 \cdot 6\text{H}_2\text{O}$)
- Aromatic or aliphatic aldehyde
- β -ketoester (e.g., ethyl acetoacetate)
- Ammonium acetate (NH_4OAc)
- Ethanol (as solvent, optional)

Procedure:

- In a round-bottom flask, mix the aldehyde (1 mmol), β -ketoester (2 mmol), ammonium acetate (1.5 mmol), and $\text{AlCl}_3 \cdot 6\text{H}_2\text{O}$ (10 mol%).
- For a solvent-free reaction, heat the mixture at 60-80°C with stirring. Alternatively, the reaction can be carried out in a minimal amount of ethanol under reflux.
- Monitor the reaction progress by Thin Layer Chromatography (TLC).
- Upon completion, cool the reaction mixture and add water.
- Collect the precipitated solid product by filtration, wash with cold water, and dry.
- Recrystallize the crude product from a suitable solvent (e.g., ethanol) to obtain the pure 1,4-dihydropyridine.

Visualizing the Catalytic Pathways

To further elucidate the distinct roles of anhydrous and hydrated aluminum chloride, the following diagrams illustrate their involvement in key catalytic cycles.

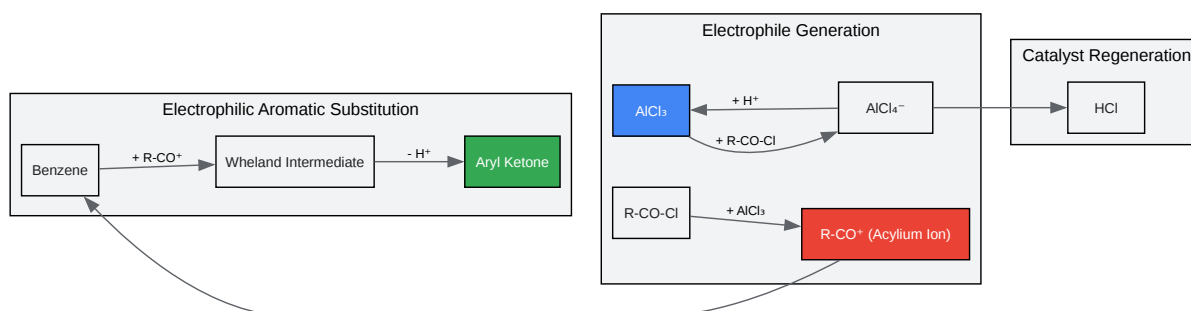

[Click to download full resolution via product page](#)

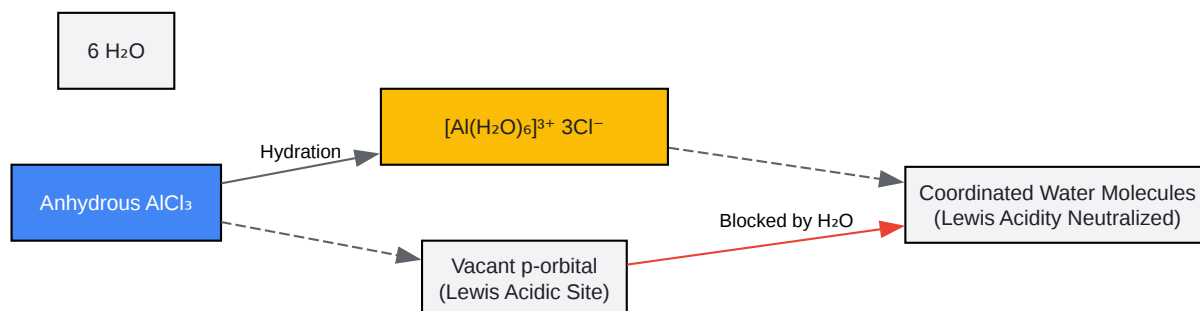
Figure 1: Catalytic cycle of Friedel-Crafts acylation using anhydrous AlCl_3 .

[Click to download full resolution via product page](#)

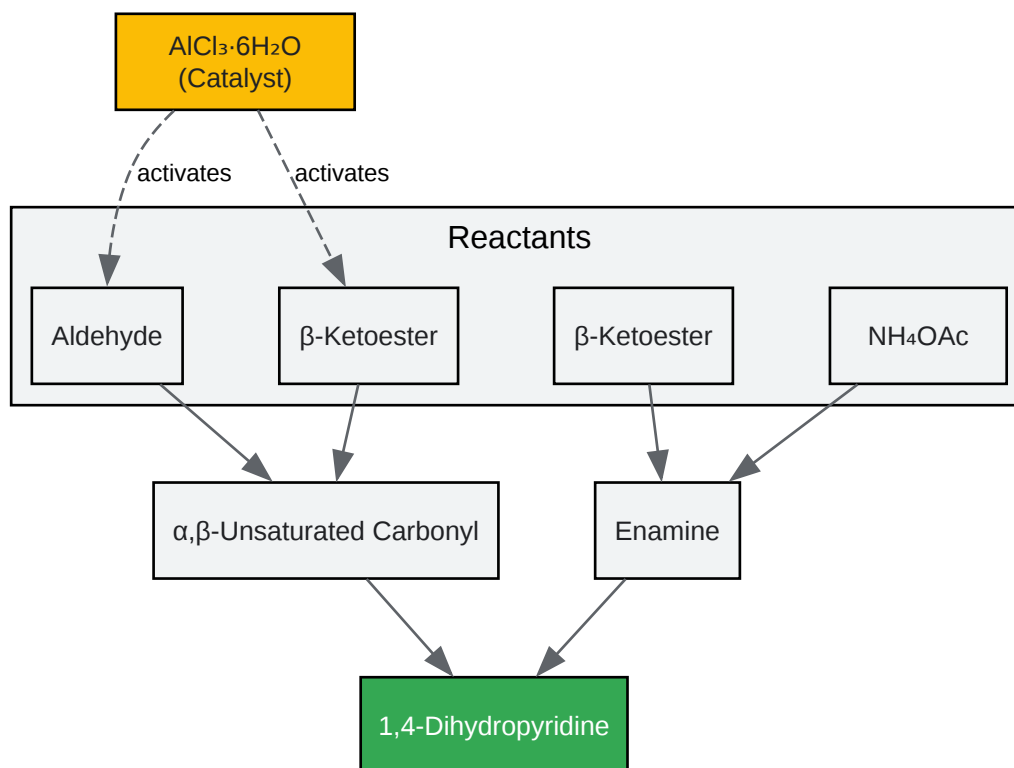
Figure 2: Deactivation of Lewis acidity in AlCl_3 upon hydration.

[Click to download full resolution via product page](#)

Figure 3: Proposed role of hydrated AlCl_3 in Hantzsch dihydropyridine synthesis.

Conclusion

The choice between anhydrous and hydrated aluminum chloride is dictated by the specific requirements of the chemical transformation. For reactions demanding a strong Lewis acid, such as Friedel-Crafts acylation, anhydrous aluminum chloride is indispensable. Its high reactivity necessitates careful handling under moisture-free conditions. Conversely, hydrated aluminum chloride, while unsuitable for such reactions, offers a mild, water-tolerant, and cost-effective catalytic alternative for a different spectrum of organic syntheses. Understanding these fundamental differences is crucial for the development of efficient and robust synthetic methodologies in research and industrial applications.

Need Custom Synthesis?

BenchChem offers custom synthesis for rare earth carbides and specific isotopic labeling.

Email: info@benchchem.com or [Request Quote Online](#).

References

- 1. eurekaselect.com [eurekaselect.com]
- 2. cic.azaruniv.ac.ir [cic.azaruniv.ac.ir]
- 3. Khan Academy [khanacademy.org]
- 4. wjpmr.com [wjpmr.com]
- 5. quora.com [quora.com]
- 6. youtube.com [youtube.com]
- 7. chemguide.co.uk [chemguide.co.uk]
- 8. quora.com [quora.com]
- 9. Benzene reacts with acetyl chloride in presence of class 11 chemistry CBSE [vedantu.com]
- 10. websites.umich.edu [websites.umich.edu]
- 11. chem.libretexts.org [chem.libretexts.org]
- 12. mdpi.com [mdpi.com]
- 13. Hantzsch pyridine synthesis - Wikipedia [en.wikipedia.org]

- 14. alfa-chemistry.com [alfa-chemistry.com]
- 15. researchgate.net [researchgate.net]
- To cite this document: BenchChem. [Anhydrous vs. Hydrated Aluminum Chloride: A Comparative Guide for Catalysis]. BenchChem, [2025]. [Online PDF]. Available at: [https://www.benchchem.com/product/b078503#comparing-anhydrous-vs-hydrated-aluminum-chloride-in-catalysis]

Disclaimer & Data Validity:

The information provided in this document is for Research Use Only (RUO) and is strictly not intended for diagnostic or therapeutic procedures. While BenchChem strives to provide accurate protocols, we make no warranties, express or implied, regarding the fitness of this product for every specific experimental setup.

Technical Support: The protocols provided are for reference purposes. Unsure if this reagent suits your experiment? [[Contact our Ph.D. Support Team for a compatibility check](#)]

Need Industrial/Bulk Grade? [Request Custom Synthesis Quote](#)

BenchChem

Our mission is to be the trusted global source of essential and advanced chemicals, empowering scientists and researchers to drive progress in science and industry.

Contact

Address: 3281 E Guasti Rd
Ontario, CA 91761, United States
Phone: (601) 213-4426
Email: info@benchchem.com