

Glycyl-dl-serine Crystallization Protocols: A Technical Support Guide

Author: BenchChem Technical Support Team. **Date:** May 2026

Compound of Interest

Compound Name: Glycyl-dl-serine

CAS No.: 2789-31-3

Cat. No.: B7782840

[Get Quote](#)

Welcome to the technical support center for **Glycyl-dl-serine** crystallization. This guide is designed for researchers, scientists, and drug development professionals to navigate the complexities of crystallizing this dipeptide. Here, you will find in-depth troubleshooting advice and frequently asked questions, grounded in scientific principles and practical experience, to help you achieve high-quality, reproducible crystalline material.

Frequently Asked Questions (FAQs)

Q1: What are the key physicochemical properties of Glycyl-dl-serine that influence its crystallization?

Understanding the fundamental properties of **Glycyl-dl-serine** is the first step toward developing a robust crystallization protocol. As a dipeptide composed of glycine and serine, it exhibits characteristics of both amino acids.

Property	Value/Information	Significance for Crystallization
Molecular Formula	C ₅ H ₁₀ N ₂ O ₄	Influences molecular weight and packing.
Molecular Weight	162.14 g/mol	Affects dissolution and diffusion rates.
Appearance	White to off-white solid	A baseline for assessing purity.
Melting Point	~207 °C	Important for thermal methods and assessing purity.
Solubility	Slightly soluble in water; limited solubility in organic solvents. Solubility is pH-dependent.	Critical for solvent selection and supersaturation control. The zwitterionic nature means solubility is lowest near the isoelectric point (pI) and increases in acidic or basic conditions.
pKa	~2.98 (carboxyl group)	Dictates the charge state of the molecule at different pH values, significantly impacting solubility and intermolecular interactions.
Polymorphism	Like its constituent amino acid glycine, it is expected to exhibit polymorphism.	Different crystal forms will have different properties (solubility, stability, etc.). Controlling polymorphism is often a key challenge.

Glycyl-dl-serine's zwitterionic nature, arising from its amino and carboxylic acid groups, governs its solubility profile. This is a critical parameter to control during crystallization, as solubility is highly dependent on the pH of the solution[1].

Q2: Which crystallization methods are most suitable for Glycyl-dl-serine?

Several crystallization methods can be successfully employed for **Glycyl-dl-serine**, with the choice depending on the desired crystal attributes (size, purity, polymorphic form) and the scale of the experiment.

- **Cooling Crystallization:** This is a common and effective method for compounds like **Glycyl-dl-serine** that have a temperature-dependent solubility. A saturated solution at a higher temperature is slowly cooled to induce supersaturation and crystallization.
- **Anti-solvent Crystallization:** This technique is particularly useful given **Glycyl-dl-serine's** limited solubility in many organic solvents. An "anti-solvent" (a solvent in which the dipeptide is poorly soluble) is added to a solution of the dipeptide, reducing its solubility and causing it to crystallize[2].
- **Slow Evaporation:** A straightforward method for initial screening of crystallization conditions. A near-saturated solution is left undisturbed, and as the solvent slowly evaporates, the concentration of the dipeptide increases, leading to crystallization[3].
- **Vapor Diffusion:** A gentle method ideal for producing high-quality single crystals, often used in crystallography. A drop of the dipeptide solution is allowed to equilibrate with a larger reservoir of a precipitant solution via the vapor phase[4].

Q3: How does pH influence the crystallization of Glycyl-dl-serine?

The pH of the crystallization medium is arguably one of the most critical parameters to control for zwitterionic molecules like **Glycyl-dl-serine**. The pH determines the net charge of the dipeptide, which in turn affects its solubility and the intermolecular interactions that drive crystal formation.

- **At the Isoelectric Point (pI):** The molecule has a net neutral charge, leading to minimal repulsion between molecules and typically the lowest solubility. This is often the target pH for initiating crystallization.

- Below the pI (Acidic conditions): The amino group is protonated (-NH₃⁺), and the molecule carries a net positive charge. Solubility generally increases.
- Above the pI (Basic conditions): The carboxyl group is deprotonated (-COO⁻), and the molecule carries a net negative charge. Solubility also tends to increase.

Controlling the pH allows for precise manipulation of the supersaturation level, which is the driving force for crystallization. For **Glycyl-dl-serine**, a pH close to its predicted pI would be a logical starting point for crystallization experiments. Studies on glycine have shown that adjusting the pH can even influence the resulting polymorphic form[1].

Q4: What is the role of seeding in Glycyl-dl-serine crystallization?

Seeding is a powerful technique to control the outcome of a crystallization process. It involves introducing small crystals of the desired material (seeds) into a supersaturated solution.

- Induces Crystallization: Seeding can initiate crystallization in a metastable zone where spontaneous nucleation is unlikely.
- Controls Polymorphism: By seeding with a specific polymorphic form, you can often direct the crystallization to produce that same form.
- Improves Crystal Size Distribution: Seeding can lead to a more uniform crystal size by providing a controlled number of nucleation sites, favoring crystal growth over new nucleation[5].
- Enhances Reproducibility: Seeding can make crystallization processes more consistent and reproducible from batch to batch.

The amount and size of the seed crystals are critical parameters that need to be optimized for each specific process[5].

Troubleshooting Guide

Problem 1: No crystals are forming.

This is a common issue and usually indicates that the solution is not sufficiently supersaturated.

Possible Cause	Scientific Explanation	Troubleshooting Steps
Insufficient Supersaturation	The concentration of Glycyl-dl-serine is below the solubility limit at the current conditions.	<ol style="list-style-type: none">1. Increase Concentration: If using cooling or anti-solvent methods, start with a more concentrated solution.2. Evaporate Solvent: For slow evaporation, allow more solvent to evaporate to increase the solute concentration.3. Adjust pH: Move the pH closer to the isoelectric point to decrease solubility.4. Add More Anti-solvent: In anti-solvent crystallization, a higher ratio of anti-solvent to solvent will further decrease solubility.
Metastable Zone is Too Wide	The solution is in a metastable state where crystal growth can occur, but spontaneous nucleation is kinetically hindered.	<ol style="list-style-type: none">1. Introduce a Seed Crystal: This is the most effective way to induce crystallization in a metastable solution.2. Scratch the Inner Surface: Use a glass rod to create microscopic imperfections on the vessel surface, which can act as nucleation sites.3. Thermal Shock: Briefly cool the solution to a much lower temperature to induce nucleation, then return it to the desired growth temperature.
Presence of Inhibiting Impurities	Certain impurities can interfere with the nucleation process by adsorbing to the surface of forming crystal nuclei.	<ol style="list-style-type: none">1. Purify the Starting Material: Use techniques like recrystallization or chromatography to improve the purity of the Glycyl-dl-serine.2.

Change the Solvent: A different solvent may reduce the solubility of the impurity or alter its interaction with the dipeptide.

Problem 2: An oil or amorphous precipitate forms instead of crystals.

"Oiling out" or precipitation occurs when the supersaturation is too high, leading to a rapid, disordered separation of the solute from the solution rather than an ordered crystal lattice formation.

Possible Cause	Scientific Explanation	Troubleshooting Steps
Excessive Supersaturation	The rate of supersaturation generation is too fast, exceeding the capacity for orderly molecular arrangement into a crystal lattice.	<ol style="list-style-type: none">1. Slow Down the Process: For cooling crystallization, decrease the cooling rate. For anti-solvent crystallization, add the anti-solvent more slowly and with good mixing.2. Reduce Initial Concentration: Start with a more dilute solution.3. Increase Crystallization Temperature: A higher temperature may favor slower, more controlled crystal growth.
Inappropriate Solvent System	The solvent may have too strong an interaction with the solute, preventing proper crystal packing.	<ol style="list-style-type: none">1. Experiment with Different Solvents/Anti-solvents: A solvent system with slightly lower solvating power for Glycyl-dl-serine may be beneficial.2. Adjust Solvent/Anti-solvent Ratio: Use a lower proportion of anti-solvent to reduce the initial supersaturation shock.
Impurities Lowering the Melting Point	Impurities can create a eutectic mixture with a lower melting point than the pure compound, leading to the separation of a liquid phase.	<ol style="list-style-type: none">1. Improve Purity: As with the failure to crystallize, purifying the starting material is crucial.

Problem 3: The crystals are too small, needle-like, or of poor quality.

The formation of many small crystals or undesirable crystal habits (like needles) is often a result of a high nucleation rate relative to the crystal growth rate.

Possible Cause	Scientific Explanation	Troubleshooting Steps
High Nucleation Rate	The conditions favor the formation of many new crystal nuclei rather than the growth of existing ones.	<ol style="list-style-type: none">1. Lower Supersaturation: Operate in a lower supersaturation regime by adjusting concentration, cooling rate, or anti-solvent addition rate.2. Use Seeding: Introduce a controlled number of seed crystals to promote growth on existing surfaces.3. Increase Temperature: A slightly higher temperature can sometimes favor growth over nucleation.
Solvent Effects on Crystal Habit	The solvent can preferentially adsorb to certain crystal faces, inhibiting their growth and leading to anisotropic crystal shapes like needles.	<ol style="list-style-type: none">1. Change the Solvent or Additives: Experiment with different solvents or small amounts of additives that can modify the crystal habit.2. Control pH: The pH can influence which crystal faces are more charged and thus interact more strongly with polar solvents.
Presence of Impurities	Impurities can selectively adsorb to specific crystal faces, altering their growth rates and leading to changes in crystal morphology[6].	<ol style="list-style-type: none">1. Purify the Material: High purity is essential for growing high-quality crystals.2. Characterize Impurities: If possible, identify the impurities to understand their potential interactions with the growing crystals.

Experimental Protocols

Protocol 1: Cooling Crystallization of Glycyl-dl-serine

This protocol is a starting point and should be optimized for your specific experimental setup and desired crystal characteristics.

- Dissolution:
 - In a clean crystallization vessel equipped with a magnetic stirrer, add a known amount of **Glycyl-dl-serine** to deionized water.
 - Heat the solution while stirring to a temperature where all the solid dissolves (e.g., 60-70 °C). Start with a concentration that is known to be soluble at the higher temperature but supersaturated at the lower temperature.
- Cooling:
 - Once fully dissolved, filter the hot solution through a pre-warmed filter to remove any insoluble impurities.
 - Allow the solution to cool slowly and undisturbed. A controlled cooling rate (e.g., 5-10 °C/hour) is often preferable to rapid cooling. An insulated container can be used to slow down the cooling process.
- Crystal Growth:
 - As the solution cools, crystals should start to form. Allow the crystallization to proceed for several hours or overnight at the final temperature (e.g., room temperature or 4 °C).
- Harvesting:
 - Collect the crystals by vacuum filtration.
 - Wash the crystals with a small amount of cold deionized water or a mixture of water and a miscible anti-solvent (e.g., ethanol) to remove any residual mother liquor.
 - Dry the crystals under vacuum at a moderate temperature.

Protocol 2: Anti-solvent Crystallization of Glycyl-dl-serine

This method is effective for inducing crystallization when cooling alone is insufficient.

- Solution Preparation:
 - Dissolve the **Glycyl-dl-serine** in a minimal amount of a suitable solvent (e.g., deionized water) at room temperature to create a concentrated solution.
- Anti-solvent Addition:
 - Slowly add a miscible anti-solvent (e.g., ethanol, isopropanol, or acetone) to the stirred dipeptide solution. The anti-solvent should be added dropwise to avoid generating excessively high local supersaturation.
 - The optimal solvent-to-anti-solvent ratio needs to be determined experimentally, but a starting point could be a 1:2 to 1:5 ratio (v/v) of solvent to anti-solvent.
- Crystallization and Harvesting:
 - After the addition of the anti-solvent, continue stirring for a period to allow for crystal growth.
 - Collect, wash, and dry the crystals as described in the cooling crystallization protocol. The wash solvent should be rich in the anti-solvent to minimize dissolution of the product.

Protocol 3: Seeding Protocol

Seeding can be incorporated into either the cooling or anti-solvent crystallization methods.

- Seed Preparation:
 - Obtain or prepare a small quantity of high-quality **Glycyl-dl-serine** crystals to use as seeds. If necessary, gently grind the seeds to a fine, uniform powder.
- Seeding Slurry:

- Prepare a slurry of the seed crystals in a small amount of the mother liquor or a solvent mixture that is saturated with **Glycyl-dl-serine** at the seeding temperature. This helps to ensure the seeds are well-dispersed and do not dissolve upon addition.
- Introducing the Seeds:
 - In a cooling crystallization, add the seed slurry once the solution has cooled into the metastable zone (i.e., below the saturation temperature but before spontaneous nucleation occurs).
 - In an anti-solvent crystallization, the seeds can be added just before or during the initial stages of anti-solvent addition.
- Controlled Growth:
 - After seeding, maintain the conditions (slow cooling or slow anti-solvent addition) to promote the growth of the seed crystals rather than the formation of new nuclei.

Visualization of Workflows

Troubleshooting Workflow for Crystallization Failure

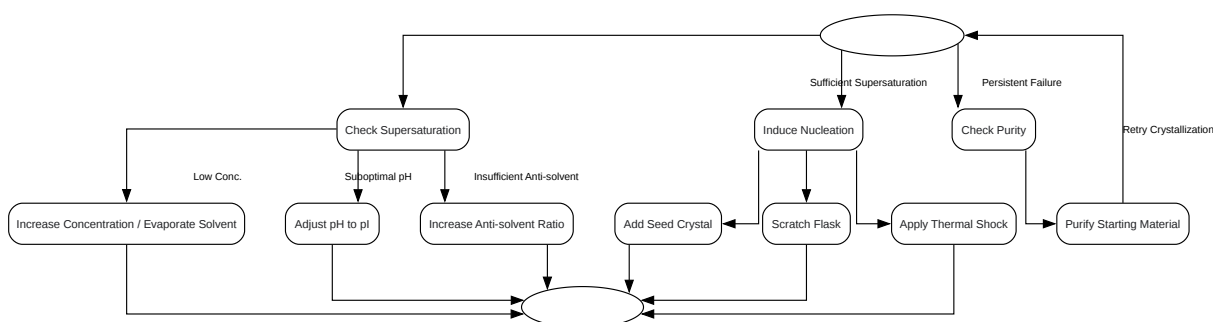

[Click to download full resolution via product page](#)

Caption: A logical workflow for troubleshooting the failure of crystal formation.

General Crystallization Workflow

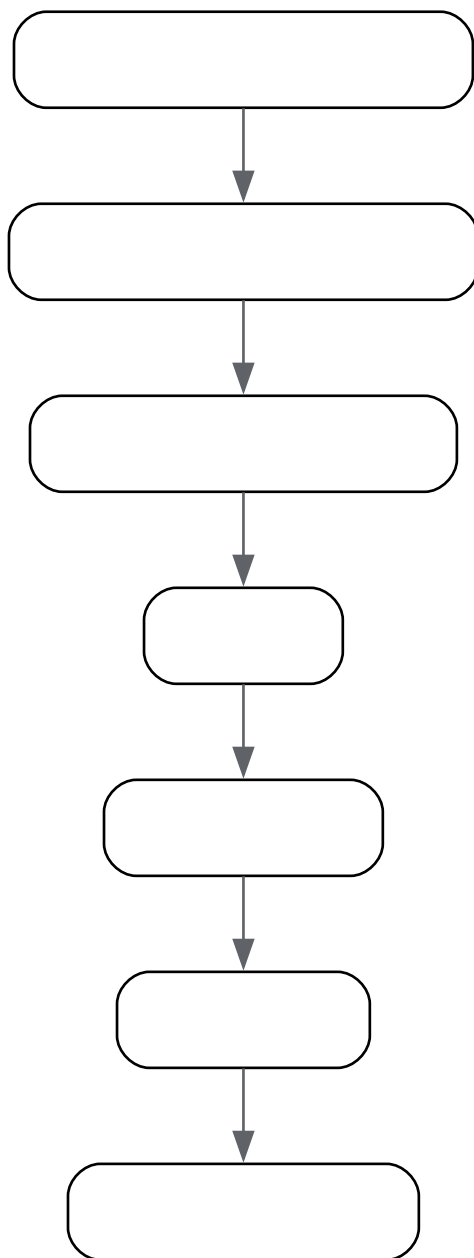

[Click to download full resolution via product page](#)

Caption: A generalized workflow for a typical crystallization experiment.

References

- Spingler, B., Schnidrig, S., Todorova, T., & Wild, F. (2012). Some thoughts about the single crystal growth of small molecules. *CrystEngComm*, 14(751-757). [\[Link\]](#)
- Cambrex. (n.d.). Crystallization process development: Peptide crystallization. [\[Link\]](#)
- Ciplukan, L. T., et al. (2017). Rapid Continuous Antisolvent Crystallization of Multicomponent Systems. *Crystal Growth & Design*, 17(12), 6514-6521. [\[Link\]](#)
- LifeTein. (n.d.). Peptide Crystallization Service. [\[Link\]](#)
- University of Geneva. (n.d.). Guide for crystallization. [\[Link\]](#)
- Shribak, A. A., et al. (2023). Features of the crystallization of multicomponent solutions: a dipeptide, its salt and potassium carbonate. *CrystEngComm*, 25(2), 258-270. [\[Link\]](#)
- Sibanda, J., Chivavava, J., & Lewis, A. E. (2022). Crystal Engineering in Antisolvent Crystallization of Rare Earth Elements (REEs). *Crystals*, 12(12), 1783. [\[Link\]](#)
- Staples, R. J. (2024). Getting crystals your crystallographer will treasure: a beginner's guide. *Acta Crystallographica Section E: Crystallographic Communications*, 80(4), 335-343. [\[Link\]](#)
- Organic Chemistry Lab at CU Boulder. (2021, September 24). Crystallization, Small Scale [Video]. YouTube. [\[Link\]](#)
- Decatur, S. M., & Gingras, Z. (2014). A Newcomer's Guide to Peptide Crystallography. *Biopolymers*, 102(4), 319-328. [\[Link\]](#)
- APC. (2024, September 18). Peptide Crystallization: Techniques, Challenges, and Solutions. [\[Link\]](#)
- Diamond Light Source. (n.d.). Crystal-seeding. [\[Link\]](#)
- Al-Zoubi, N. (2022). "Antisolvent Crystallization: A Novel Approach to Enhancement of Drug Bioavailability". *International Journal of Pharmaceutical Sciences Review and Research*, 75(2), 1-8. [\[Link\]](#)

- Singh, B., et al. (2020). FTIR, DSC and XRD analysis (a) FTIR spectra showing characteristic... [Image]. ResearchGate. [\[Link\]](#)
- ResearchGate. (2021). The best solvent for for dipeptide recrystallization? [Forum post]. [\[Link\]](#)
- Bitesize Bio. (2025, January 22). 5 Protein Crystallization Seeding Methods for Bigger Crystals. [\[Link\]](#)
- Mettler Toledo. (n.d.). Seeding Studies For Crystallization - Improve Batch Consistency. [\[Link\]](#)
- Gao, Q., et al. (2024). Impact of impurities on crystal growth. Nature, 628(8008), 555-561. [\[Link\]](#)
- AMRI. (n.d.). Protein and Peptide Crystallization. [\[Link\]](#)
- ResearchGate. (n.d.). The effects of impurities on crystal morphology formation: An experimental and molecular modelling investigation. [\[Link\]](#)
- Creative Biostructure. (n.d.). Peptide Crystallization. [\[Link\]](#)
- Hampton Research. (n.d.). Sample Preparation for Crystallization. [\[Link\]](#)
- Wang, S. L., & Chen, Y. F. (2018). ChemInform Abstract: Advances in Simultaneous DSC-FTIR Microspectroscopy for Rapid Solid State Chemical Stability Studies: Some Dipeptide Drugs as Examples. ChemInform, 49(32). [\[Link\]](#)
- Mustakis, J., et al. (2023). Prevalence of Impurity Retention Mechanisms in Pharmaceutical Crystallizations. Organic Process Research & Development, 27(4), 626-640. [\[Link\]](#)
- Kingston, R. L., & Baker, T. S. (2001). Crystallization of Macromolecules. Current protocols in molecular biology, Chapter 17, Unit 17.1. [\[Link\]](#)
- Schaller, T., et al. (2021). Investigation of Impurities in Peptide Pools. Molecules, 26(16), 4949. [\[Link\]](#)

- Grzesiak, A. L., & Lang, M. (2023). Structural Characterization of Pharmaceutical Cocrystals with the Use of Laboratory X-ray Powder Diffraction Patterns. *Crystals*, 13(4), 640. [[Link](#)]
- ResearchGate. (n.d.). Impact of impurities on crystal growth. [[Link](#)]
- ResearchGate. (n.d.). Analytical characterization a) FTIR spectra and b) DSC thermograms. [Image]. [[Link](#)]
- Sanchez-Weatherby, J., et al. (2023). A drug-discovery-oriented non-invasive protocol for protein crystal cryoprotection by dehydration, with application for crystallization screening. *Acta Crystallographica Section D: Structural Biology*, 79(Pt 6), 469-479. [[Link](#)]
- Ramachandran, E., & Natarajan, S. (2005). Crystal growth of some amino acids in gel: Crystallization of DL-serine and its characterization. *Indian Journal of Pure & Applied Physics*, 43(5), 372-376. [[Link](#)]
- Lee, E. H., & Heng, D. (2005). Glycine Crystallization during Spray Drying: The pH Effect on Salt and Polymorphic Forms. *Pharmaceutical research*, 22(6), 990-999. [[Link](#)]
- Piana, S., & Gale, J. D. (2005). Growth morphology of α -glycine crystals in solution environments: an extended interface structure analysis. *CrystEngComm*, 7(82), 503-508. [[Link](#)]
- Karabin, M., et al. (2018). DSC, FTIR and Raman Spectroscopy Coupled with Multivariate Analysis in a Study of Co-Crystals of Pharmaceutical Interest. *Molecules*, 23(9), 2139. [[Link](#)]
- Ranka, S., & Deamer, D. (2018). Racemic serine is less soluble than pure enantiomers due to stronger intermolecular hydrogen bonds. *bioRxiv*. [[Link](#)]
- ResearchGate. (n.d.). Uncovering a Hidden Polymorph of L-Serine through Additive-Mediated Crystallization. [[Link](#)]
- ResearchGate. (n.d.). Comparative Study on Solubility of Glycine, DL-alanine, DL-nor-valine and DL-serine in Aqueous Solutions of NaF and KF at 298.15 K. [[Link](#)]
- ResearchGate. (n.d.). (a–d) Photographs and computer-drawn morphology of glycyglycine... [Image]. [[Link](#)]

Need Custom Synthesis?

BenchChem offers custom synthesis for rare earth carbides and specific isotopic labeling.

Email: info@benchchem.com or [Request Quote Online](#).

Sources

- [1. researchgate.net](https://www.researchgate.net) [[researchgate.net](https://www.researchgate.net)]
- [2. ijprajournal.com](https://www.ijprajournal.com) [[ijprajournal.com](https://www.ijprajournal.com)]
- [3. creative-biostructure.com](https://www.creative-biostructure.com) [[creative-biostructure.com](https://www.creative-biostructure.com)]
- [4. benchchem.com](https://www.benchchem.com) [[benchchem.com](https://www.benchchem.com)]
- [5. mt.com](https://www.mt.com) [[mt.com](https://www.mt.com)]
- [6. researchgate.net](https://www.researchgate.net) [[researchgate.net](https://www.researchgate.net)]
- To cite this document: BenchChem. [Glycyl-dl-serine Crystallization Protocols: A Technical Support Guide]. BenchChem, [2026]. [Online PDF]. Available at: [<https://www.benchchem.com/product/b7782840/docs#glycyl-dl-serine-crystallization-protocols-a-technical-support-guide>]

Disclaimer & Data Validity:

The information provided in this document is for Research Use Only (RUO) and is strictly not intended for diagnostic or therapeutic procedures. While BenchChem strives to provide accurate protocols, we make no warranties, express or implied, regarding the fitness of this product for every specific experimental setup.

Technical Support: The protocols provided are for reference purposes. Unsure if this reagent suits your experiment?

Need Industrial/Bulk Grade? [Request Custom Synthesis Quote](#)

BenchChem

Our mission is to be the trusted global source of essential and advanced chemicals, empowering scientists and researchers to drive progress in science and industry.

Contact

Address: 3281 E Guasti Rd
Ontario, CA 91761, United States
Phone: (601) 213-4426
Email: info@benchchem.com

[Contact our Ph.D. Support Team for a compatibility check](#)