

functionalization of the 4-Chloro-6-phenyl-2,4'-bipyridine scaffold

Author: BenchChem Technical Support Team. **Date:** April 2026

Compound of Interest

Compound Name: 4-Chloro-6-phenyl-2,4'-bipyridine

Cat. No.: B7780479

[Get Quote](#)

Technical Application Note: Strategic Functionalization of the **4-Chloro-6-phenyl-2,4'-bipyridine** Scaffold

Executive Summary

The **4-Chloro-6-phenyl-2,4'-bipyridine** scaffold represents a specialized class of "Janus" ligands—molecules designed with dual, orthogonal reactivity profiles. Unlike the ubiquitous 2,2'-bipyridine which acts primarily as a chelate, the 2,4'-isomer structure enforces a divergent geometry. This scaffold is critical in the design of Metalloligands for Metal-Organic Frameworks (MOFs) and phosphorescent OLED emitters.

This guide details the functionalization of the C4-Chloro position, which serves as the electrophilic "handle" for tuning optoelectronic properties, while preserving the integrity of the C[^]N cyclometalating domain (Phenyl-Pyridine A) and the bridging domain (Pyridine B).

Structural Analysis & Reactivity Map

The molecule features three distinct reactive domains. Understanding their hierarchy is essential for sequential functionalization.

- Domain A (Electrophilic Handle): The C4-Chloro position on the central pyridine ring. It is activated for Palladium-catalyzed cross-coupling and Nucleophilic Aromatic Substitution ().
- Domain B (Cyclometalating Site): The 6-phenyl ring and the N1 nitrogen form a pocket capable of forming robust 5-membered metallacycles with Ir(III) or Pt(II).
- Domain C (Bridging Site): The 4'-pyridyl nitrogen is sterically unhindered and geometrically divergent, acting as a Lewis base for supramolecular assembly.

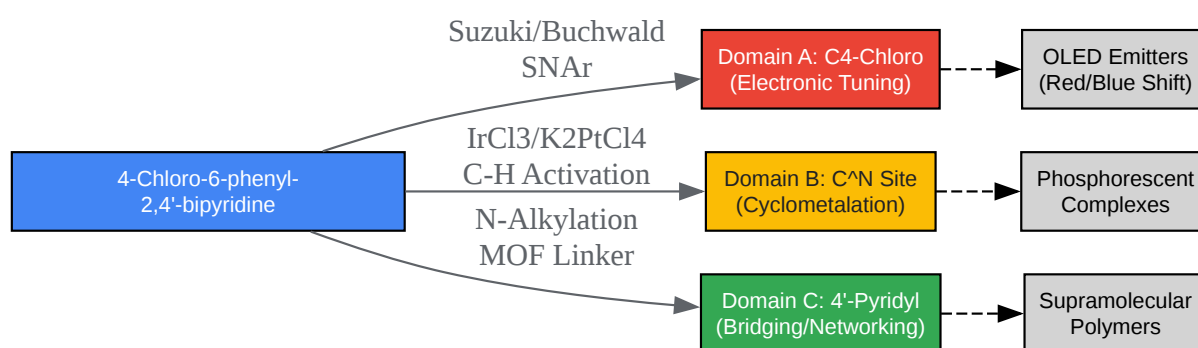

[Click to download full resolution via product page](#)

Figure 1: Orthogonal reactivity domains of the scaffold. The C4-Cl handle allows pre-complexation tuning of electronic states.

Module 1: Functionalization of the C4-Chloro Handle

The C4-position of pyridine is electron-deficient, making the chloride a viable leaving group. However, compared to 2-chloropyridine, the 4-isomer is less reactive toward

unless activated. Therefore, Palladium-catalyzed coupling is the preferred route for introducing carbon frameworks.

Protocol A: Suzuki-Miyaura Cross-Coupling (Arylation)

Purpose: To extend conjugation or introduce steric bulk, red-shifting the emission of subsequent metal complexes.

Reagents:

- Substrate: **4-Chloro-6-phenyl-2,4'-bipyridine** (1.0 equiv)
- Boronic Acid: Aryl-B(OH)
(1.2 equiv)
- Catalyst:
(5 mol%)
- Base:
(2.0 M aqueous, 3.0 equiv)
- Solvent: Toluene/Ethanol (3:1 v/v)

Step-by-Step Methodology:

- Degassing: In a Schlenk tube, combine the substrate, boronic acid, and solvent. Sparge with Argon for 15 minutes. Critical: Oxygen poisons the Pd(0) species, leading to homocoupling byproducts.
- Catalyst Addition: Add

and the aqueous base under a positive stream of Argon. Seal the vessel.
- Reaction: Heat to 90°C for 12–18 hours. Monitor by TLC (eluent: 5% MeOH in DCM). The starting material ($R_f \sim 0.4$) should disappear; the product is typically more fluorescent.
- Workup: Cool to RT. Dilute with Ethyl Acetate, wash with brine (), and dry over

.
- Purification: Flash column chromatography on silica gel. Gradient: 0%

5% MeOH in DCM.

Expert Insight: If the boronic acid is sterically hindered (e.g., mesityl), switch to

/ S-Phos catalyst system to boost oxidative addition rates [1].

Protocol B: Nucleophilic Aromatic Substitution ()

Purpose: To introduce alkoxy (-OR) or amino (-NR₂) donors, raising the HOMO energy and blue-shifting emission.

Reagents:

- Nucleophile: Sodium alkoxide (NaOR) formed in situ (NaH + alcohol).
- Solvent: Anhydrous DMF or DMSO.

Methodology:

- Dissolve the alcohol (1.5 equiv) in anhydrous DMF at 0°C.
- Add NaH (60% dispersion, 1.5 equiv) carefully. Stir 30 min until evolution ceases.
- Add the chlorobipyridine substrate (1.0 equiv).
- Heat to 100°C for 4–6 hours. Note: The 4-position requires higher thermal energy than the 2-position.
- Quench with water and extract into DCM.

Module 2: Cyclometalation (Synthesis of Iridium Dimers)

Once functionalized, the scaffold is converted into a photoactive Iridium(III) dimer. This protocol utilizes the "Nonoyama reaction" conditions.[1]

Mechanism: The Iridium center coordinates to the Nitrogen (N1) and activates the C-H bond of the 6-phenyl ring, forming a

-chloro bridged dimer.

Protocol:

- Stoichiometry: Combine (1.0 equiv) and the Ligand (2.2 equiv).
- Solvent: 2-Ethoxyethanol / Water (3:1 mixture). The water helps solubilize the inorganic chloride salt.
- Reflux: Heat to 110°C for 24 hours under Nitrogen.
- Precipitation: The product typically precipitates as a yellow/orange solid.
- Isolation: Cool, add water, and filter. Wash with water (to remove unreacted Ir) and diethyl ether (to remove excess ligand).
- Product: The resulting dimer is

.

QC Check (NMR):

- Look for the loss of the phenyl proton resonance at the activation site (usually the doublet at ~7.0–8.0 ppm disappears or shifts significantly).
- The bridging 4'-pyridyl protons should remain distinct and uncoordinated.

Data Summary & Troubleshooting

Issue	Observation	Root Cause	Solution
Low Yield (Suzuki)	Black precipitate (Pd black)	ingress or unstable ligand	Degas solvents longer; add TBAB (phase transfer)
No Reaction ()	SM recovered	4-Cl deactivation	Switch solvent to NMP; increase temp to 140°C
Insoluble Dimer	Precipitate won't dissolve for NMR	Bridging aggregation	Cleave dimer with acetylacetone (acac) or DMSO-d6

Downstream Applications (Why use this scaffold?)

- Metalloligands for MOFs: The free 4'-pyridyl group can bind to secondary metal nodes (Zn, Cd), incorporating the phosphorescent Iridium core into the backbone of a porous material.
- Sensors: The 4'-pyridyl nitrogen can be protonated or methylated (quaternized) to act as a pH sensor or electron acceptor (viologen-type), modulating the quenching of the Iridium emission [2].

References

- Suzuki-Miyaura Coupling of Chloropyridines
 - Title: Synthesis of Substituted 2,2'-Bipyridines from 2-Bromo- or 2-Chloropyridines Using Tetrakis(triphenylphosphine)palladium(0).
 - Source: Organic Chemistry Portal / Synthesis 2007.
 - URL:[[Link](#)]
- Cyclometalation Logic
 - Title: Cyclometalation of 6-Phenyl-2,2'-Bipyridine and Iridium: Synthesis, Characteriz
 - Source: Organometallics (ACS Public
 - URL:[[Link](#)]

- Bridging Ligand Behavior
 - Title: 2,2'-Bipyridine as both Bridging and Terminal Ligand in Binuclear Complexes.
 - Source: ResearchG
 - URL:[[Link](#)]
- General Reactivity of Halopyridines
 - Title: Dichotomy in Regioselectivity of SnAr Reactions with 2-MeSO₂-4-Chloropyrimidine. [2]
 - Source: WuXi AppTec / QM Magic Class.
 - URL:[[Link](#)]

Need Custom Synthesis?

BenchChem offers custom synthesis for rare earth carbides and specific isotopic labeling.

Email: info@benchchem.com or [Request Quote Online](#).

Sources

- 1. [mdpi.com](https://www.mdpi.com) [[mdpi.com](https://www.mdpi.com)]
- 2. Dichotomy in Regioselectivity of SnAr Reactions with 2-MeSO₂-4-Chloropyrimidine-Magical Power of Quantum Mechanics-Chemistry [chemistry.wuxiapptec.com]
- To cite this document: BenchChem. [functionalization of the 4-Chloro-6-phenyl-2,4'-bipyridine scaffold]. BenchChem, [2026]. [Online PDF]. Available at: [<https://www.benchchem.com/product/b7780479/docs#functionalization-of-the-4-chloro-6-phenyl-2-4-bipyridine-scaffold>]

Disclaimer & Data Validity:

The information provided in this document is for Research Use Only (RUO) and is strictly not intended for diagnostic or therapeutic procedures. While BenchChem strives to provide

accurate protocols, we make no warranties, express or implied, regarding the fitness of this product for every specific experimental setup.

Technical Support: The protocols provided are for reference purposes. Unsure if this reagent suits your experiment?

Need Industrial/Bulk Grade? [Request Custom Synthesis Quote](#)

BenchChem

Our mission is to be the trusted global source of essential and advanced chemicals, empowering scientists and researchers to drive progress in science and industry.

Contact

Address: 3281 E Guasti Rd

Ontario, CA 91761, United States

Phone: (601) 213-4426

Email: info@benchchem.com

[Contact our Ph.D. Support Team for a compatibility check](#)