

Technical Support Center: Troubleshooting Poor Response to MRT-10 In Vitro

Author: BenchChem Technical Support Team. **Date:** April 2026

Compound of Interest

Compound Name:	MRT-10
CAS No.:	6384-24-3
Cat. No.:	B7773584

[Get Quote](#)

Welcome to the technical support center for **MRT-10**, a potent Smoothed (Smo) antagonist. This resource is designed for researchers, scientists, and drug development professionals to help troubleshoot and resolve common issues encountered during in vitro experiments with **MRT-10**.

Frequently Asked Questions (FAQs)

Q1: What is **MRT-10** and what is its mechanism of action?

A1: **MRT-10** is a small molecule antagonist of the Smoothed (Smo) receptor, a key component of the Hedgehog (Hh) signaling pathway.^[1] In the canonical Hh pathway, the binding of a Hedgehog ligand to its receptor, Patched (PTCH), alleviates the inhibition of PTCH on Smo. This allows Smo to transduce a signal that leads to the activation of the GLI family of transcription factors, which then regulate the expression of target genes involved in cell proliferation and survival. **MRT-10** acts by binding to the Smo receptor, preventing its activation and thereby inhibiting the downstream signaling cascade.^[1]

Q2: In which solvent should I dissolve **MRT-10** and what is the recommended storage?

A2: **MRT-10** is soluble in dimethyl sulfoxide (DMSO). For in vitro experiments, it is crucial to keep the final concentration of DMSO in the cell culture medium as low as possible, ideally below 0.1%, as higher concentrations can have cytotoxic effects on their own. It is recommended to prepare fresh dilutions of **MRT-10** in culture medium for each experiment. Stock solutions in DMSO should be stored at -20°C for short-term storage (up to 1 month) or -80°C for long-term storage (up to 6 months).[1] Acylthiourea compounds are generally reported to be stable to air and moisture.

Q3: My cells are not responding to **MRT-10** treatment. What are the possible reasons?

A3: There are several potential reasons for a poor response to **MRT-10**, which are detailed in the troubleshooting guide below. The main categories of issues include problems with the compound itself (e.g., degradation, precipitation), the experimental setup (e.g., incorrect concentration, inappropriate assay), or the cell line being used (e.g., lack of Hh pathway dependence, intrinsic or acquired resistance).

Q4: How can I confirm that the Hedgehog pathway is active in my cell line?

A4: Before initiating experiments with **MRT-10**, it is essential to confirm that your cell line has an active Hedgehog pathway. This can be done by measuring the basal expression levels of downstream target genes of the Hh pathway, such as *GLI1* and *PTCH1*, using quantitative real-time PCR (qPCR). High basal expression of these genes is indicative of an active pathway.

Troubleshooting Guide

This guide provides a structured approach to identifying and resolving potential issues leading to a poor response to **MRT-10** in your in vitro experiments.

Logical Troubleshooting Workflow

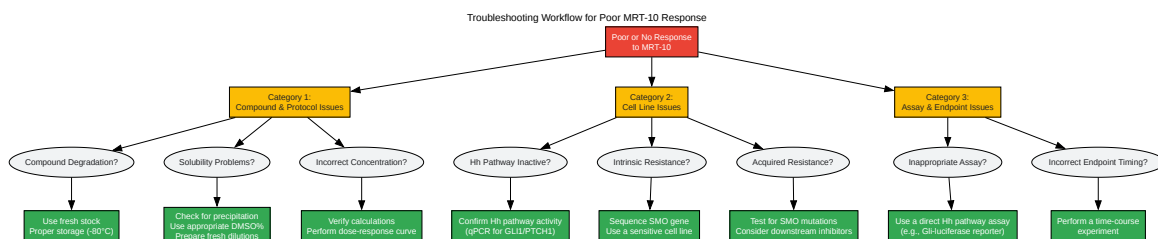

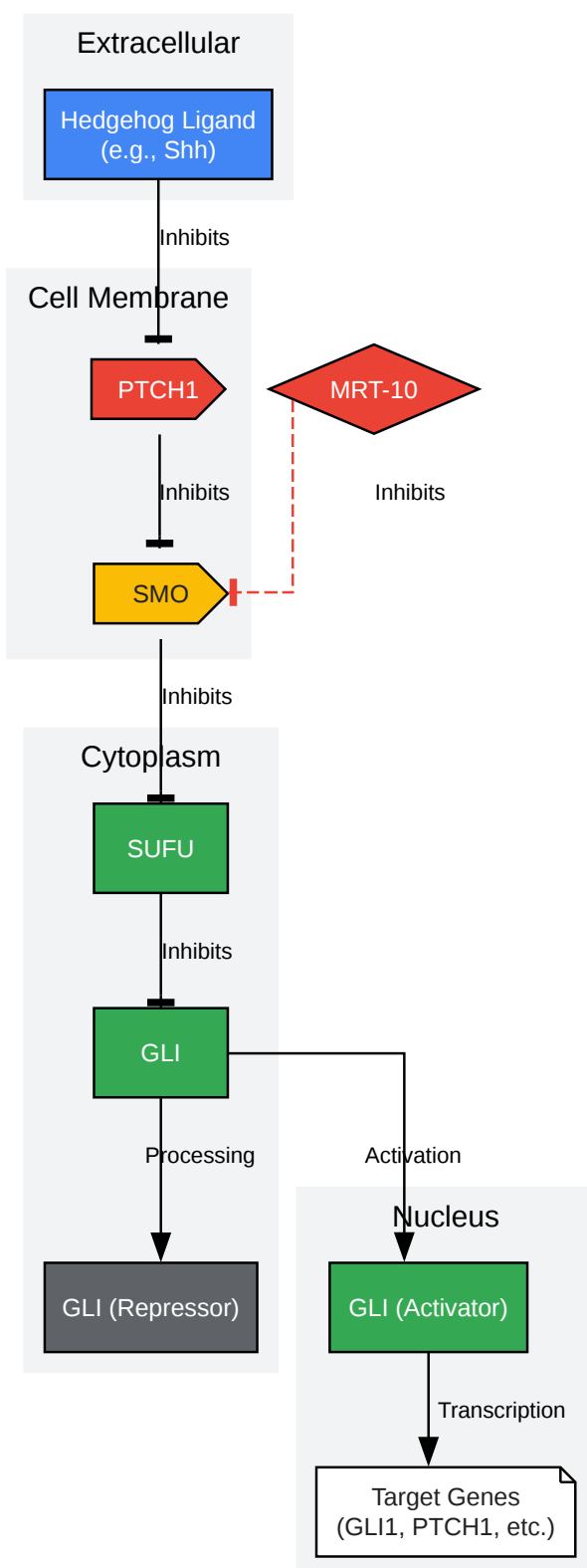

General Experimental Workflow for MRT-10 In Vitro

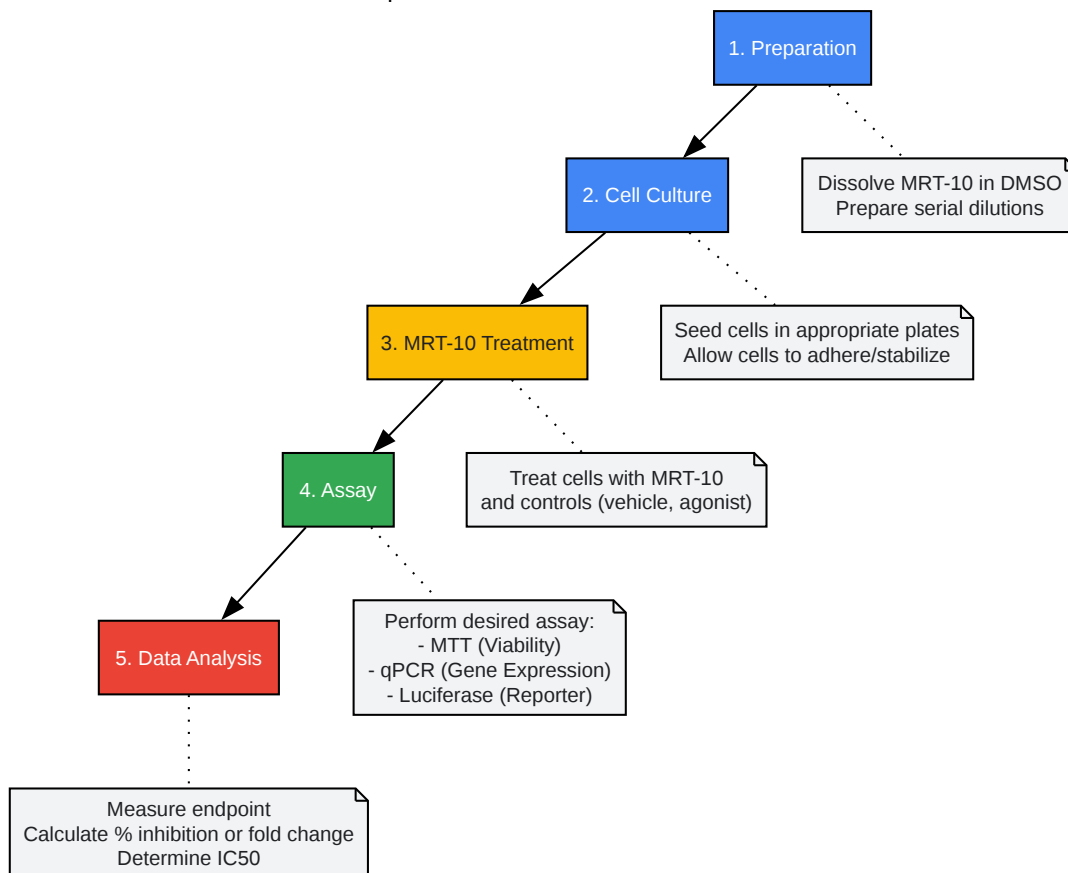

[Click to download full resolution via product page](#)

Need Custom Synthesis?

BenchChem offers custom synthesis for rare earth carbides and specific isotopic labeling.

Email: info@benchchem.com or [Request Quote Online](#).

References

- [1. researchgate.net \[researchgate.net\]](#)
- To cite this document: BenchChem. [Technical Support Center: Troubleshooting Poor Response to MRT-10 In Vitro]. BenchChem, [2026]. [Online PDF]. Available at: [\[https://www.benchchem.com/product/b7773584/docs#technical-support-center-troubleshooting-poor-response-to-mrt-10-in-vitro\]](https://www.benchchem.com/product/b7773584/docs#technical-support-center-troubleshooting-poor-response-to-mrt-10-in-vitro)

Disclaimer & Data Validity:

The information provided in this document is for Research Use Only (RUO) and is strictly not intended for diagnostic or therapeutic procedures. While BenchChem strives to provide accurate protocols, we make no warranties, express or implied, regarding the fitness of this product for every specific experimental setup.

Technical Support: The protocols provided are for reference purposes. Unsure if this reagent suits your experiment?

Need Industrial/Bulk Grade? [Request Custom Synthesis Quote](#)

BenchChem

Our mission is to be the trusted global source of essential and advanced chemicals, empowering scientists and researchers to drive progress in science and industry.

Contact

Address: 3281 E Guasti Rd
Ontario, CA 91761, United States
Phone: (601) 213-4426
Email: info@benchchem.com

[Contact our Ph.D. Support Team for a compatibility check](#)

