

Comparative Toxicology & Process Guide: N-Hydroxyphthalimide (NHPI) vs. N-Hydroxysuccinimide (NHS)

Author: BenchChem Technical Support Team. **Date:** April 2026

Compound of Interest

| | |
|----------------|--|
| Compound Name: | <i>N</i> -(Benzyloxycarbonyloxy)- phthalimide |
| CAS No.: | 65162-83-6 |
| Cat. No.: | B7771253 |

[Get Quote](#)

Executive Summary

The Verdict: While both reagents serve as effective mediators for oxidative catalysis and carboxyl activation, N-Hydroxysuccinimide (NHS) is the superior choice for late-stage pharmaceutical and bioconjugation applications due to its favorable safety profile and water-soluble byproducts. N-Hydroxyphthalimide (NHPI), while a more potent radical mediator (Ishii oxidation), presents significant downstream processing risks. Its byproduct, phthalimide, carries structural alerts for teratogenicity (thalidomide analog), exhibits higher cytotoxicity, and possesses poor water solubility that complicates purification.

Mechanistic Foundation & Chemical Distinction

To understand the toxicity profile, one must first understand the chemical fate of these reagents. Both compounds act as "sacrificial" activators, meaning they are converted 1:1 into their reduced imide byproducts during the reaction.

Structural Reactivity

- NHS (N-Hydroxysuccinimide): Primarily acts via ionic mechanisms (nucleophilic attack). It forms an active ester that is susceptible to aminolysis, releasing Succinimide.
- NHPI (N-Hydroxyphthalimide): Operates via two distinct pathways:
 - Ionic: Similar to NHS (active esters).
 - Radical: Generates the Phthalimide-N-oxyl (PINO) radical. This is a potent hydrogen atom abstractor (Bond Dissociation Energy ~88 kcal/mol), making it effective for aerobic oxidations but generating Phthalimide as the spent mediator.

Byproduct Generation Pathway

The following diagram illustrates the parallel pathways where the "Leaving Group" becomes the "Toxic Byproduct."

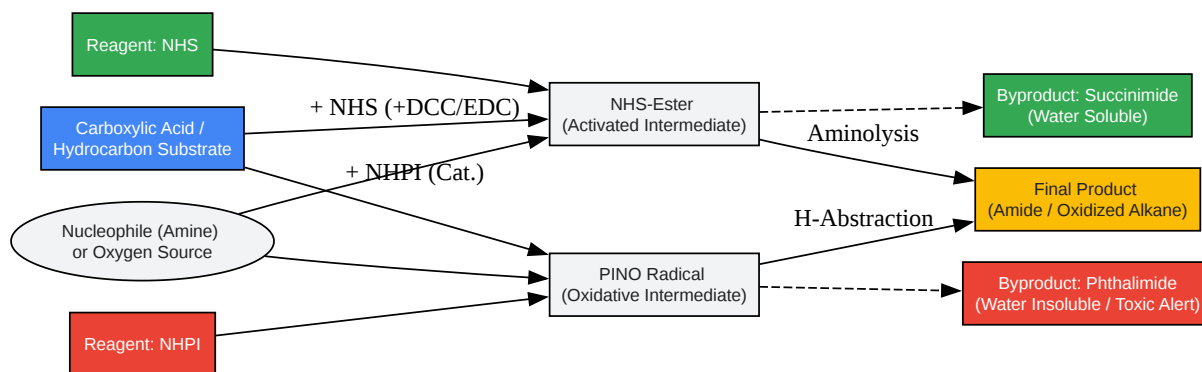

[Click to download full resolution via product page](#)

Figure 1: Mechanistic divergence showing the generation of Succinimide vs. Phthalimide.

Toxicological Profile: The Deep Dive

This section analyzes the byproducts, as the parent reagents are rarely the final contaminant.

Genotoxicity & Mutagenicity (Ames Test)

- Succinimide: Consistently tests Negative in Ames bacterial reverse mutation assays (strains TA98, TA100, TA1535). It is not considered mutagenic.[1][2]
- Phthalimide: Generally tests Negative in standard Ames assays (OECD TG 471). However, derivatives of phthalimide have shown DNA intercalation capabilities in specific assays, though the parent molecule is not classified as a mutagen.

Cytotoxicity & Cellular Viability

This is the primary differentiator. Phthalimide exhibits a more aggressive cytotoxic profile compared to the relatively benign succinimide.

| Metric | Succinimide (NHS Byproduct) | Phthalimide (NHPI Byproduct) |
|-----------------------|--|--|
| Cellular Target | Low affinity; pharmacophore in anticonvulsants (e.g., Ethosuximide). | High affinity for hydrophobic pockets; structural similarity to Thalidomide. |
| In Vitro Cytotoxicity | Low.[1] High concentrations (>mM range) required to inhibit cell growth. | Moderate to High. Significant inhibition of DNA synthesis in leukemia lines (L1210) [1]. |
| Mechanism of Action | Osmotic stress at high loads; generally metabolically inert. | Inhibition of DNA polymerase alpha and dihydrofolate reductase [1].[3] |
| Structural Alert | None. | Teratogenicity Alert. The phthalimide pharmacophore is the core of Thalidomide. |

Systemic Toxicity (Rodent Models)

- Succinimide: Low acute toxicity.[4] Used clinically in gram-quantities for epilepsy treatment (Ethosuximide), indicating the body can metabolize/excrete the succinimide ring safely.

- Phthalimide: LD50 (Oral, Rat) is ~5000 mg/kg. While acute lethality is low, repeated dose toxicity studies indicate liver and kidney stress due to difficult clearance.

Process Safety & Purification (The "Solubility Trap")

For drug development professionals, toxicity is a function of retention. If you cannot remove the byproduct, its toxicity becomes a critical quality attribute (CQA).

The Solubility Gap

- NHS/Succinimide: Highly soluble in water.[4][5] In bioconjugation, residual succinimide is removed via dialysis, desalting columns, or simple aqueous washing of the organic phase.
- NHPI/Phthalimide: Phthalimide has very poor water solubility (0.6 g/L at 20°C). It often co-precipitates with hydrophobic peptide/drug products.
 - Removal Challenge: Requires strong basic washes (hydrolysis risk to product) or hydrazine treatment (Gabriel synthesis workup), which introduces Hydrazine, a known carcinogen and genotoxin.

Decision Matrix: Reagent Selection

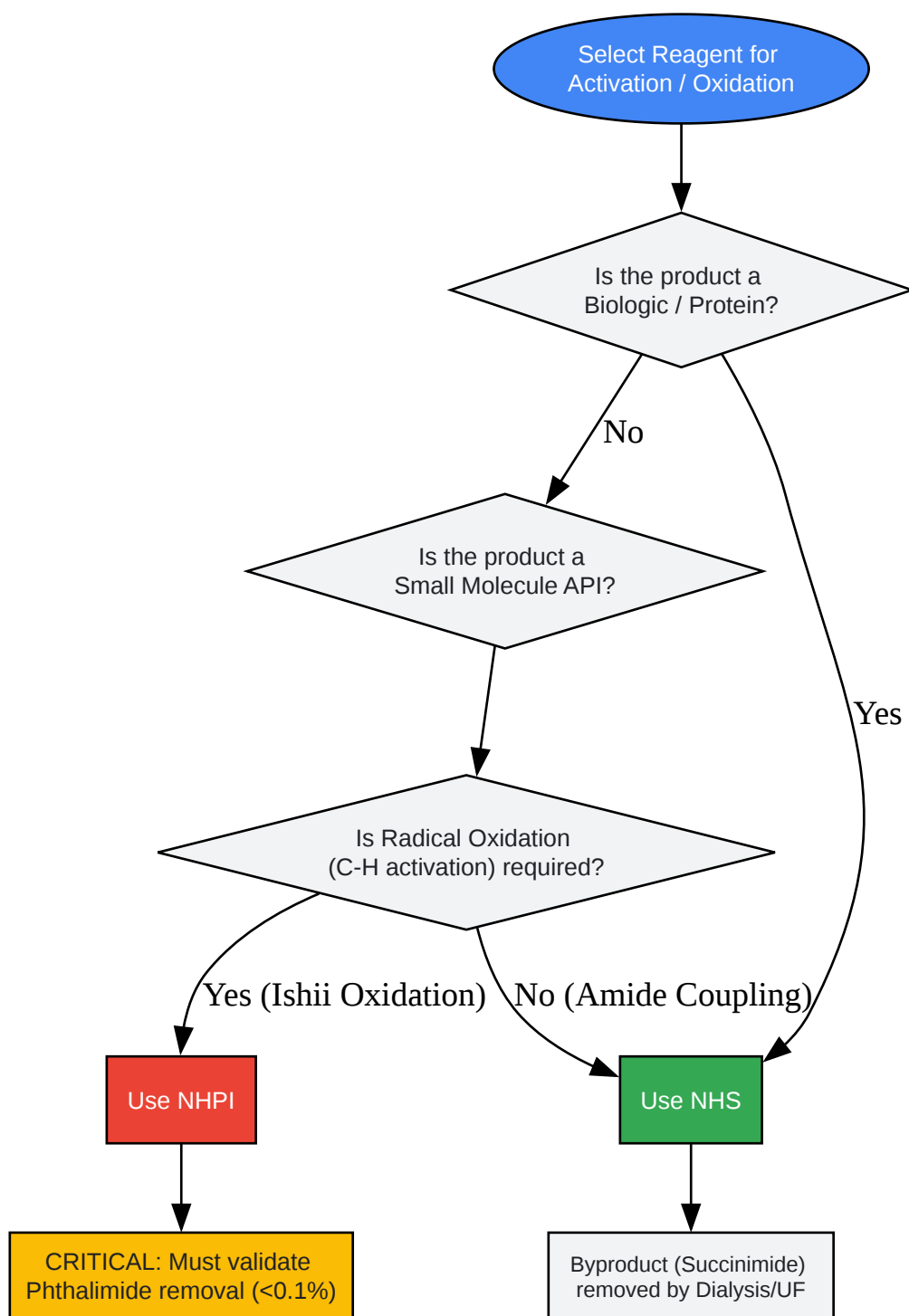

[Click to download full resolution via product page](#)

Figure 2: Selection workflow based on product type and removal capabilities.

Validated Experimental Protocols

These protocols are designed to validate the safety of your final product by quantifying residual byproducts.

Protocol A: HPLC Quantification of Residual Phthalimide

Use this to prove clearance of the toxic byproduct in small molecule APIs.

- Column: C18 Reverse Phase (e.g., Agilent Zorbax Eclipse Plus, 4.6 x 100 mm, 3.5 μ m).
- Mobile Phase:
 - A: 0.1% Phosphoric Acid in Water.
 - B: Acetonitrile.
 - Gradient: 10% B to 60% B over 15 minutes.
- Detection: UV at 220 nm (Phthalimide has strong absorbance here; Succinimide is weak/transparent at higher wavelengths).
- Standard Preparation: Dissolve Phthalimide standard in MeOH (1 mg/mL). Prepare serial dilutions down to 0.5 μ g/mL (LOD).
- Acceptance Criteria: Residual Phthalimide < 0.1% (w/w) relative to API, consistent with ICH M7 guidelines for potentially mutagenic/toxic impurities (if structural alerts are triggered).

Protocol B: Comparative Cytotoxicity Screen (MTT Assay)

Use this to assess the impact of reagent choice on sensitive biological systems.

- Cell Line: L929 (Murine Fibroblast) or CHO-K1 (Standard Pharma Host).
- Seeding: 10,000 cells/well in 96-well plate; incubate 24h at 37°C.
- Treatment:
 - Prepare stock solutions of NHS and NHPI (and their byproducts) in DMSO.

- Dilute in media to concentrations: 10, 50, 100, 500, 1000 μM .
- Apply to cells for 24 hours.
- Development:
 - Add MTT reagent (0.5 mg/mL). Incubate 4h.
 - Solubilize formazan crystals with DMSO.
 - Read Absorbance at 570 nm.
- Analysis: Calculate IC50.
 - Expected Result: Succinimide IC50 > 5000 μM (Non-toxic).
 - Expected Result: Phthalimide IC50 ~ 100-500 μM (Moderate Toxicity).

Comparative Data Summary

| Feature | N-Hydroxysuccinimide (NHS) | N-Hydroxyphthalimide (NHPI) |
|-------------------|-----------------------------------|--|
| Primary Use | Bioconjugation, Peptide Synthesis | Radical Oxidation (Ishii), Active Esters |
| Byproduct | Succinimide | Phthalimide |
| Water Solubility | High (Easy removal) | Very Low (Difficult removal) |
| Acute Toxicity | Low | Low to Moderate |
| Cytotoxicity | Low (IC50 > 5mM) | Moderate (IC50 ~100 μM) |
| Structural Alerts | None | Thalidomide-like core |
| Process Risk | Low (Dialysis/Washing) | High (Requires organic extraction/Hydrazine) |

References

- Hall, I. H., Wong, O. T., Scovill, J. P. (1995). The cytotoxicity of N-pyridinyl and N-quinolinyl substituted derivatives of phthalimide and succinimide.[3] *Biomedicine & Pharmacotherapy*, 49(5), 251-258.[3]
- OECD SIDS. (2006). Phthalimide: SIDS Initial Assessment Report for CoM. UNEP Publications.
- Hermanson, G. T. (2013). *Bioconjugate Techniques* (3rd ed.). Academic Press. (Chapter 3: Zero-Length Crosslinkers).
- Ishii, Y., et al. (1997). Alkane Oxidation with Molecular Oxygen Using N-Hydroxyphthalimide (NHPI) as a Key Catalyst. *Journal of Organic Chemistry*, 62(19), 6810-6828.
- EMA/ICH. (2014). ICH guideline M7(R1) on assessment and control of DNA reactive (mutagenic) impurities in pharmaceuticals.

Need Custom Synthesis?

BenchChem offers custom synthesis for rare earth carbides and specific isotopic labeling.

Email: info@benchchem.com or [Request Quote Online](#).

Sources

- 1. hvpchemicals.oecd.org [hvpchemicals.oecd.org]
- 2. medicilon.com [medicilon.com]
- 3. The cytotoxicity of N-Pyridinyl and N-quinolinyl substituted derivatives of phthalimide and succinimide - PubMed [pubmed.ncbi.nlm.nih.gov]
- 4. globallinker.com [globallinker.com]
- 5. taylorandfrancis.com [taylorandfrancis.com]
- To cite this document: BenchChem. [Comparative Toxicology & Process Guide: N-Hydroxyphthalimide (NHPI) vs. N-Hydroxysuccinimide (NHS)]. BenchChem, [2026]. [Online PDF]. Available at: [<https://www.benchchem.com/product/b7771253/docs#comparative-toxicology-process-guide-n-hydroxyphthalimide-nhpi-vs-n-hydroxysuccinimide-nhs>]

Disclaimer & Data Validity:

The information provided in this document is for Research Use Only (RUO) and is strictly not intended for diagnostic or therapeutic procedures. While BenchChem strives to provide accurate protocols, we make no warranties, express or implied, regarding the fitness of this product for every specific experimental setup.

Technical Support: The protocols provided are for reference purposes. Unsure if this reagent suits your experiment?

Need Industrial/Bulk Grade? [Request Custom Synthesis Quote](#)

BenchChem

Our mission is to be the trusted global source of essential and advanced chemicals, empowering scientists and researchers to drive progress in science and industry.

Contact

Address: 3281 E Guasti Rd
Ontario, CA 91761, United States
Phone: (601) 213-4426
Email: info@benchchem.com

[Contact our Ph.D. Support Team for a compatibility check](#)