

# Chiral Separation of Propranolol Enantiomers: Application Notes and Protocols

**Author:** BenchChem Technical Support Team. **Date:** April 2026

## Compound of Interest

Compound Name: *Propranolol*

CAS No.: 13013-17-7

Cat. No.: B7771359

[Get Quote](#)

For Researchers, Scientists, and Drug Development Professionals

This document provides detailed application notes and protocols for the chiral separation of **propranolol** enantiomers. **Propranolol**, a non-selective beta-blocker, is a racemic mixture of (S)-(-)-**propranolol** and (R)-(+)-**propranolol**. The (S)-enantiomer is known to be about 100 times more potent in its beta-blocking activity than the (R)-enantiomer, highlighting the critical need for effective enantioselective analytical methods in pharmaceutical research and development.

This guide covers three primary techniques for chiral separation: High-Performance Liquid Chromatography (HPLC), Supercritical Fluid Chromatography (SFC), and Capillary Electrophoresis (CE), providing detailed methodologies and comparative data to assist in method selection and implementation.

## High-Performance Liquid Chromatography (HPLC)

Direct chiral separation using chiral stationary phases (CSPs) is the most prevalent and robust method for resolving **propranolol** enantiomers. The selection of the appropriate CSP and

mobile phase is crucial for achieving optimal separation.

## Polysaccharide-Based Chiral Stationary Phases

Polysaccharide-based CSPs, particularly those derived from amylose and cellulose, are widely successful in separating a broad range of chiral compounds, including beta-blockers like **propranolol**.

Experimental Protocol: Chiral Separation using ChiralPak® IA

Objective: To achieve baseline separation of (R)- and (S)-**propranolol** enantiomers.

- Instrumentation: Standard HPLC system with UV detection.
- Column: ChiralPak® IA (amylose tris(3,5-dimethylphenylcarbamate) coated on silica gel), 250 x 4.6 mm, 5 µm.[1][2]
- Mobile Phase: n-heptane/ethanol/diethylamine (80/20/0.1, v/v/v).[1][2]
- Flow Rate: 1.0 mL/min.[1]
- Column Temperature: 25 °C.[1]
- Detection: UV at 230 nm.
- Sample Preparation: Dissolve **propranolol** hydrochloride in methanol to a concentration of 0.5 mg/mL.[1][2]

Procedure:

- Equilibrate the ChiralPak® IA column with the mobile phase until a stable baseline is achieved.
- Inject the prepared **propranolol** sample solution.
- Monitor the elution profile. The S(-)-isomer will elute first, followed by the R(+)-isomer.[1][2]

Quantitative Data Summary: HPLC with Polysaccharide-Based CSPs

Chiral Stationary Phase	Mobile Phase (v/v/v)	Flow Rate (mL/min)	Detection	R-propranolol Retention Time (tR)	S-propranolol Retention Time (tR)	Resolution (Rs)	Separation Factor ( $\alpha$ )	Reference
ChiralPak® IA	n-heptane/ethanol/diethylamine (80/20/0.1)	1.0	UV	5.264 min	4.708 min	1.75	-	[1][2]
Chiralcel OD-H	n-hexane-ethanol-ammonia (70:30:0.4)	0.4	MS/MS	-	-	Complete Separation	-	[3]
Lux Cellulose-1	n-hexane/ethanol/DEA (70/30/0.3)	1.0	DAD at 280 nm	-	-	-	-	[4]
Chirex 3022	hexane – dichloromethane – ethanol – trifluoro	2.0	UV	-	-	2.62	-	[5]

acetic  
acid (55  
+ 40 +  
5 +  
0.25)

---

Note: "-" indicates data not specified in the cited source.

## Protein-Based and Cyclodextrin-Based Chiral Stationary Phases

Protein-based CSPs, such as those utilizing  $\alpha$ -glycoprotein (AGP), and cyclodextrin-based CSPs (BCD) also offer effective chiral resolution of **propranolol**.[\[6\]](#)[\[7\]](#)[\[8\]](#)

Experimental Protocol: Chiral Separation using  $\alpha$ -Glycoprotein (AGP) CSP

Objective: To compare the chiral separation of **propranolol** using a protein-based CSP.

- Instrumentation: HPLC system with UV detection.
- Column: AGP chiral analytical column (150 mm X 4 mm X 5  $\mu$ m).[\[6\]](#)[\[8\]](#)
- Mobile Phase: Isopropanol/Ammonium acetate (0.5:99.5 v/v).[\[6\]](#)[\[8\]](#)
- Flow Rate: 0.9 mL/min.[\[6\]](#)[\[8\]](#)
- Column Temperature: Ambient.[\[6\]](#)
- Detection: UV at 225 nm.[\[6\]](#)[\[8\]](#)
- Sample Preparation: Dissolve 10 mg of **propranolol** hydrochloride in 10 mL of methanol.[\[6\]](#)  
[\[7\]](#)

Experimental Protocol: Chiral Separation using  $\beta$ -Cyclodextrin (BCD) CSP

Objective: To evaluate the chiral separation of **propranolol** using a cyclodextrin-based CSP.

- Instrumentation: HPLC system with UV detection.

- Column: BCD chiral analytical column (200 mm X 4 mm X 5  $\mu$ m).[6]
- Mobile Phase: Acetonitrile/Ethanol/Acetic acid/Triethylamine (960:33:4:3 v/v/v/v).[6]
- Flow Rate: 1.0 mL/min.[6]
- Column Temperature: Ambient.[6]
- Detection: UV at 225 nm.[6]
- Sample Preparation: Dissolve 10 mg of **propranolol** hydrochloride in 10 mL of methanol.[6]  
[7]

Quantitative Data Summary: HPLC with AGP and BCD CSPs

Chiral Stationary Phase	Mobile Phase	Flow Rate (mL/min)	R-propranolol Retention Time (tR)	S-propranolol Retention Time (tR)	Reference
$\alpha$ -Glycoprotein (AGP)	Isopropanol/Ammonium acetate (0.5:99.5 v/v)	0.9	11.82 min	7.25 min	[7][8][9]
$\beta$ -Cyclodextrin (BCD)	Acetonitrile/Ethanol/Acetic acid/Triethylamine (960:33:4:3 v/v/v/v)	1.0	18.50 min	16.18 min	[7][9]

## Supercritical Fluid Chromatography (SFC)

SFC has emerged as a powerful alternative to HPLC, offering advantages such as faster analysis times and reduced consumption of organic solvents.[10] This technique utilizes supercritical CO<sub>2</sub> as the primary mobile phase component.

## Experimental Protocol: Chiral Separation using Chiralpak® IG

Objective: To achieve rapid and efficient enantioseparation of **propranolol** using SFC.

- Instrumentation: SFC system with UV detection.
- Column: Chiralpak® IG (amylose tris(3-chloro-5-methylphenylcarbamate) immobilized on silica gel), 250 mm x 4.6 mm, 5 µm.[10][11]
- Mobile Phase: A mixture of CO<sub>2</sub> and (0.1% isopropyl amine in isopropanol:methanol (50:50, v/v)) in a 75:25 (v/v) ratio.[10][11]
- Flow Rate: 4.0 mL/min.[11]
- Column Temperature: 40 °C.[11]
- Backpressure: 100 bar.[11]
- Detection: UV at 220 nm.[11]
- Sample Preparation: Prepare stock solutions in the mobile phase co-solvent.

## Quantitative Data Summary: SFC with Chiralpak® IG

Chiral Stationary Phase	Mobile Phase	Resolution (Rs)	Separation Factor ( $\alpha$ )	Reference
Chiralpak® IG	CO <sub>2</sub> / (0.1% isopropyl amine in isopropanol:methanol (50:50)) (75:25)	> 3.0	> 1.5	[10]

## Capillary Electrophoresis (CE)

Capillary electrophoresis is another valuable technique for the enantioselective analysis of **propranolol**, often employing a chiral selector added to the running buffer.

Experimental Protocol: Chiral Separation using a Cyclodextrin Chiral Selector

Objective: To separate the enantiomers of **propranolol** using CE with a chiral selector.

- Instrumentation: Capillary electrophoresis system with UV detection.
- Capillary: Uncoated fused-silica capillary.[12]
- Running Electrolyte: 4% w/v carboxymethyl-beta-cyclodextrin in 25 mmol/L triethylamine/phosphoric acid buffer (pH 9).[12]
- Voltage: 17 kV.[12]
- Detection: UV at 208 nm.[12]

Procedure:

- Condition the capillary with the running electrolyte.
- Inject the sample by hydrodynamic or electrokinetic injection.
- Apply the separation voltage and monitor the electrophoretic profile.

## Experimental Workflow Diagrams

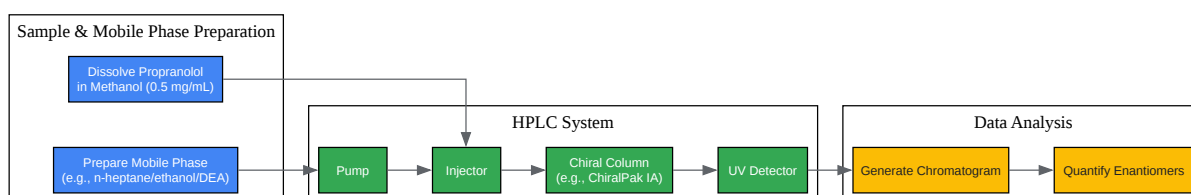

[Click to download full resolution via product page](#)

Caption: HPLC experimental workflow for chiral separation of **propranolol**.

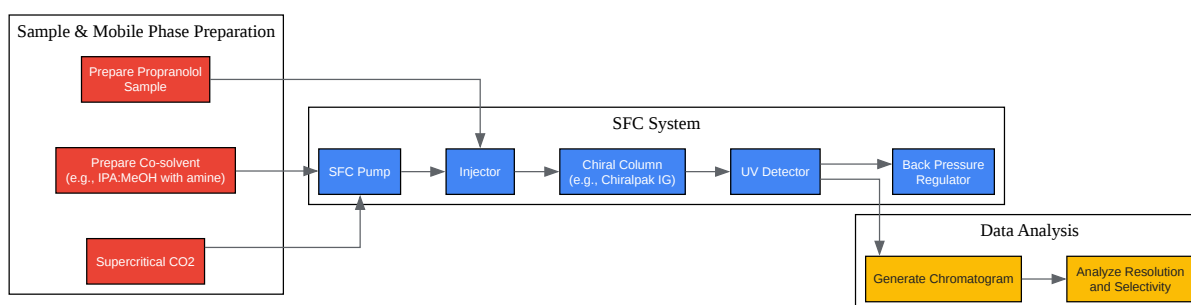

[Click to download full resolution via product page](#)

Caption: SFC experimental workflow for **propranolol** enantioseparation.

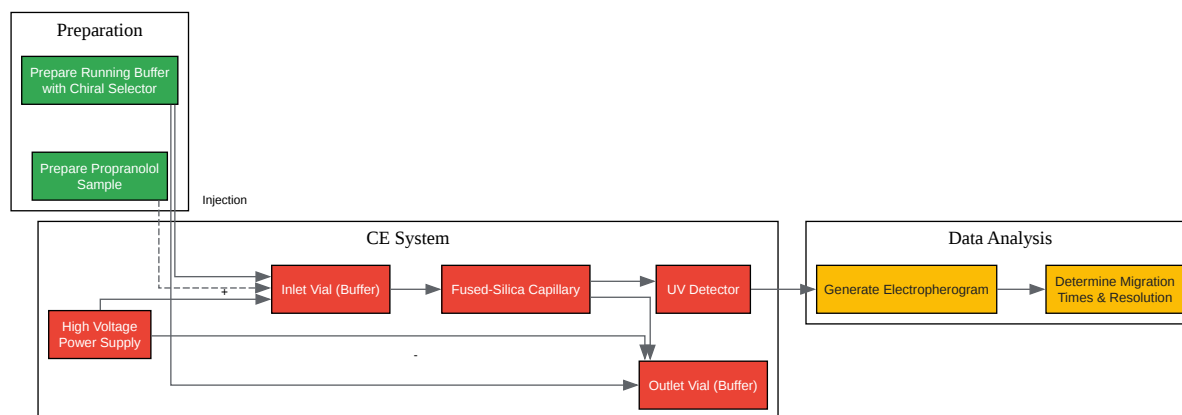

[Click to download full resolution via product page](#)

Caption: CE experimental workflow for chiral analysis of **propranolol**.

### Need Custom Synthesis?

BenchChem offers custom synthesis for rare earth carbides and specific isotopic labeling.

Email: [info@benchchem.com](mailto:info@benchchem.com) or [Request Quote Online](#).

## References

- 1. [researchgate.net](https://www.researchgate.net) [researchgate.net]
- 2. [scindeks-clanci.ceon.rs](https://scindeks-clanci.ceon.rs) [scindeks-clanci.ceon.rs]
- 3. [Enantiomeric separation of propranolol by normal phase chiral liquid chromatography coupled, with tandem mass spectrometry] - PubMed [pubmed.ncbi.nlm.nih.gov]

- 4. Comparative HPLC methods for  $\beta$ -blockers separation using different types of chiral stationary phases in normal phase and polar organic phase elution modes. Analysis of propranolol enantiomers in natural waters - PubMed [pubmed.ncbi.nlm.nih.gov]
- 5. abis-files.gazi.edu.tr [abis-files.gazi.edu.tr]
- 6. dspace.univ-eloued.dz [dspace.univ-eloued.dz]
- 7. media.neliti.com [media.neliti.com]
- 8. journal.univ-eloued.dz [journal.univ-eloued.dz]
- 9. researchgate.net [researchgate.net]
- 10. Simultaneous enantioseparation and simulation studies of atenolol, metoprolol and propranolol on Chiralpak® IG column using supercritical fluid chromatography - PMC [pmc.ncbi.nlm.nih.gov]
- 11. Simultaneous enantioseparation and simulation studies of atenolol, metoprolol and propranolol on Chiralpak® IG column using supercritical fluid chromatography - ProQuest [proquest.com]
- 12. benchchem.com [benchchem.com]
- To cite this document: BenchChem. [Chiral Separation of Propranolol Enantiomers: Application Notes and Protocols]. BenchChem, [2026]. [Online PDF]. Available at: [https://www.benchchem.com/product/b7771359/docs#chiral-separation-of-propranolol-enantiomers-application-notes-and-protocols]

---

#### Disclaimer & Data Validity:

The information provided in this document is for Research Use Only (RUO) and is strictly not intended for diagnostic or therapeutic procedures. While BenchChem strives to provide accurate protocols, we make no warranties, express or implied, regarding the fitness of this product for every specific experimental setup.

**Technical Support:** The protocols provided are for reference purposes. Unsure if this reagent suits your experiment?

**Need Industrial/Bulk Grade?** [Request Custom Synthesis Quote](#)

# BenchChem

Our mission is to be the trusted global source of essential and advanced chemicals, empowering scientists and researchers to drive progress in science and industry.

## Contact

Address: 3281 E Guasti Rd  
Ontario, CA 91761, United States  
Phone: (601) 213-4426  
Email: [info@benchchem.com](mailto:info@benchchem.com)

[Contact our Ph.D. Support Team for a compatibility check](#)