

# Application Notes & Protocols: The Role of 2-Hydroxyethyl Acetate in Modern Pharmaceutical Synthesis

**Author:** BenchChem Technical Support Team. **Date:** May 2026

## Compound of Interest

Compound Name: 2-Hydroxyethyl acetate

CAS No.: 65071-98-9

Cat. No.: B7771454

[Get Quote](#)

## Abstract

**2-Hydroxyethyl acetate**, also known as ethylene glycol monoacetate, is a bifunctional organic molecule featuring both a primary hydroxyl and an ester group.[1] This unique structural arrangement confers versatile solvency characteristics and makes it a valuable intermediate and reactant in the synthesis of pharmaceutical compounds.[1] Its ability to act as a polar aprotic solvent, a nucleophile via its hydroxyl group, and a precursor to more complex structures allows for its application in diverse synthetic strategies, including the formation of prodrugs, the synthesis of antiviral agents, and as a building block for heterocyclic scaffolds. This technical guide provides an in-depth exploration of the chemical properties, applications, and detailed protocols for the effective use of **2-hydroxyethyl acetate** in a research and drug development setting.

## Introduction: Understanding 2-Hydroxyethyl Acetate

**2-Hydroxyethyl acetate** (CAS 542-59-6) is the monoester of ethylene glycol and acetic acid. [1] Its bifunctionality is the cornerstone of its utility in pharmaceutical chemistry. The primary

hydroxyl group provides a reactive site for esterification, etherification, and other nucleophilic additions, while the acetate moiety influences its solubility and physical properties. It is a colorless, nearly odorless liquid that is soluble in water, alcohol, ether, and benzene.[1][2]

## Physicochemical Properties

The physical and chemical properties of **2-hydroxyethyl acetate** make it a predictable and reliable component in synthetic workflows. A summary of its key characteristics is presented below.

Property	Value	Reference
IUPAC Name	2-hydroxyethyl acetate	[1][3]
Synonyms	Ethylene glycol monoacetate, 2-Acetoxyethanol	[1][4]
Molecular Formula	C <sub>4</sub> H <sub>8</sub> O <sub>3</sub>	[1][3][5]
Molecular Weight	104.10 g/mol	[1][3]
Physical State	Colorless liquid	[1][2]
Boiling Point	182 °C (358-360 °F)	[3][6]
Melting Point	-45 °C	[6]
Density	1.106 - 1.109 g/mL at 20-25 °C	[3][7]
Solubility	Soluble in water, alcohol, ether, benzene	[2][8]
Flash Point	88 - 102 °C (190 - 215 °F)	[3][9]

## Synthesis Overview

The industrial synthesis of **2-hydroxyethyl acetate** is typically achieved through two primary routes:

- Fischer Esterification: This classic acid-catalyzed reaction involves the direct esterification of ethylene glycol with acetic acid.[1][10] While straightforward, this method is reversible and

can produce the byproduct ethylene glycol diacetate.[1]

- Transesterification: An alternative route involves the reaction of ethylene glycol with another acetate ester, such as sec-butyl acetate, in the presence of a catalyst.[11][12] This method can offer advantages in terms of reaction speed and ease of product separation.[11]

The choice of synthetic route often depends on the desired purity, scale, and economic considerations of the manufacturing process.

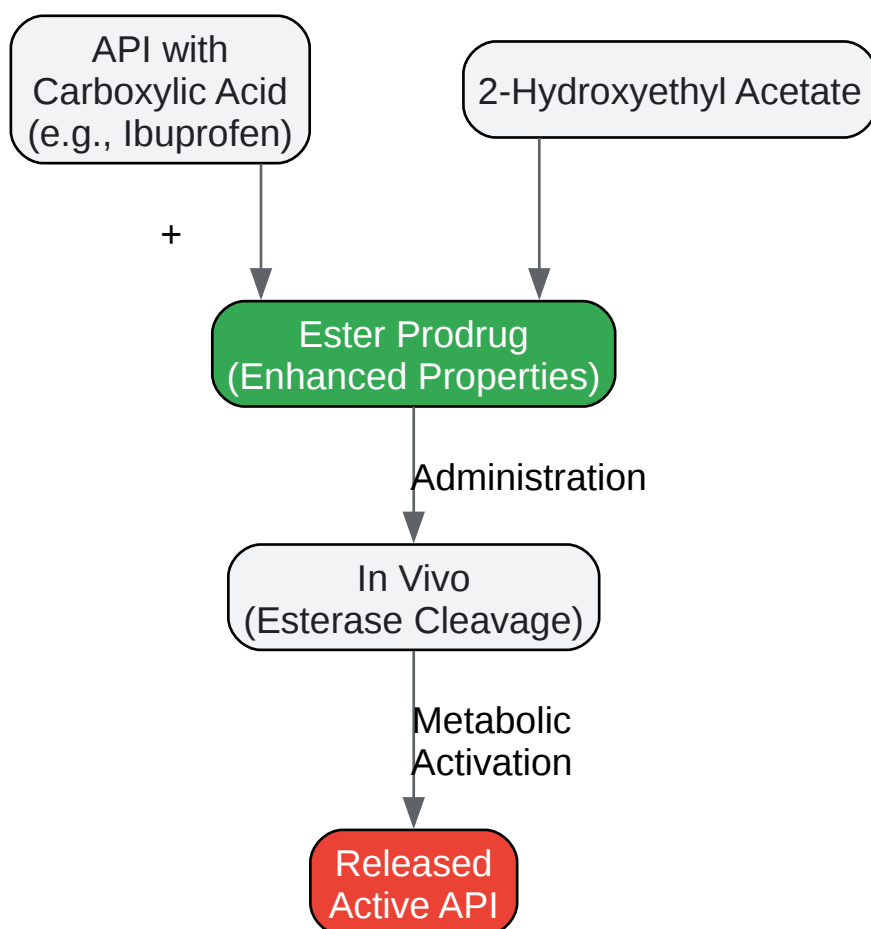
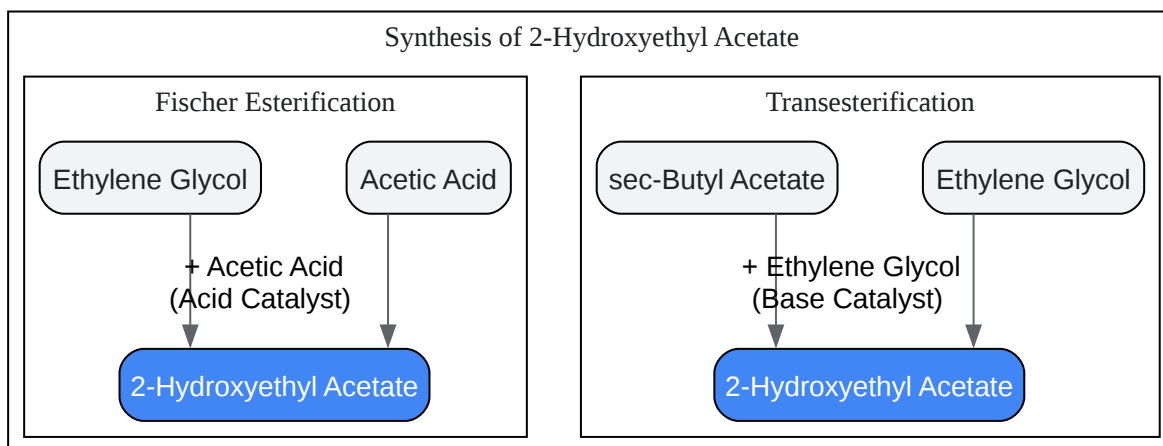

[Click to download full resolution via product page](#)

Caption: Conceptual workflow for prodrug synthesis using **2-hydroxyethyl acetate**.

## As a Building Block for Antiviral Agents

The structural backbone of **2-hydroxyethyl acetate** is a valuable synthon for constructing more complex molecules, particularly in the field of antiviral drug discovery. Research has shown that nucleoside analogues containing a 2'-(beta)-hydroxyethyl moiety can act as potent and selective inhibitors of viral replication. [13] Specifically, 2'-(beta)-hydroxyethylated adenosine has been identified as an inhibitor of the hepatitis C virus (HCV) RNA-dependent RNA polymerase (NS5B). [13] In these syntheses, the hydroxyethyl group is incorporated into the core structure to mimic or modify the ribose sugar of natural nucleosides, thereby disrupting viral polymerase activity. [13][14]

## As a Precursor in Heterocyclic Synthesis

**Heterocyclic compounds are fundamental to medicinal chemistry, with a vast majority of drugs containing at least one heterocyclic ring. [17][18][19][20] The bifunctional nature of 2-hydroxyethyl acetate allows it to serve as a versatile C2-O-C2 building block. The hydroxyl and acetate groups can be manipulated sequentially or in one pot to construct various oxygen-containing heterocycles, which are key scaffolds in many pharmacologically active molecules. [17]**

## Experimental Protocols

The following protocols are provided as a guide for researchers. All procedures should be conducted in a well-ventilated fume hood, and appropriate personal protective equipment (PPE) must be worn.

## Protocol 1: Synthesis of an Ibuprofen-Hydroxyethyl Ester Prodrug

This protocol is adapted from the synthesis of ibuprofen hydroxy ethyl ester and serves as a general model for the esterification of a carboxylic acid-containing API with **2-hydroxyethyl acetate**. [15] Objective: To synthesize the 2-hydroxyethyl ester of Ibuprofen via acid-catalyzed esterification.

### Materials:

- Ibuprofen (1.0 eq)
- **2-Hydroxyethyl acetate** (10.0 eq, serves as reactant and solvent)
- Boron trifluoride etherate ( $\text{BF}_3 \cdot \text{OEt}_2$ ) (catalyst, ~0.45 eq)
- Dichloromethane ( $\text{CH}_2\text{Cl}_2$ )
- Saturated aqueous sodium bicarbonate ( $\text{NaHCO}_3$ ) solution
- Anhydrous magnesium sulfate ( $\text{MgSO}_4$ ) or sodium sulfate ( $\text{Na}_2\text{SO}_4$ )
- Silica gel for column chromatography
- Eluent: Benzene and Ethyl Acetate (2:1 v/v) (Note: Benzene is a known carcinogen; consider substituting with a less hazardous solvent like toluene if the separation profile allows).

### Procedure:

- **Reaction Setup:** To a round-bottom flask equipped with a magnetic stirrer and reflux condenser, add ibuprofen (1.0 eq) and **2-hydroxyethyl acetate** (10.0 eq).
- **Catalyst Addition:** Carefully add freshly distilled boron trifluoride etherate (~0.45 eq) to the mixture.
- **Reaction:** Heat the reaction mixture to 100°C and maintain for 14-16 hours. Monitor the reaction progress using Thin Layer Chromatography (TLC).

- Work-up:
  - Allow the reaction mixture to cool to room temperature.
  - Partition the mixture between dichloromethane ( $\text{CH}_2\text{Cl}_2$ ) and a saturated aqueous  $\text{NaHCO}_3$  solution in a separatory funnel. This step neutralizes the acidic catalyst.
  - Separate the organic layer.
  - Wash the organic layer sequentially with saturated  $\text{NaHCO}_3$  solution and brine.
- Drying and Concentration: Dry the organic layer over anhydrous  $\text{MgSO}_4$  or  $\text{Na}_2\text{SO}_4$ , filter, and concentrate the solvent under reduced pressure using a rotary evaporator.
- Purification: Purify the resulting crude residue by silica gel column chromatography using the specified eluent system to yield the pure hydroxyethyl ester of ibuprofen. [[15](#)]

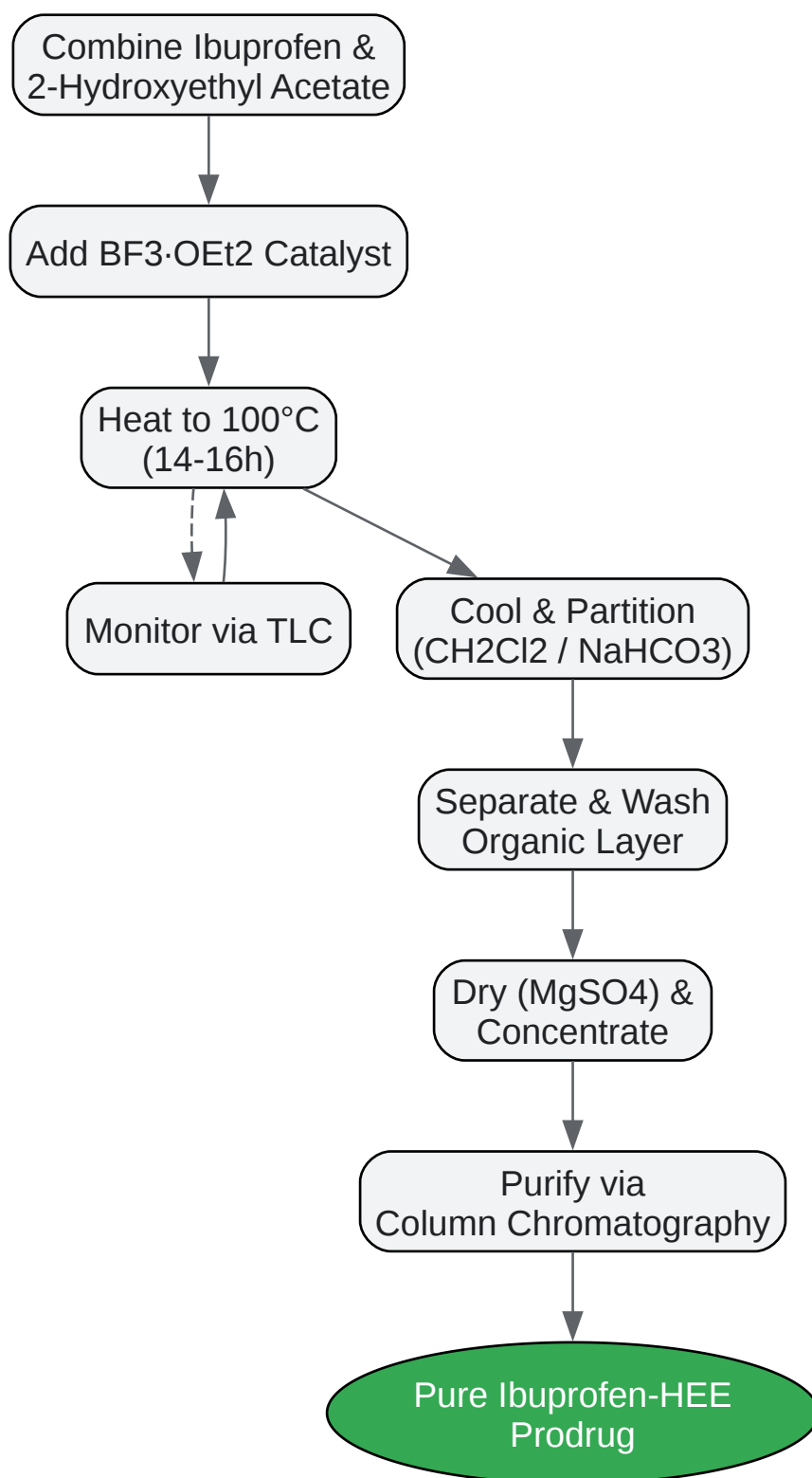

[Click to download full resolution via product page](#)

Caption: Experimental workflow for the synthesis of an Ibuprofen prodrug.

## Protocol 2: Safety, Handling, and Storage

Proper handling of **2-hydroxyethyl acetate** is essential to ensure laboratory safety. It is combustible and can cause serious eye damage. [\[2\]](#)[\[16\]](#)

Parameter	Guideline	References
Personal Protective Equipment (PPE)	<b>Wear tightly fitting safety goggles, chemical-resistant gloves (e.g., nitrile), and a lab coat.</b>	<a href="#">[6]</a> <a href="#">[9]</a> <a href="#">[17]</a>
Handling	Use in a well-ventilated area or fume hood. Avoid contact with skin and eyes. Use non-sparking tools and prevent electrostatic discharge.	<a href="#">[6]</a> <a href="#">[18]</a>
Storage	Store in a tightly closed container in a cool, dry, and well-ventilated place away from incompatible materials like strong oxidizing agents, acids, and bases.	<a href="#">[6]</a> <a href="#">[9]</a> <a href="#">[17]</a> <a href="#">[18]</a>
Spill Response	Absorb spill with inert material (e.g., sand, vermiculite). Collect and place in a suitable, closed container for disposal. Remove all ignition sources.	<a href="#">[6]</a> <a href="#">[9]</a>

| First Aid (Eyes) | Immediately rinse with water for several minutes. Remove contact lenses if present and easy to do. Continue rinsing and seek immediate medical attention. | [\[16\]](#)

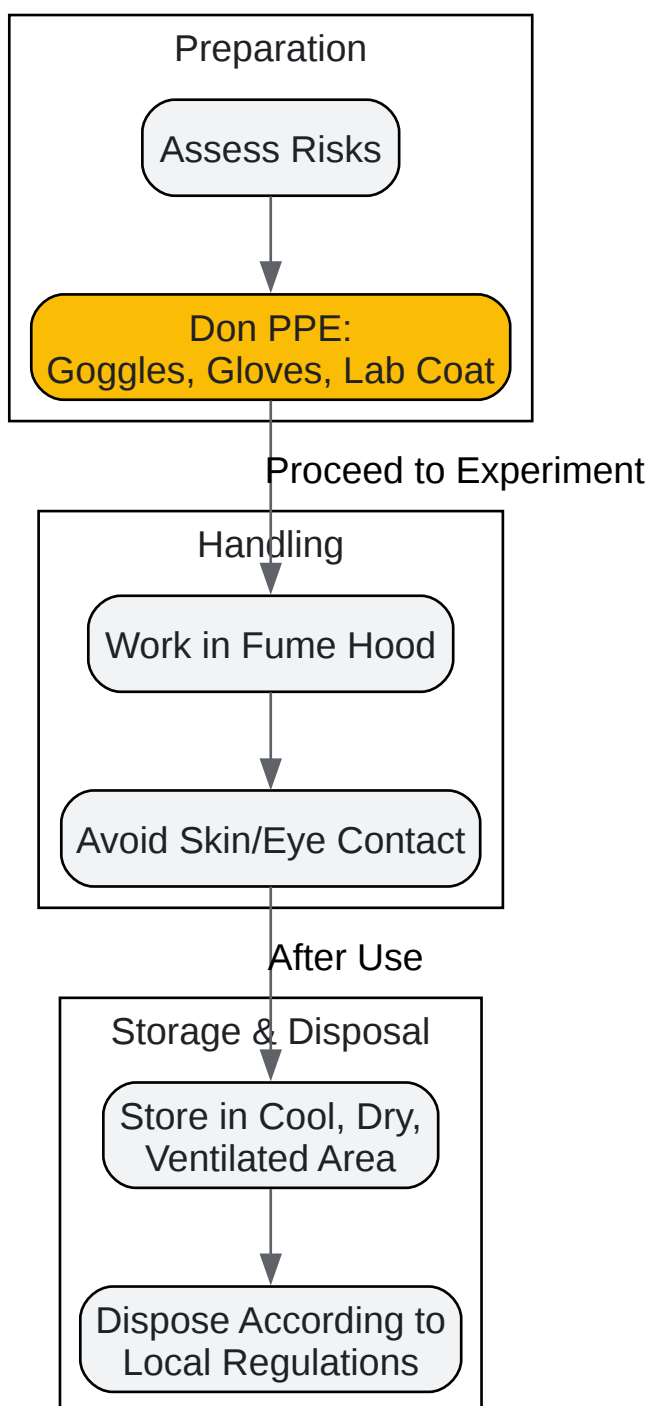

[Click to download full resolution via product page](#)

Caption: Laboratory safety workflow for handling **2-hydroxyethyl acetate**.

## References

- Material Safety Data Sheet - **2-Hydroxyethyl acetate** (prac) - Cole-Parmer. (n.d.). Retrieved from Cole-Parmer. [\[Link\]](#)
- **2-hydroxyethyl acetate** - Stenutz. (n.d.). Retrieved from Stenutz. [\[Link\]](#)
- Glycol monoacetate | C<sub>4</sub>H<sub>8</sub>O<sub>3</sub> | CID 10960 - PubChem. (n.d.). Retrieved from National Institutes of Health. [\[Link\]](#)
- What is the **2-hydroxyethyl acetate** density? - Zibo Anquan Chemical Co., Ltd. (2023). Retrieved from Zibo Anquan Chemical Co., Ltd. [\[Link\]](#)
- Advances on Greener Asymmetric Synthesis of Antiviral Drugs via Organocatalysis - MDPI. (n.d.). Retrieved from MDPI. [\[Link\]](#)
- CAS No : 542-59-6 | Product Name : **2-Hydroxyethyl Acetate** - Pharmaffiliates. (n.d.). Retrieved from Pharmaffiliates. [\[Link\]](#)
- Synthesis and antiviral effect of novel fluoxetine analogues as enterovirus 2C inhibitors. (n.d.). Retrieved from ResearchGate. [\[Link\]](#)
- Chemists synthesize an improved building block for medicines - ScienceDaily. (2024). Retrieved from ScienceDaily. [\[Link\]](#)
- **2-Hydroxyethyl acetate** - ChemBK. (2024). Retrieved from ChemBK. [\[Link\]](#)
- Kinetics of Transesterification of 2-Ethoxyethyl Acetate and 2-Butoxyethanol Catalyzed by Niobium Oxide - Figshare. (2025). Retrieved from Figshare. [\[Link\]](#)
- Synthesis and Hydrolytic Behavior of Ibuprofen Prodrugs and their PEGylated Derivatives. (2008). Retrieved from Taylor & Francis Online. [\[Link\]](#)
- Prodrug approaches for the development of a long-acting drug delivery systems - PMC - NIH. (n.d.). Retrieved from National Institutes of Health. [\[Link\]](#)
- Synthesis and anti-hepatitis C virus activity of 2'(beta)-hydroxyethyl and 4'(alpha)-hydroxymethyl carbodine analogues - PubMed. (2009). Retrieved from National Institutes of Health. [\[Link\]](#)

- Carbon-based solid acids catalyze the synthesis of ethylene glyco... - Ingenta Connect. (2023). Retrieved from Ingenta Connect. [\[Link\]](#)
- Chemists synthesize an improved building block for medicines - chemeurope.com. (2024). Retrieved from chemeurope.com. [\[Link\]](#)
- Synthesis and Antiviral Activity of a Series of 2'-C-Methyl-4'-thionucleoside Monophosphate Prodrugs - NIH. (2020). Retrieved from National Institutes of Health. [\[Link\]](#)
- Synthesis and antiviral activity of sulfated and acetylated derivatives of 2beta,3alpha-dihydroxy-5alpha-cholestane - PubMed. (n.d.). Retrieved from National Institutes of Health. [\[Link\]](#)
- Heterocyclic Building Blocks - Pharmaceutical Technology. (n.d.). Retrieved from Pharmaceutical Technology. [\[Link\]](#)
- 2-Ethoxyethyl acetate - Wikipedia. (n.d.). Retrieved from Wikipedia. [\[Link\]](#)
- Glycerol transesterification with ethyl acetate to synthesize acetins using ethyl acetate as reactant and entrainer - Biofuel Research Journal. (2017). Retrieved from Biofuel Research Journal. [\[Link\]](#)
- CN101337884A - Method for preparing 2-Butoxyethyl acetate by continuous esterification reaction - Google Patents. (n.d.).
- RU2062266C1 - Method for production of 2-ethoxyethyl acetate - Google Patents. (n.d.).
- CN103183609B - Preparation method of ethylene glycol monoacetate and ethylene glycol diacetate - Google Patents. (n.d.).
- Synthesis of bio-additives: transesterification of ethyl acetate with glycerol using homogeneous or heterogeneous acid catalysts - SciELO. (2013). Retrieved from SciELO. [\[Link\]](#)
- Exploration of Esterification Hydroxyethyl Cellulose (HEC) by Modified 2,2',2'',2'''-(Ethane-1,2-Diylbis (Azanetriyl)) Tetraacet. (2025). Retrieved from In Review. [\[Link\]](#)
- CN103183609A - Preparation method of ethylene glycol monoacetate and ethylene glycol diacetate - Google Patents. (n.d.).

- Glycerol transesterification with ethyl acetate to synthesize acetins using ethyl acetate as reactant and entrainer - Biofuel Research Journal. (n.d.). Retrieved from Biofuel Research Journal. [[Link](#)]
- Optimizing Organic Synthesis: The Role of Ethylene Glycol Mono-tert-butyl Ether. (2026). Retrieved from LookChem. [[Link](#)]
- (PDF) Glycerol transesterification with ethyl acetate to synthesize acetins using ethyl acetate as reactant and entrainer - ResearchGate. (2025). Retrieved from ResearchGate. [[Link](#)]

### Need Custom Synthesis?

BenchChem offers custom synthesis for rare earth carbides and specific isotopic labeling.

Email: [info@benchchem.com](mailto:info@benchchem.com) or [Request Quote Online](#).

## Sources

- 1. [benchchem.com](https://benchchem.com) [[benchchem.com](https://benchchem.com)]
- 2. 2-HYDROXYETHYL ACETATE | 542-59-6 [[chemicalbook.com](https://chemicalbook.com)]
- 3. Glycol monoacetate | C4H8O3 | CID 10960 - PubChem [[pubchem.ncbi.nlm.nih.gov](https://pubchem.ncbi.nlm.nih.gov)]
- 4. [pharmaffiliates.com](https://pharmaffiliates.com) [[pharmaffiliates.com](https://pharmaffiliates.com)]
- 5. [scbt.com](https://scbt.com) [[scbt.com](https://scbt.com)]
- 6. [chemicalbook.com](https://chemicalbook.com) [[chemicalbook.com](https://chemicalbook.com)]
- 7. 2-hydroxyethyl acetate [[stenutz.eu](https://stenutz.eu)]
- 8. CAS 542-59-6: Glycol monoacetate | CymitQuimica [[cymitquimica.com](https://cymitquimica.com)]
- 9. [pim-resources.coleparmer.com](https://pim-resources.coleparmer.com) [[pim-resources.coleparmer.com](https://pim-resources.coleparmer.com)]
- 10. [ingentaconnect.com](https://ingentaconnect.com) [[ingentaconnect.com](https://ingentaconnect.com)]
- 11. CN103183609B - Preparation method of ethylene glycol monoacetate and ethylene glycol diacetate - Google Patents [[patents.google.com](https://patents.google.com)]
- 12. CN103183609A - Preparation method of ethylene glycol monoacetate and ethylene glycol diacetate - Google Patents [[patents.google.com](https://patents.google.com)]
- 13. Synthesis and anti-hepatitis C virus activity of 2'(beta)-hydroxyethyl and 4'(alpha)-hydroxymethyl carbodine analogues - PubMed [[pubmed.ncbi.nlm.nih.gov](https://pubmed.ncbi.nlm.nih.gov)]

- [14. Synthesis and Antiviral Activity of a Series of 2'-C-Methyl-4'-thionucleoside Monophosphate Prodrugs - PMC \[pmc.ncbi.nlm.nih.gov\]](#)
- [15. tandfonline.com \[tandfonline.com\]](#)
- [16. chemscene.com \[chemscene.com\]](#)
- [17. tcichemicals.com \[tcichemicals.com\]](#)
- [18. fishersci.com \[fishersci.com\]](#)
- To cite this document: BenchChem. [Application Notes & Protocols: The Role of 2-Hydroxyethyl Acetate in Modern Pharmaceutical Synthesis]. BenchChem, [2026]. [Online PDF]. Available at: [<https://www.benchchem.com/product/b7771454/docs#application-notes-protocols-the-role-of-2-hydroxyethyl-acetate-in-modern-pharmaceutical-synthesis>]

---

#### Disclaimer & Data Validity:

The information provided in this document is for Research Use Only (RUO) and is strictly not intended for diagnostic or therapeutic procedures. While BenchChem strives to provide accurate protocols, we make no warranties, express or implied, regarding the fitness of this product for every specific experimental setup.

**Technical Support:** The protocols provided are for reference purposes. Unsure if this reagent suits your experiment?

**Need Industrial/Bulk Grade?** [Request Custom Synthesis Quote](#)

## BenchChem

Our mission is to be the trusted global source of essential and advanced chemicals, empowering scientists and researchers to drive progress in science and industry.

#### Contact

Address: 3281 E Guasti Rd  
Ontario, CA 91761, United States  
Phone: (601) 213-4426  
Email: [info@benchchem.com](mailto:info@benchchem.com)

Contact our Ph.D. Support Team for a compatibility check