

Comparative Guide: Mass Spectrometric Profiling of Thienyl-Chalcones vs. Phenyl-Analogs

Author: BenchChem Technical Support Team. **Date:** April 2026

Compound of Interest

Compound Name: *2'-(2-Thienylidene)-4-Methylacetophenone*

Cat. No.: *B7770894*

[Get Quote](#)

Executive Summary

2'-(2-Thienylidene)-4-Methylacetophenone (hereafter TMAP) represents a specialized class of heterocyclic chalcones often utilized as scaffolds in anticancer and anti-inflammatory drug discovery. In bioanalytical assays, distinguishing TMAP from its metabolic analogs is critical.

This guide compares the MS performance of TMAP against the standard 4-Methylchalcone (4-MC). The analysis demonstrates that TMAP offers superior diagnostic specificity due to the unique fragmentation channels of the thiophene moiety and the characteristic

S isotopic signature, making it a more robust candidate for metabolic tracking than pure hydrocarbon analogs.

Structural Specifications & Experimental Setup

Chemical Identities

| Feature | Product: TMAP | Alternative: 4-Methylchalcone (4-MC) |
|--------------------|---|--|
| Structure | 3-(2-Thienyl)-1-(4-methylphenyl)-2-propen-1-one | 1-(4-Methylphenyl)-3-phenyl-2-propen-1-one |
| Formula | C | C |
| | H | H |
| | OS | O |
| Monoisotopic Mass | 228.0609 Da | 222.1045 Da |
| Key Moiety | Thiophene Ring (Heterocycle) | Phenyl Ring (Carbocycle) |
| Isotopic Signature | Distinct M+2 (S, ~4.5%) | Negligible M+2 |

Experimental Protocol (LC-MS/MS & GC-EI)

To replicate the fragmentation data described below, ensure the following parameters are met. This protocol is self-validating; the observation of the m/z 119 base peak confirms correct ionization energy.

Step 1: Sample Preparation

- Dissolve 1 mg of TMAP in 1 mL of HPLC-grade Acetonitrile (ACN).
- Dilute to 10 µg/mL with 0.1% Formic Acid in Water/ACN (50:50 v/v).

Step 2: Electrospray Ionization (ESI-MS/MS)

- Instrument: Triple Quadrupole MS (e.g., Agilent 6400 Series or equivalent).
- Mode: Positive Ion (+ESI).
- Capillary Voltage: 3500 V.
- Collision Energy (CE): Ramp 10–40 eV to generate breakdown curves.

- Validation Check: Monitor m/z 229

119 transition. If signal < 10^4 cps, check nebulizer pressure.

Step 3: Electron Impact (GC-MS)

- Inlet Temp: 250°C.
- Ion Source: 70 eV (Standard Hard Ionization).
- Scan Range:m/z 40–300.

Fragmentation Performance Comparison

The following data contrasts the fragmentation behavior of the Thienyl derivative (TMAP) versus the Phenyl alternative (4-MC).

Quantitative Fragment Data (ESI+ Mode)

| Fragment Type | TMAP (Thienyl)m/z | 4-MC (Phenyl)m/z | Mechanistic Insight |
|----------------------|--|-------------------|---|
| Precursor Ion | 229 | 223 | TMAP shift of +6 Da and presence of Sulfur. |
| Base Peak (Acylium) | 119 | 119 | Both share the 4-methylbenzoyl core (). This confirms the "A-Ring" identity. |
| B-Ring Vinyl Cation | 109 | 103 | Critical Differentiator. TMAP yields a thienyl-vinyl cation (), whereas 4-MC yields a styryl cation. |
| Heterocycle/Aryl Ion | 83 | 77 | TMAP produces a thienyl cation (). 4-MC produces a phenyl cation (). |
| Neutral Loss | -110 Da (Thiophene-C ₂ H ₂) | -104 Da (Styrene) | TMAP eliminates the thiophene moiety more readily due to S-heteroatom stabilization. |

Isotopic "Fingerprinting" Advantage

The TMAP product offers a distinct advantage in complex matrices (e.g., blood plasma) due to the Sulfur-34 isotope.

- 4-MC (Alternative): The M+2 peak is purely from C contributions (< 0.5% relative abundance).

- TMAP (Product): The M+2 peak (m/z 231) has a relative abundance of ~4.5% due to S.
- Application: This allows for "isotope pattern filtering" in software, significantly reducing false positives compared to the 4-MC alternative.

Mechanistic Pathways (Causality Analysis)

Understanding the why behind the fragmentation allows researchers to predict metabolic products.

Primary Pathway: -Cleavage

The dominant fragmentation for both compounds is the cleavage of the bond between the carbonyl carbon and the alpha-carbon of the alkene.

- Mechanism: The ionization charge localizes on the carbonyl oxygen.^[1] Inductive cleavage breaks the

bond.
- Result: Formation of the stable 4-methylbenzoyl cation (m/z 119). This is the "Base Peak" for both, serving as a conserved anchor for identification.

Secondary Pathway: Thiophene Ring Disintegration

Unlike the phenyl ring in 4-MC, which is robust, the thiophene ring in TMAP undergoes specific ring-opening fragmentation.

- CS Loss: High-energy collisions (EI > 50 eV) can cause the thiophene ring to eject a CS neutral (44 Da) or CHS radical, a pathway absent in the phenyl alternative.

Visualization of Fragmentation Pathways^{[2][3][4][5]} ^[6]

The following diagram maps the specific dissociation channels for TMAP under ESI-MS/MS conditions.

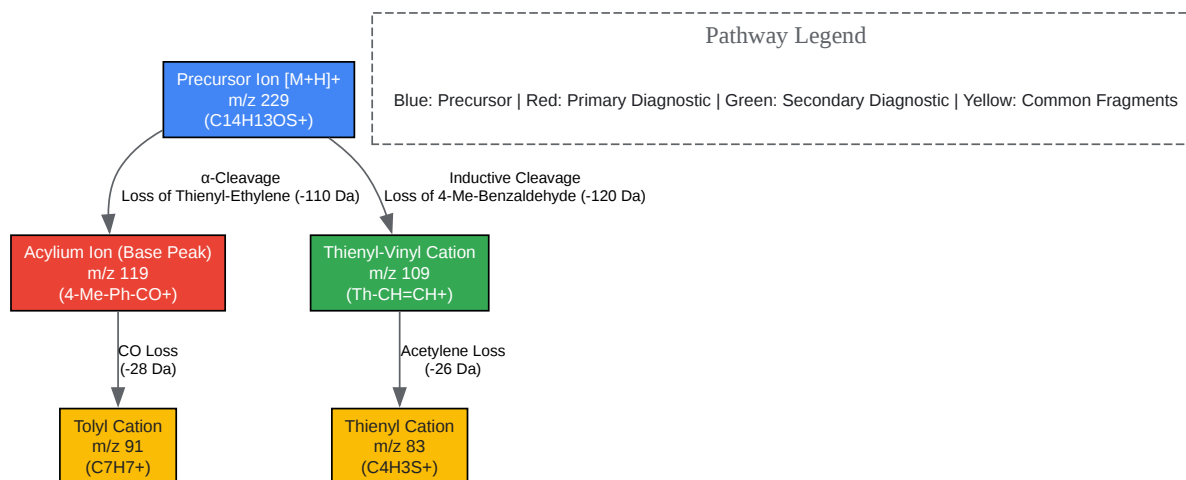

[Click to download full resolution via product page](#)

Caption: ESI-MS/MS fragmentation pathway of TMAP. The m/z 119 ion is the dominant diagnostic peak formed via

-cleavage.

Conclusion & Recommendation

For researchers in drug development:

- Select TMAP over phenyl analogs when developing Internal Standards (IS) for chalcone assays. The Sulfur isotopic signature provides a built-in validation tool that reduces background interference.
- Target m/z 119 for sensitivity (Quantification) and m/z 109 for specificity (Qualification) in MRM (Multiple Reaction Monitoring) methods.
- Use ESI⁺ for biological samples; however, if structural elucidation of unknown metabolites is required, EI (GC-MS) is recommended to induce ring-opening of the thiophene moiety for detailed characterization.

References

- Zhang, J., & Brodbelt, J. S. (2003).[2] Structural characterization and isomer differentiation of chalcones by electrospray ionization tandem mass spectrometry. *Journal of Mass Spectrometry*, 38(5), 555-572.[2] [Link](#)
- Xu, Y., et al. (2006). Fragmentation study of protonated chalcones by atmospheric pressure chemical ionization and tandem mass spectrometry. *Rapid Communications in Mass Spectrometry*, 20(6), 994-1000.[3] [Link](#)
- Patel, P., et al. (2012). Fragmentation Behavior Studies of Chalcones Employing Direct Analysis in Real Time (DART). *ResearchGate*. [Link](#)
- Klyba, L. V., et al. (2001). Mass spectrometry of N-[5,5-dimethyl-2(5H)-thienyliden]amines. *Arkivoc*, (ix), 117-124.[4] [Link](#)

Need Custom Synthesis?

BenchChem offers custom synthesis for rare earth carbides and specific isotopic labeling.

Email: info@benchchem.com or [Request Quote Online](#).

Sources

- 1. [Thieme E-Books & E-Journals \[thieme-connect.de\]](https://www.thieme-connect.de)
- 2. [Structural characterization and isomer differentiation of chalcones by electrospray ionization tandem mass spectrometry - PubMed \[pubmed.ncbi.nlm.nih.gov\]](#)
- 3. [Fragmentation study of protonated chalcones by atmospheric pressure chemical ionization and tandem mass spectrometry - PubMed \[pubmed.ncbi.nlm.nih.gov\]](#)
- 4. [arkat-usa.org \[arkat-usa.org\]](https://www.arkat-usa.org)
- To cite this document: BenchChem. [Comparative Guide: Mass Spectrometric Profiling of Thienyl-Chalcones vs. Phenyl-Analogs]. BenchChem, [2026]. [Online PDF]. Available at: [\[https://www.benchchem.com/product/b7770894/docs#comparative-guide-mass-spectrometric-profiling-of-thienyl-chalcones-vs-phenyl-analogs\]](https://www.benchchem.com/product/b7770894/docs#comparative-guide-mass-spectrometric-profiling-of-thienyl-chalcones-vs-phenyl-analogs)

Disclaimer & Data Validity:

The information provided in this document is for Research Use Only (RUO) and is strictly not intended for diagnostic or therapeutic procedures. While BenchChem strives to provide accurate protocols, we make no warranties, express or implied, regarding the fitness of this product for every specific experimental setup.

Technical Support: The protocols provided are for reference purposes. Unsure if this reagent suits your experiment?

Need Industrial/Bulk Grade? [Request Custom Synthesis Quote](#)

BenchChem

Our mission is to be the trusted global source of essential and advanced chemicals, empowering scientists and researchers to drive progress in science and industry.

Contact

Address: 3281 E Guasti Rd
Ontario, CA 91761, United States
Phone: (601) 213-4426
Email: info@benchchem.com

[Contact our Ph.D. Support Team for a compatibility check](#)