

A Comparative Guide to Gravimetric and Spectrophotometric Analysis Using α -Benzoin Oxime

Author: BenchChem Technical Support Team. **Date:** April 2026

Compound of Interest

Compound Name: *alpha-Benzoin oxime*

CAS No.: 5928-63-2

Cat. No.: B7769832

[Get Quote](#)

For researchers, scientists, and drug development professionals, the accurate quantification of metal ions is a critical aspect of experimental work. **Alpha-Benzoin oxime** has long been utilized as a versatile reagent in two primary analytical techniques: gravimetric analysis and spectrophotometry. This guide provides an objective comparison of these two methods, supported by experimental data and detailed protocols, to aid in the selection of the most suitable technique for your analytical needs.

Performance Characteristics: A Side-by-Side Comparison

The choice between gravimetric and spectrophotometric methods often depends on the required sensitivity, concentration range, and the nature of the sample matrix. Below is a summary of the key performance characteristics of each method based on available data for the determination of copper and molybdenum.

Performance Metric	Gravimetric Method	Spectrophotometric Method
Analyte	Copper (Cu), Molybdenum (Mo)	Copper (Cu), Molybdenum (Mo), Nickel (Ni)
Principle	Precipitation of a metal- α -benzoin oxime complex, followed by drying and weighing.	Formation of a colored metal- α -benzoin oxime complex, followed by measurement of light absorbance.
Linearity Range	Not typically defined; applicable to macro-level concentrations.	0.1 - 18.6 $\mu\text{g/mL}$ for Copper[1]
Detection Limit	Higher, suitable for determining significant quantities.	2 ng/mL for Copper[1]
Molar Absorptivity	Not applicable.	5754 $\text{L mol}^{-1} \text{cm}^{-1}$ for Copper complex[1]
Precision	High precision, with relative standard deviations typically below 0.5%. For molybdenum in alloys, a standard deviation of 0.3% relative has been reported.[2]	Good precision, with a coefficient of variation of 3% reported for molybdenum determination.[3]
Selectivity	Susceptible to interferences from other metal ions that can co-precipitate. For molybdenum, tungsten, palladium, chromium(VI), and vanadium(V) are known interferents.[4]	Can be highly selective depending on the chosen wavelength and pH. However, interferences from tungstate and vanadate have been noted for molybdenum analysis.[3]
Speed	Time-consuming due to precipitation, digestion, filtration, drying, and weighing steps.	Relatively rapid, especially with modern spectrophotometers.

Instrumentation	Requires standard laboratory glassware, a filtration apparatus, a drying oven, and an analytical balance.	Requires a UV-Vis spectrophotometer.
-----------------	---	--------------------------------------

Experimental Protocols

Detailed methodologies are crucial for reproducible and accurate results. The following sections outline the experimental protocols for the gravimetric and spectrophotometric determination of metal ions using α -benzoin oxime.

Gravimetric Determination of Molybdenum

This procedure is adapted from a method for the determination of molybdenum in various materials.[\[4\]](#)

Reagents:

- α -Benzoin oxime solution (2% w/v in ethanol)
- Sulfuric acid (5% v/v)
- Ammonium hydroxide
- Wash solution: Dilute sulfuric acid containing a small amount of α -benzoin oxime.

Procedure:

- Sample Preparation: Dissolve a precisely weighed sample containing molybdenum in a suitable acid. Adjust the acidity of the solution to be approximately 5% in sulfuric acid.[\[4\]](#)
- Precipitation: Cool the solution to 5-10°C and slowly add an excess of the chilled α -benzoin oxime solution with constant stirring.
- Digestion: Allow the precipitate to stand for 10-15 minutes at 5-10°C to ensure complete precipitation.

- Filtration: Filter the precipitate through a pre-weighed Gooch crucible or a filter paper of fine porosity.
- Washing: Wash the precipitate with the cold wash solution to remove any soluble impurities.
- Drying and Weighing: Dry the precipitate to a constant weight in an oven at 105-110°C. Cool in a desiccator and weigh as $\text{Mo}(\text{C}_{14}\text{H}_{12}\text{O}_2\text{N})_3$. The amount of molybdenum can be calculated using the appropriate gravimetric factor.

Spectrophotometric Determination of Copper

This method utilizes a micellar medium to enhance the solubility of the copper- α -benzoin oxime complex.^[1]

Reagents:

- Standard copper solution (100 $\mu\text{g}/\text{mL}$)
- α -Benzoin oxime solution (0.001 M)
- Triton X-100 solution (0.042 M)
- Acetate buffer (pH 4.5)

Procedure:

- Calibration Curve Preparation: To a series of 10 mL volumetric flasks, add varying aliquots of the standard copper solution to achieve concentrations in the range of 0.1-18.6 $\mu\text{g}/\text{mL}$.
- Complex Formation: To each flask, add 1 mL of the 0.001 M α -benzoin oxime solution and 1.6 mL of the 0.042 M Triton X-100 solution.^[1]
- Dilution: Dilute to the mark with the acetate buffer (pH 4.5).
- Measurement: Measure the absorbance of the solutions at the wavelength of maximum absorbance against a reagent blank.

- **Sample Analysis:** Prepare the unknown sample in the same manner and determine its copper concentration from the calibration curve.

Visualizing the Methodologies

To further clarify the experimental processes and the underlying chemical principles, the following diagrams have been generated.

Experimental Workflow

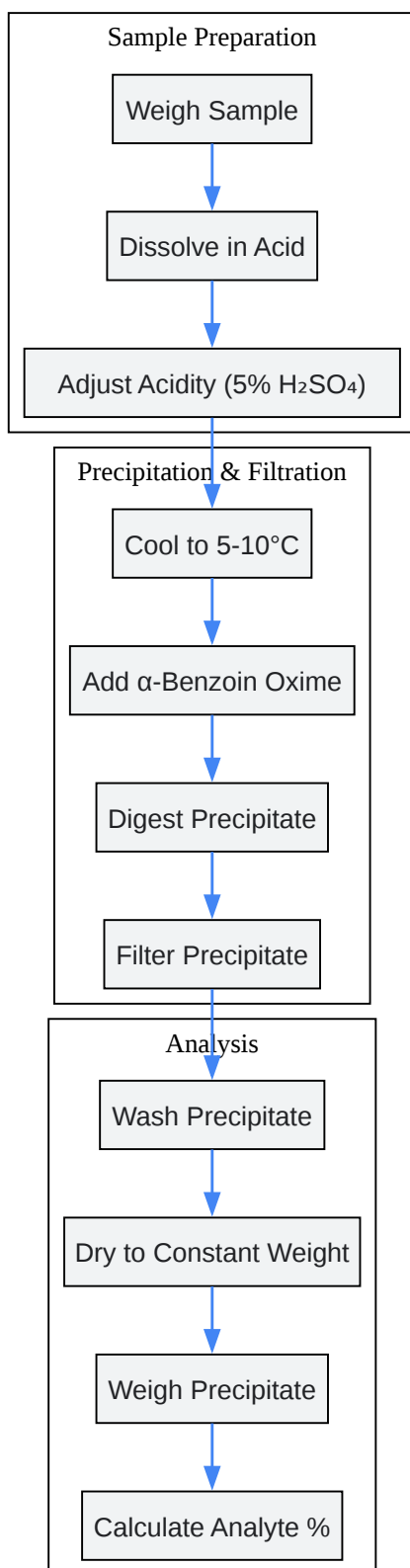

[Click to download full resolution via product page](#)

Caption: Gravimetric analysis workflow.

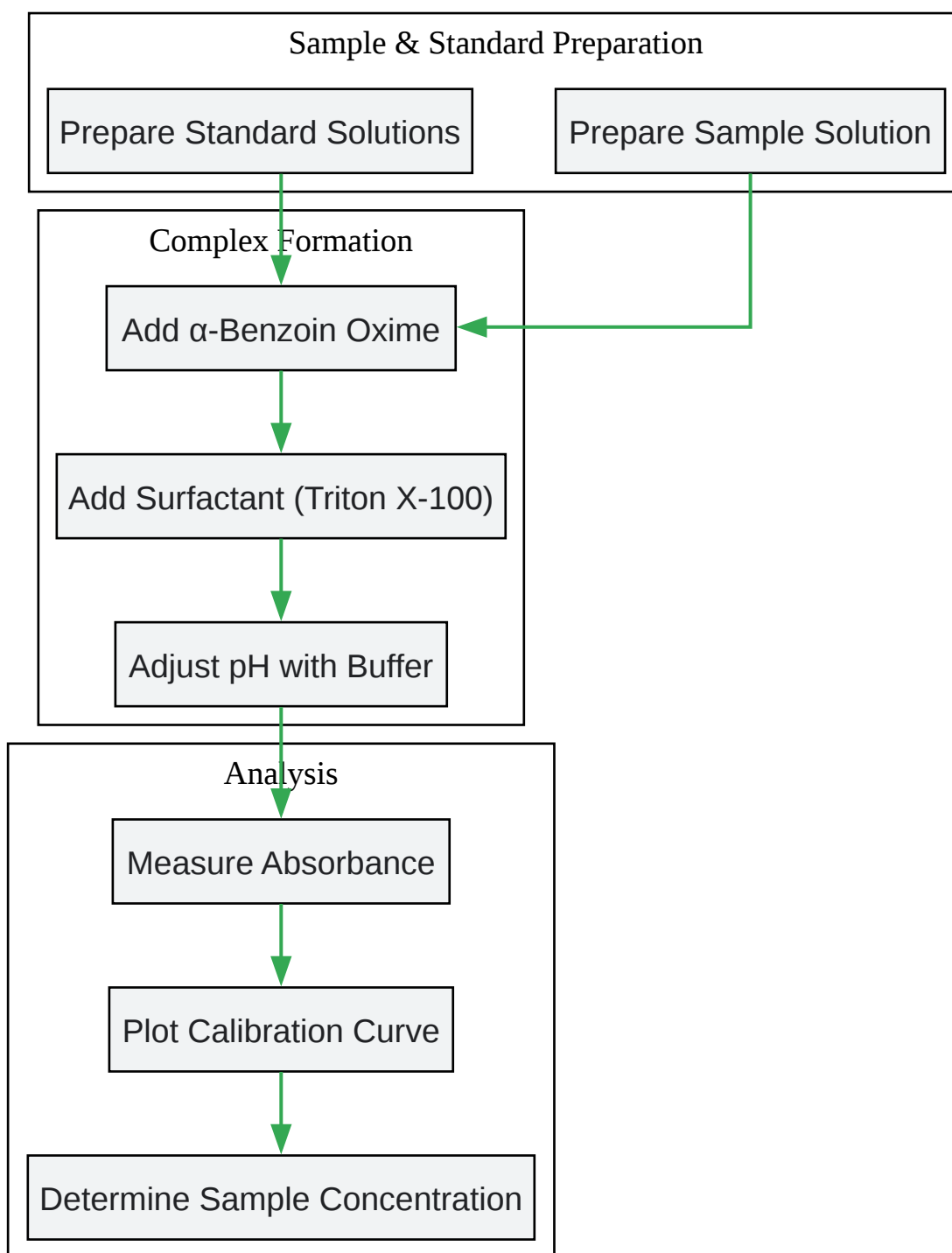

[Click to download full resolution via product page](#)

Caption: Spectrophotometric analysis workflow.

Chemical Reactions

The reaction of α -benzoin oxime with metal ions is the cornerstone of both analytical methods. The following diagrams illustrate the complex formation with copper and molybdenum.

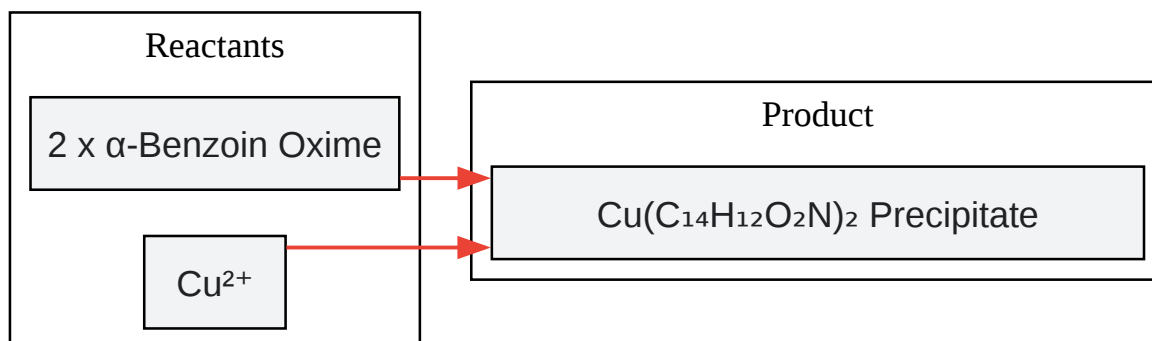

[Click to download full resolution via product page](#)

Caption: Copper- α -Benzoin Oxime complex formation.

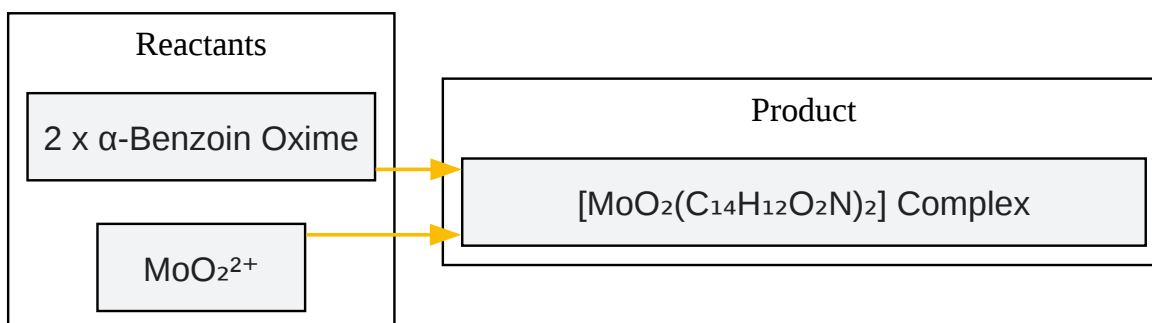

[Click to download full resolution via product page](#)

Caption: Molybdenum- α -Benzoin Oxime complex formation.

Conclusion

Both gravimetric and spectrophotometric methods utilizing α -benzoin oxime offer robust options for the determination of metal ions. The gravimetric method is a classic, highly precise technique best suited for macro-level analysis where high accuracy is paramount. In contrast, the spectrophotometric method provides greater sensitivity and speed, making it ideal for trace analysis and high-throughput screening. The choice of method will ultimately be guided by the

specific requirements of the research, including the expected concentration of the analyte, the complexity of the sample matrix, and the available instrumentation.

Need Custom Synthesis?

BenchChem offers custom synthesis for rare earth carbides and specific isotopic labeling.

Email: info@benchchem.com or [Request Quote Online](#).

References

- [1. asianpubs.org \[asianpubs.org\]](http://asianpubs.org)
- [2. THE GRAVIMETRIC DETERMINATION OF MOLYBDENUM IN URANIUM-MOLYBDENUM ALLOYS WITH /cap alpha/-BENZOINOXIME \(Technical Report\) | OSTI.GOV \[osti.gov\]](#)
- [3. pubs.acs.org \[pubs.acs.org\]](http://pubs.acs.org)
- [4. nvlpubs.nist.gov \[nvlpubs.nist.gov\]](http://nvlpubs.nist.gov)
- To cite this document: BenchChem. [A Comparative Guide to Gravimetric and Spectrophotometric Analysis Using α -Benzoin Oxime]. BenchChem, [2026]. [Online PDF]. Available at: [<https://www.benchchem.com/product/b7769832/docs#a-comparative-guide-to-gravimetric-and-spectrophotometric-analysis-using-benzoin-oxime>]

Disclaimer & Data Validity:

The information provided in this document is for Research Use Only (RUO) and is strictly not intended for diagnostic or therapeutic procedures. While BenchChem strives to provide accurate protocols, we make no warranties, express or implied, regarding the fitness of this product for every specific experimental setup.

Technical Support: The protocols provided are for reference purposes. Unsure if this reagent suits your experiment?

Need Industrial/Bulk Grade? [Request Custom Synthesis Quote](#)

BenchChem

Our mission is to be the trusted global source of essential and advanced chemicals, empowering scientists and researchers to drive progress in science and industry.

Contact

Address: 3281 E Guasti Rd

Ontario, CA 91761, United States

Phone: (601) 213-4426

Email: info@benchchem.com

[Contact our Ph.D. Support Team for a compatibility check](#)