

Introduction: Beyond Conventional Enolates

Author: BenchChem Technical Support Team. **Date:** April 2026

Compound of Interest

Compound Name: *Tin(2+); trifluoromethanesulfonate*

Cat. No.: *B7768709*

[Get Quote](#)

In the landscape of synthetic organic chemistry, the formation of carbon-carbon bonds via metal enolates stands as a cornerstone methodology. For decades, chemists have relied heavily on alkali metal enolates, particularly those of lithium, which are typically generated under strongly basic conditions. While effective, these methods often lack functional group tolerance and require cryogenic temperatures. The advent of silyl enol ethers, utilized in the Mukaiyama aldol reaction, offered a milder alternative, but requires a stoichiometric Lewis acid for activation^{[1][2][3]}.

Tin(II) enolates have emerged as a distinct and powerful class of intermediates that bridge this gap. A key advantage lies in their generation under exceptionally mild and neutral conditions, a stark contrast to the harsh requirements for lithium enolate formation^[4]. This unique characteristic, coupled with their remarkable stereocontrol in reactions, has established tin(II) enolates as indispensable tools for the precise construction of complex molecular architectures, particularly in the fields of natural product synthesis and drug development. This guide provides a comprehensive exploration of the fundamental chemistry of tin(II) enolates, from their generation and structural nuances to their profound applications in stereoselective synthesis.

Generation of Tin(II) Enolates: Mild and Versatile Pathways

The utility of tin(II) enolates stems directly from the convenient and gentle methods available for their preparation. Unlike their tin(IV) counterparts, tin(II) enolates were relatively unexplored until efficient generation methods were developed[4].

Direct Enolization of Carbonyls with Tin(II) Triflate

The most widely employed method involves the direct enolization of a ketone or thioester using tin(II) trifluoromethanesulfonate ($\text{Sn}(\text{OTf})_2$), a potent Lewis acid, in the presence of a tertiary amine[4][5]. This approach is prized for its operational simplicity and mild, neutral reaction conditions.

The amine, typically triethylamine (Et_3N) or N-ethylpiperidine, acts as a base to abstract an α -proton from the carbonyl compound. The highly Lewis acidic tin(II) center coordinates to the carbonyl oxygen, facilitating this deprotonation and forming the tin(II) enolate.

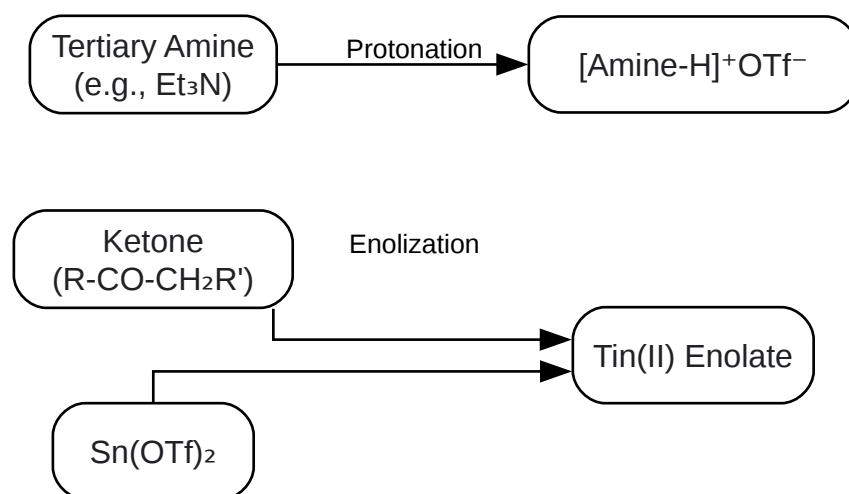

[Click to download full resolution via product page](#)

Caption: Workflow for Tin(II) Enolate generation via direct enolization.

Experimental Protocol: Generation of a Tin(II) Enolate from a Ketone

- Preparation: Under an inert atmosphere (Argon or Nitrogen), add a solution of the ketone (1.0 equiv) in a dry, aprotic solvent (e.g., Dichloromethane, THF) to a stirred suspension of Tin(II) Triflate (1.1 equiv).

- Cooling: Cool the mixture to the desired temperature, typically $-78\text{ }^{\circ}\text{C}$, to control the reaction rate and selectivity.
- Base Addition: Slowly add a solution of a tertiary amine (e.g., N-ethylpiperidine, 1.15 equiv) in the same dry solvent.
- Enolization: Stir the mixture at this temperature for a specified time (e.g., 30-60 minutes) to ensure complete formation of the tin(II) enolate.
- Reaction: The resulting tin(II) enolate solution is now ready for direct use in subsequent reactions (e.g., addition of an aldehyde for an aldol reaction).

Oxidative Addition to α -Halocarbonyl Compounds

An alternative, historically significant method is the in situ generation of tin(II) enolates via the oxidative addition of metallic tin to α -halocarbonyl compounds, such as α -bromoketones[6]. This reaction leverages the reducing power of metallic tin to form the enolate directly, which can then be trapped by an electrophile present in the reaction mixture[4][7].

This method is particularly valuable as it forms the enolate regioselectively at the site of the halogen[6]. The reducing capability of metallic tin is superior to that of tin(II) salts like SnF_2 , allowing for the reduction of a broader range of α -haloesters and ketones[4].

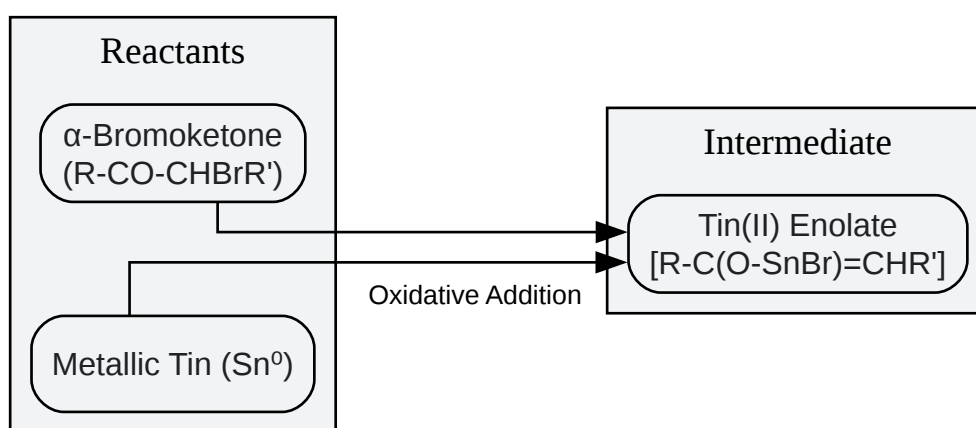

[Click to download full resolution via product page](#)

Caption: Workflow for Tin(II) Enolate generation via oxidative addition.

Specialized Methods: Addition to Ketenes

For specific substrates like thioesters, a clever method involves the addition of stannous thiolates to ketenes[8]. This reaction proceeds efficiently to generate the corresponding tin(II) thioester enolate, which can then be used in subsequent carbon-carbon bond-forming reactions[8].

Structure, Bonding, and the Role of Ligands

The reactivity and stereoselectivity of tin(II) enolates are intrinsically linked to their structure. The tin(II) center possesses a stereochemically active lone pair of electrons, which, along with the ligands, dictates the geometry around the metal. In many tin(II) compounds, the atoms closest to the tin center form a trigonal pyramidal geometry with the tin atom at the apex[9].

A pivotal feature of tin(II) enolate chemistry is the ability to introduce chiral ligands, most notably chiral diamines derived from amino acids like (S)-proline[4]. These diamines chelate to the tin(II) center, creating a rigid, chiral environment. This coordination is fundamental to achieving high levels of enantioselectivity in reactions, as it controls the facial trajectory of the incoming electrophile[4][10].

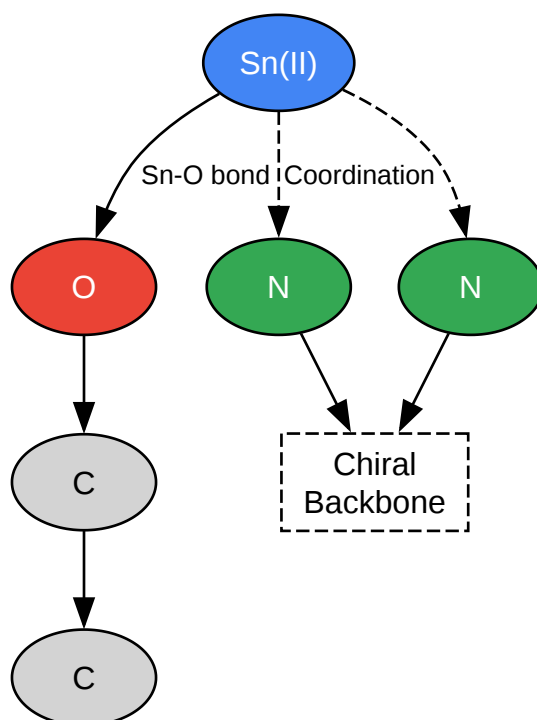

[Click to download full resolution via product page](#)

Caption: Chelation of a chiral diamine to a Tin(II) enolate center.

Reactivity and Synthetic Applications

Tin(II) enolates are versatile nucleophiles, participating in a range of crucial carbon-carbon bond-forming reactions. Their predictable and often high stereoselectivity is their most valuable attribute.

The Aldol Reaction: A Paradigm of Stereocontrol

The aldol reaction is the most prominent application of tin(II) enolates. They react smoothly with aldehydes and ketones to furnish β -hydroxy carbonyl compounds, often with exceptional levels of stereocontrol.

Stereoselectivity and the Zimmerman-Traxler Model: The diastereoselectivity of the tin(II) enolate aldol reaction is rationalized by the Zimmerman-Traxler transition state model[11]. Tin(II) enolates typically exist as the (Z)-enolate isomer. This geometry, when reacting through a closed, six-membered chair-like transition state, preferentially leads to the syn-aldol adduct[11]. This is a consequence of the steric interactions in the transition state, where the substituent on the aldehyde (R^2) and the substituent on the enolate (R^1) both prefer to occupy pseudo-equatorial positions to minimize steric strain.

Caption: The Zimmerman-Traxler model for syn-diastereoselectivity.

Asymmetric Aldol Reactions: The true power of tin(II) enolates is unleashed in asymmetric aldol reactions. By employing a chiral diamine ligand, it is possible to carry out highly enantioselective aldol reactions between two achiral starting materials (an achiral ketone and an achiral aldehyde)[4]. This circumvents the need for chiral auxiliaries, which require additional steps for attachment and removal, thereby improving overall efficiency[4]. The chiral diamine-tin complex forms a rigid structure that effectively shields one face of the enolate, directing the aldehyde to attack from the less hindered face.

Table 1: Asymmetric Aldol Reactions using Chiral Diamine-Sn(OTf)₂ System

Ketone Enolate Source	Aldehyde	Chiral Diamine Ligand	Diastereomeric Ratio (syn:anti)	Enantiomeric Excess (% ee) of syn-isomer
3-pentanone	Benzaldehyde	(S)-1-methyl-2-(piperidinomethyl)pyrrolidine	95:5	90
Propiophenone	Isovaleraldehyde	(S)-1-methyl-2-(1-pyrrolidinylmethyl)pyrrolidine	>98:2	95
S-Ethyl propanethioate	Benzaldehyde	(S)-1-isopropyl-2-(piperidinomethyl)pyrrolidine	92:8	96

Data synthesized from representative literature.

The Michael Addition: Expanding the Scope

Tin(II) enolates also participate in Michael (conjugate) additions to α,β -unsaturated carbonyl compounds, forming 1,5-dicarbonyl products[12]. While thermodynamically less favored than the aldol addition in some cases, the reaction can be effectively promoted[13]. The use of additives like chlorotrimethylsilane (TMSCl) has been shown to activate the α,β -unsaturated ketone, facilitating the smooth addition of the tin(II) enolate[14]. In some protocols, byproducts generated during the enolate formation, such as lithium halides, can themselves act as promoters for the subsequent Michael addition, enabling efficient one-pot procedures[13].

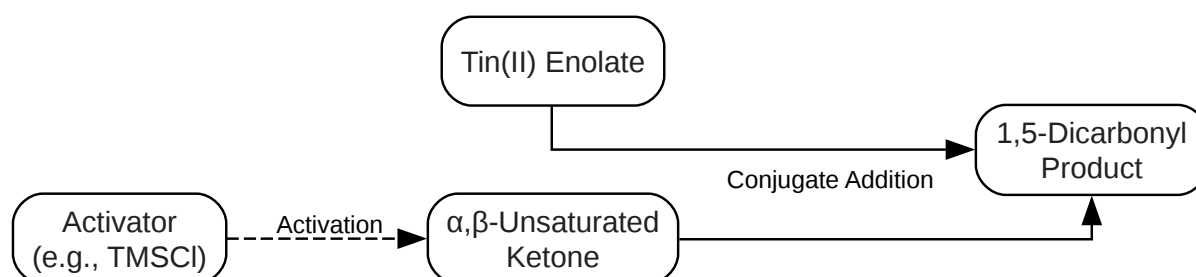

[Click to download full resolution via product page](#)

Caption: General workflow for the Tin(II) enolate Michael addition.

Comparative Overview of Common Enolates

To contextualize the utility of tin(II) enolates, a comparison with other prevalent metal enolates is instructive.

Table 2: Comparison of Metal Enolates in Organic Synthesis

Feature	Lithium Enolates	Boron Enolates	Silyl Enol Ethers (Mukaiyama)	Tin(II) Enolates
Generation	Strong bases (e.g., LDA), cryogenic temps (-78 °C)	Boron triflates/halides + amine base	Carbonyl + Silylating agent (e.g., TMSCl)	Sn(OTf) ₂ + amine base; or Metallic Sn + α-haloketone
Conditions	Strongly basic, anhydrous	Mildly basic/neutral	Neutral, requires Lewis acid catalyst	Mild, neutral[4]
Stereocontrol	High (Zimmerman-Traxler), dependent on enolate geometry	Very high (Zimmerman-Traxler), predictable geometry	Variable, often depends on Lewis acid and open vs. closed transition states[2]	High syn-selectivity from (Z)-enolates (Zimmerman-Traxler)[11]
Asymmetry	Primarily substrate or auxiliary control	Chiral auxiliaries or chiral boron reagents	Chiral Lewis acid catalysis[1]	Chiral ligand control on the metal center[4]
Key Advantage	High reactivity, well-established	Excellent stereoselectivity	Stable, isolable nucleophiles	Mild generation, high stereocontrol with chiral ligands
Limitation	Poor functional group tolerance, strongly basic	Stoichiometric use of boron reagents often needed	Requires stoichiometric Lewis acid, sometimes poor diastereoselectivity	Stoichiometric use of tin reagent

Conclusion

Tin(II) enolates occupy a valuable niche in the synthetic chemist's toolkit. Their defining feature—generation under mild, neutral conditions—liberates them from the constraints of the strongly basic environments required for traditional alkali metal enolates. This mildness, combined with a highly organized transition state, provides a reliable platform for achieving exceptional levels of diastereoselectivity in aldol-type reactions. Furthermore, the ability to coordinate chiral diamines directly to the tin(II) center has paved the way for some of the most efficient and practical methods for catalytic asymmetric C-C bond formation. For researchers and professionals in drug development, where the precise control of stereochemistry is paramount, the fundamental chemistry of tin(II) enolates offers a powerful and elegant solution to complex synthetic challenges.

References

- Mukaiyama, T., & Kobayashi, S. (1994). Tin(II) Enolates in the Aldol, Michael, and Related Reactions. *Organic Reactions*, 46, 1. [\[Link\]](#)
- Harada, T., & Mukaiyama, T. (1982). A New Method for the Regio- and Stereoselective Synthesis of Aldols from α -Bromoketone and Carbonyl Compounds by Using Metallic Tin. *Chemistry Letters*, 11(4), 467-470. [\[Link\]](#)
- Duthaler, R. O., & Hafner, A. (1992). Chiral enolates. A review of the literature. *Chemical Reviews*, 92(4), 807-832. (This link is provided through ResearchGate which links to the original article). [\[Link\]](#)
- Mukaiyama, T., et al. (1983). A Convenient Method for the Generation of Tin(II) Thioester Enolate and Its Reaction with Aldehyde. *Chemistry Letters*, 12(7), 1041-1044. [\[Link\]](#)
- Yura, T., Iwasawa, N., & Mukaiyama, T. (1988). New Possibilities in the Michael Reaction by the Use of Tin(II) Enolates. *Chemistry Letters*, 17(6), 1021-1022. [\[Link\]](#)
- Crimmins, M. T., & She, J. (2003). Anti-Selective Aldol Reactions with Titanium Enolates of N-Glycolyloxazolidinethiones. *Organic Letters*, 5(4), 499-501. [\[Link\]](#)
- Pereyre, M., Quintard, J. P., & Rahm, A. (1987). *Tin in Organic Synthesis*. Butterworth-Heinemann. [\[Link\]](#)

- NotVoodoo. (2015). Why do Zr, Sn, and Ti enolates form syn aldols selectively? Chemistry Stack Exchange. [[Link](#)]
- Kobayashi, S., & Sugiura, M. (2006). Asymmetric Mukaiyama Aldol Reaction. In Comprehensive Organic Name Reactions and Reagents. John Wiley & Sons, Inc. [[Link](#)]
- Sharma, A., et al. (2023). Mukaiyama aldol reaction: an effective asymmetric approach to access chiral natural products and their derivatives/analogues. RSC Advances, 13(48), 33815-33845. [[Link](#)]
- Harada, T., & Mukaiyama, T. (1981). Aldehyde Enolate. Cross Aldol Reaction via Tin(II) Enolate. Chemistry Letters, 10(12), 1701-1702. [[Link](#)]
- Mukaiyama, T. (2004). The Mukaiyama Aldol Reaction: From Discovery to the Latest Advances. Angewandte Chemie International Edition, 43(41), 5488-5527. [[Link](#)]
- MySkinRecipes. (n.d.). Tin(II) trifluoromethanesulfonate. [[Link](#)]
- Ashenhurst, J. (2023). The Michael Addition Reaction and Conjugate Addition. Master Organic Chemistry. [[Link](#)]
- Jordan, T. H., et al. (1976). Crystallographic studies of tin(II) compounds. 2. Structures of tin(II) hydrogen phosphate and tin(II) phosphite, SnHPO₄ and SnHPO₃. Inorganic Chemistry, 15(8), 1960-1964. [[Link](#)]

Need Custom Synthesis?

BenchChem offers custom synthesis for rare earth carbides and specific isotopic labeling.

Email: info@benchchem.com or [Request Quote Online](#).

Sources

1. Thieme E-Books & E-Journals [thieme-connect.de]
2. Mukaiyama aldol reaction: an effective asymmetric approach to access chiral natural products and their derivatives/analogues - RSC Advances (RSC Publishing) DOI:10.1039/D3RA05058K [pubs.rsc.org]

- [3. Mukaiyama aldol addition - Wikipedia \[en.wikipedia.org\]](#)
- [4. organicreactions.org \[organicreactions.org\]](#)
- [5. Tin\(II\) trifluoromethanesulfonate \[myskinrecipes.com\]](#)
- [6. academic.oup.com \[academic.oup.com\]](#)
- [7. academic.oup.com \[academic.oup.com\]](#)
- [8. academic.oup.com \[academic.oup.com\]](#)
- [9. researchgate.net \[researchgate.net\]](#)
- [10. researchgate.net \[researchgate.net\]](#)
- [11. chemistry.stackexchange.com \[chemistry.stackexchange.com\]](#)
- [12. masterorganicchemistry.com \[masterorganicchemistry.com\]](#)
- [13. Thieme E-Journals - Synthesis / Abstract \[thieme-connect.com\]](#)
- [14. academic.oup.com \[academic.oup.com\]](#)
- To cite this document: BenchChem. [Introduction: Beyond Conventional Enolates]. BenchChem, [2026]. [Online PDF]. Available at: [\[https://www.benchchem.com/product/b7768709/docs#introduction-beyond-conventional-enolates\]](https://www.benchchem.com/product/b7768709/docs#introduction-beyond-conventional-enolates)

Disclaimer & Data Validity:

The information provided in this document is for Research Use Only (RUO) and is strictly not intended for diagnostic or therapeutic procedures. While BenchChem strives to provide accurate protocols, we make no warranties, express or implied, regarding the fitness of this product for every specific experimental setup.

Technical Support: The protocols provided are for reference purposes. Unsure if this reagent suits your experiment?

Need Industrial/Bulk Grade? [Request Custom Synthesis Quote](#)

BenchChem

Our mission is to be the trusted global source of essential and advanced chemicals, empowering scientists and researchers to drive progress in science and industry.

Contact

Address: 3281 E Guasti Rd

Ontario, CA 91761, United States

Phone: (601) 213-4426

Email: info@benchchem.com

[Contact our Ph.D. Support Team for a compatibility check](#)