

Application Notes: Flow Cytometry Analysis of Cell Cycle Arrest by EGCG

Author: BenchChem Technical Support Team. **Date:** May 2026

Compound of Interest

Compound Name: (-)-Epigallocatechin gallate

CAS No.: 2041570-28-7

Cat. No.: B7765708

[Get Quote](#)

Introduction

Epigallocatechin-3-gallate (EGCG), the most abundant catechin in green tea, has garnered significant attention for its potential as a chemopreventive and therapeutic agent in cancer research.[1] A primary mechanism of EGCG's anticancer activity is its ability to induce cell cycle arrest, thereby inhibiting the proliferation of cancer cells. Flow cytometry is a powerful and widely used technique to analyze the distribution of cells in different phases of the cell cycle (G0/G1, S, and G2/M) based on their DNA content. This application note provides a comprehensive overview of the use of flow cytometry to study EGCG-induced cell cycle arrest, including detailed protocols and an analysis of the underlying molecular pathways.

Mechanism of EGCG-Induced Cell Cycle Arrest

EGCG has been shown to induce cell cycle arrest at both the G1 and G2/M phases in various cancer cell lines.[2][3][4] The specific phase of arrest is often dependent on the cell type and the concentration of EGCG used.

G1 Phase Arrest:

In many cancer cell types, EGCG treatment leads to an accumulation of cells in the G1 phase of the cell cycle.[5] This is primarily achieved through the modulation of key regulatory proteins:

- Upregulation of Cyclin-Dependent Kinase Inhibitors (CKIs): EGCG increases the expression of p21/WAF1 and p27/KIP1.[6] These proteins bind to and inhibit the activity of cyclin-CDK complexes that are essential for the G1 to S phase transition.
- Downregulation of Cyclins and Cyclin-Dependent Kinases (CDKs): EGCG treatment has been shown to decrease the expression of Cyclin D1, CDK4, and CDK6, which are critical for progression through the G1 phase.[6]

G2/M Phase Arrest:

In some cancer cell lines, EGCG induces arrest at the G2/M checkpoint.[2][4] This is often associated with:

- Modulation of G2/M regulatory proteins: EGCG can influence the expression and activity of proteins such as Cyclin B1 and CDK1, which are crucial for entry into mitosis.

Data Presentation

The following tables summarize quantitative data from various studies on the effect of EGCG on cell cycle distribution in different cancer cell lines.

Table 1: EGCG-Induced G1 Phase Arrest

Cell Line	EGCG Concentration	Treatment Duration	% of Cells in G0/G1 (Control)	% of Cells in G0/G1 (EGCG Treated)	Reference
Prostate Cancer (PC-3)	40 μ M	Not Specified	~55%	~65%	[7]
Biliary Tract Cancer (TFK-1)	Not Specified	Not Specified	8.4% (Sub-G1)	19.2% (Sub-G1)	[8]
Human Dermal Fibroblasts	200 μ mol/L	Not Specified	Not Specified	Increase in G0/G1	[9]

Table 2: EGCG-Induced G2/M Phase Arrest

Cell Line	EGCG Concentration	Treatment Duration	% of Cells in G2/M (Control)	% of Cells in G2/M (EGCG Treated)	Reference
Breast Cancer (MCF-7)	5 µg/ml	48 h	11.00 ± 1.03%	20.4 ± 2.07%	[4]
Breast Cancer (MCF-7)	20 µg/ml	48 h	11.00 ± 1.03%	28.6 ± 7.46%	[4]
Liver Cancer (HepG2)	127.09 µg/ml	48 h	Increase in S and G2/M	[10]	
Lung Cancer (A549)	10 µmol/L (with Curcumin)	24 h	Increase in S/G2	[3]	
Breast Cancer (MCF-7)	100 µM	24 h	Increase in G2/M	[11]	

Experimental Protocols

Protocol: Cell Cycle Analysis by Propidium Iodide Staining and Flow Cytometry

This protocol describes the standard procedure for preparing cells treated with EGCG for cell cycle analysis using propidium iodide (PI) staining.[12] PI is a fluorescent intercalating agent that stains DNA, allowing for the quantification of DNA content and thus the determination of the cell cycle phase.

Materials:

- Cells of interest
- EGCG (Epigallocatechin-3-gallate)

- Cell culture medium and supplements
- Phosphate-Buffered Saline (PBS), ice-cold
- 70% Ethanol, ice-cold
- Propidium Iodide (PI) staining solution (e.g., 50 µg/mL PI and 100 µg/mL RNase A in PBS)
- Flow cytometer

Procedure:

- Cell Culture and Treatment:
 - Plate cells at an appropriate density in multi-well plates.
 - Allow cells to attach and grow overnight.
 - Treat cells with the desired concentrations of EGCG or a vehicle control for the specified duration (e.g., 24, 48 hours).
- Cell Harvesting and Fixation:
 - Harvest cells by trypsinization.
 - Wash the cells once with ice-cold PBS.
 - Centrifuge at 300 x g for 5 minutes and discard the supernatant.
 - Resuspend the cell pellet in a small volume of ice-cold PBS.
 - While gently vortexing, add ice-cold 70% ethanol dropwise to the cell suspension to a final concentration of 70%.
 - Fix the cells at -20°C for at least 2 hours. Cells can be stored at -20°C for several weeks.
- Staining:
 - Centrifuge the fixed cells at 500 x g for 5 minutes to pellet the cells.

- Carefully decant the ethanol.
- Wash the cell pellet twice with ice-cold PBS.
- Resuspend the cell pellet in 500 μ L of PI staining solution.
- Incubate in the dark at room temperature for 30 minutes.
- Flow Cytometry Analysis:
 - Analyze the stained cells using a flow cytometer.
 - Excite the PI at 488 nm and measure the emission at \sim 617 nm.
 - Collect data from at least 10,000 cells per sample.
 - Use appropriate software to analyze the cell cycle distribution based on the DNA content (fluorescence intensity). The G0/G1 peak will have the lowest fluorescence, followed by the S phase, and the G2/M peak will have approximately twice the fluorescence of the G0/G1 peak.

Mandatory Visualization

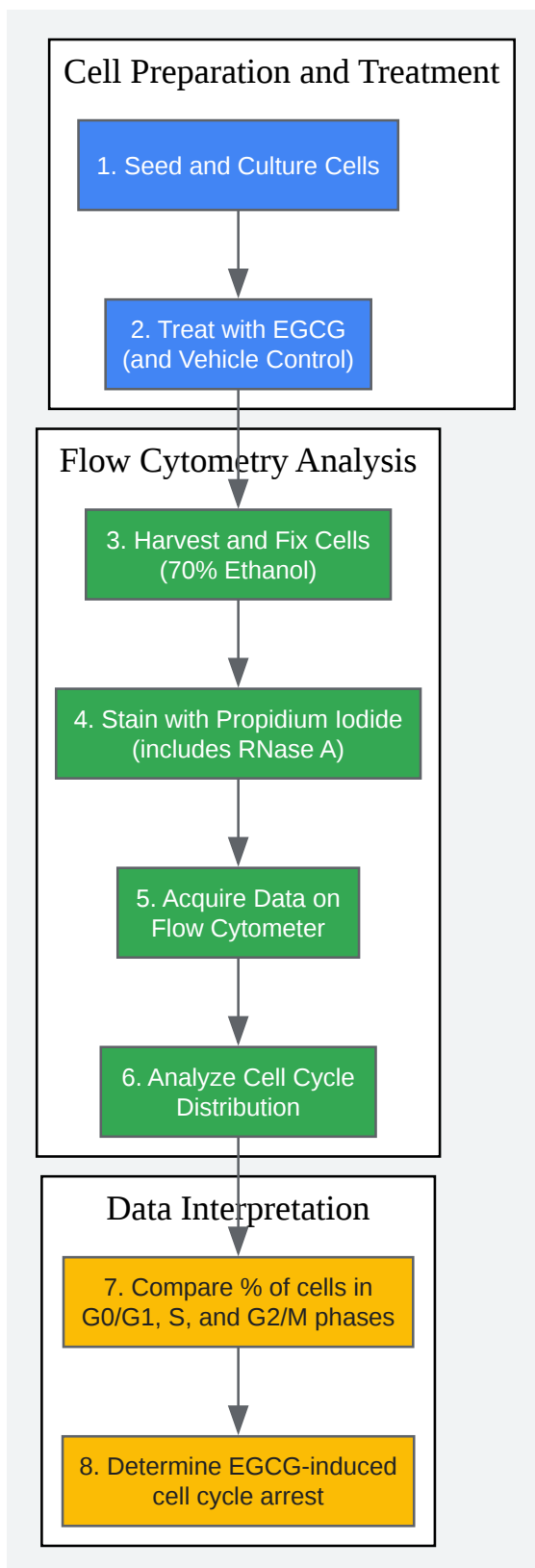

[Click to download full resolution via product page](#)

Caption: Experimental workflow for analyzing EGCG-induced cell cycle arrest.

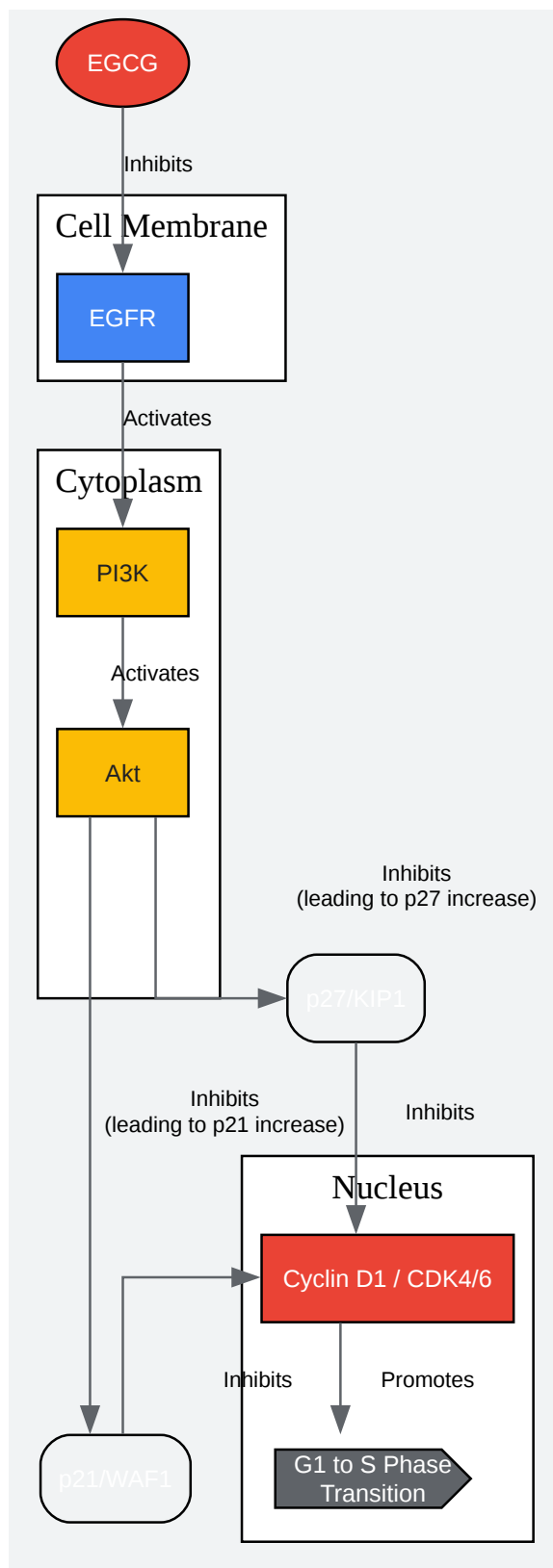

[Click to download full resolution via product page](#)

Caption: Signaling pathway of EGCG-induced G1 phase cell cycle arrest.

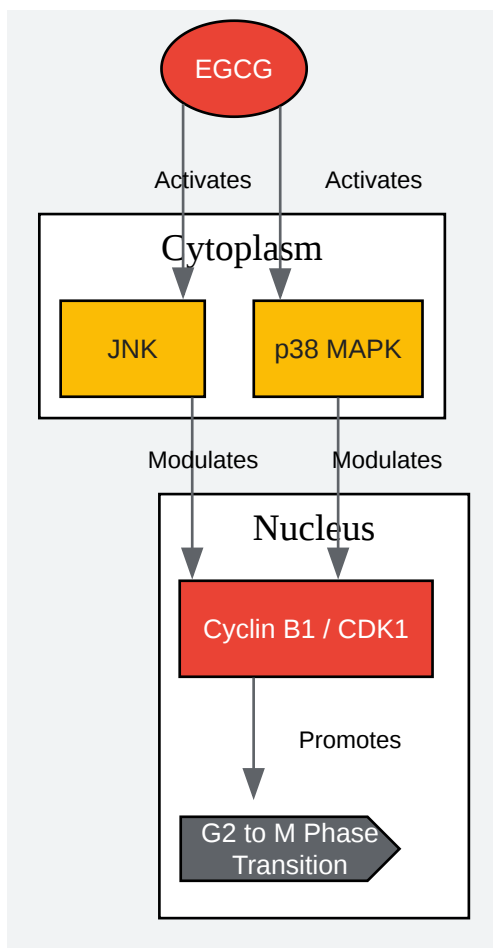

[Click to download full resolution via product page](#)

Caption: Signaling pathway of EGCG-induced G2/M phase cell cycle arrest.

Need Custom Synthesis?

BenchChem offers custom synthesis for rare earth carbides and specific isotopic labeling.

Email: info@benchchem.com or [Request Quote Online](#).

References

- 1. benchchem.com [benchchem.com]
- 2. benchchem.com [benchchem.com]
- 3. mdpi.com [mdpi.com]

- 4. Epigallocatechin gallate (EGCG) suppresses growth and tumorigenicity in breast cancer cells by downregulation of miR-25 - PMC [[pmc.ncbi.nlm.nih.gov](https://pubmed.ncbi.nlm.nih.gov)]
- 5. Molecular pathway for (-)-epigallocatechin-3-gallate-induced cell cycle arrest and apoptosis of human prostate carcinoma cells - PubMed [pubmed.ncbi.nlm.nih.gov]
- 6. [mdpi.com](https://www.mdpi.com) [[mdpi.com](https://www.mdpi.com)]
- 7. [mdpi.com](https://www.mdpi.com) [[mdpi.com](https://www.mdpi.com)]
- 8. The green tea catechin epigallocatechin gallate induces cell cycle arrest and shows potential synergism with cisplatin in biliary tract cancer cells - PMC [[pmc.ncbi.nlm.nih.gov](https://pubmed.ncbi.nlm.nih.gov)]
- 9. Epigallocatechin-3-gallate regulates cell growth, cell cycle and phosphorylated nuclear factor-κB in human dermal fibroblasts - PMC [[pmc.ncbi.nlm.nih.gov](https://pubmed.ncbi.nlm.nih.gov)]
- 10. [researchgate.net](https://www.researchgate.net) [[researchgate.net](https://www.researchgate.net)]
- 11. [researchgate.net](https://www.researchgate.net) [[researchgate.net](https://www.researchgate.net)]
- 12. Flow cytometry with PI staining | Abcam [[abcam.com](https://www.abcam.com)]
- To cite this document: BenchChem. [Application Notes: Flow Cytometry Analysis of Cell Cycle Arrest by EGCG]. BenchChem, [2026]. [Online PDF]. Available at: [<https://www.benchchem.com/product/b7765708/docs#application-notes-flow-cytometry-analysis-of-cell-cycle-arrest-by-egcg>]

Disclaimer & Data Validity:

The information provided in this document is for Research Use Only (RUO) and is strictly not intended for diagnostic or therapeutic procedures. While BenchChem strives to provide accurate protocols, we make no warranties, express or implied, regarding the fitness of this product for every specific experimental setup.

Technical Support: The protocols provided are for reference purposes. Unsure if this reagent suits your experiment?

Need Industrial/Bulk Grade? [Request Custom Synthesis Quote](#)

BenchChem

Our mission is to be the trusted global source of essential and advanced chemicals, empowering scientists and researchers to drive progress in science and industry.

Contact

Address: 3281 E Guasti Rd

Ontario, CA 91761, United States

Phone: (601) 213-4426

Email: info@benchchem.com

[Contact our Ph.D. Support Team for a compatibility check](#)