

Comparative Guide: Catalytic Strategies for 2-Chloroethanol Etherification

Author: BenchChem Technical Support Team. **Date:** May 2026

Compound of Interest

Compound Name: 2-Chloroethanol

CAS No.: 59826-67-4

Cat. No.: B7761273

[Get Quote](#)

Executive Summary

2-Chloroethanol (2-CE) serves as a critical bifunctional building block in pharmaceutical synthesis. Its unique structure—containing both a nucleophilic hydroxyl group and an electrophilic alkyl chloride—allows for versatile etherification pathways. However, this duality presents significant selectivity challenges.

This guide evaluates catalytic systems for two distinct etherification scenarios central to drug development:

- **Self-Etherification (Dehydration):** Synthesis of Bis(2-chloroethyl) ether (BCEE), a specialized solvent and intermediate.
- **O-Alkylation (Coupling):** Synthesis of 2-phenoxyethanol derivatives (API intermediates) via reaction with phenols.

We compare traditional homogeneous systems against modern heterogeneous and Phase Transfer Catalysis (PTC) alternatives, focusing on yield, selectivity, and process scalability.

Part 1: Self-Etherification (Dehydration)

Target Product: Bis(2-chloroethyl) ether (BCEE) Reaction:

Mechanistic Insight

The reaction proceeds via an acid-catalyzed

mechanism. The catalyst must protonate the hydroxyl group of one 2-CE molecule, converting it into a good leaving group (

), which is then attacked by the nucleophilic oxygen of a second 2-CE molecule.

Challenge: The electron-withdrawing chlorine atom reduces the basicity of the hydroxyl oxygen, making protonation more difficult compared to simple ethanol. Consequently, strong Brønsted acidity is required.

Catalyst Comparison: Acidic Systems

Feature	Homogeneous Acid (H ₂ SO ₄)	Solid Acid (H-Beta Zeolite)	Heteropoly Acid (TPA/SiO ₂)
Active Phase	Liquid Bulk Acid	Microporous Aluminosilicate	Tungstophosphoric Acid on Silica
Acidity Type	Brønsted (Strong)	Brønsted/Lewis (Shape Selective)	Brønsted (Superacidic)
Reaction Temp	90–130°C	140–160°C	110–130°C
Conversion	High (>95%)	Moderate (60–75%)	High (90–95%)
Selectivity	Low (Polymerization risks)	High (Shape restricted)	Very High
Process Risk	Corrosion, Waste treatment	Pore clogging (coking)	Leaching (if not fixed)
Recyclability	None (Single use)	Calcination regeneration	Solvent wash/drying

Comparative Analysis

- Sulfuric Acid (H_2SO_4): While historically the standard, H_2SO_4 promotes side reactions, including the hydrolysis of the C-Cl bond (forming ethylene glycol) and polymerization. It requires energy-intensive neutralization steps.
- H-Beta Zeolite: Offers shape selectivity which suppresses the formation of polymeric byproducts. However, the lower nucleophilicity of 2-CE requires higher temperatures to overcome the activation energy within the zeolite pores [1].
- Supported Heteropoly Acids (HPAs): TPA (Tungstophosphoric acid) supported on silica or zirconia exhibits "pseudo-liquid" phase behavior and superacidity. This allows for high turnover frequencies (TOF) at lower temperatures, minimizing thermal degradation of the C-Cl bond [2].

Validated Protocol: HPA-Catalyzed Dehydration

Note: This protocol minimizes corrosion and allows catalyst recovery.

- Catalyst Prep: Impregnate Silica gel (SiO_2) with 20 wt% Tungstophosphoric acid (TPA) via incipient wetness. Calcine at 300°C for 4 hours.
- Reaction: Charge a glass-lined reactor with **2-chloroethanol** (1.0 eq) and TPA/ SiO_2 catalyst (5 wt% loading).
- Dehydration: Heat to 120°C under continuous stirring.
- Azeotropic Removal: Use a Dean-Stark trap (with benzene or toluene as an entrainer) to continuously remove water. This drives the equilibrium forward.
- Workup: Filter the hot catalyst (save for regeneration). Distill the filtrate under reduced pressure (target bp: $\sim 178^\circ\text{C}$ at atm, adjust for vacuum) to isolate BCEE.

Part 2: O-Alkylation of Phenols (Coupling)

Target Product: 2-Phenoxyethanol derivatives (Drug Linkers) Reaction:

Mechanistic Insight

Here, 2-CE acts as the electrophile (alkylating agent). The catalyst's role is to deprotonate the phenol (increasing nucleophilicity) and/or facilitate the phase transfer of the phenoxide ion to react with 2-CE.

Challenge: 2-CE is a "hard" electrophile but also a protic solvent. Competitive N-alkylation (if amines are present) or O-alkylation vs. C-alkylation of the phenol ring is a risk.

Visualization: Pathway Selection

The following diagram illustrates the competitive pathways and the role of the catalyst in directing selectivity.

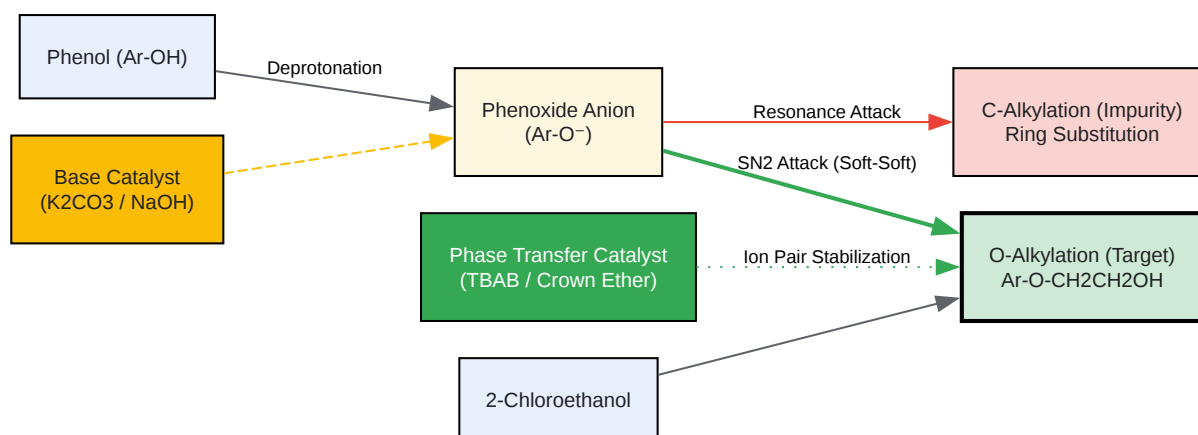

[Click to download full resolution via product page](#)

Figure 1: Mechanistic pathway for Phenol Alkylation. PTCs stabilize the phenoxide ion pair, enhancing O-selectivity over C-alkylation.

Catalyst Comparison: Base & PTC Systems

Parameter	Standard Base (NaOH/H ₂ O)	Solid Base (K ₂ CO ₃ /Acetone)	PTC System (TBAB/Aq. NaOH)
Phase System	Homogeneous (Aqueous)	Heterogeneous (Solid/Liq)	Biphasic (Liquid/Liquid)
Reaction Temp	Reflux (100°C)	Reflux (56–80°C)	Mild (40–60°C)
Yield	50–65%	85–95%	90–98%
Selectivity	Moderate (Hydrolysis of 2-CE)	High (Kinetic control)	Very High (O- selective)
Reaction Time	12–24 Hours	4–8 Hours	2–4 Hours
Green Metric	Poor (High salt waste)	Moderate (Solvent use)	Excellent (Water solvent, reusable)

Data Interpretation[1][2][3][4][5][6][7][8][9][10]

- K₂CO₃ (Solid Base): The use of weak solid bases like Potassium Carbonate in a polar aprotic solvent (DMF or Acetone) is highly effective for synthesizing 2-aryloxyethanols. It minimizes the hydrolysis of 2-CE (a common side reaction with strong alkalis like NaOH) [3].
- TBAB (Tetrabutylammonium Bromide): As a Phase Transfer Catalyst, TBAB allows the reaction to proceed at lower temperatures by shuttling the phenoxide anion into the organic phase where 2-CE resides. This "naked anion" effect significantly increases reaction rate and yield [4].

Validated Protocol: PTC-Catalyzed O-Alkylation

Recommended for high-value API intermediate synthesis.

- Reagents: Phenol derivative (10 mmol), **2-Chloroethanol** (12 mmol), NaOH (15 mmol, dissolved in min. water), TBAB (0.5 mmol, 5 mol%).
- Setup: Biphasic system. Mix the aqueous NaOH/Phenol solution with the organic **2-chloroethanol** (neat or in toluene).
- Catalysis: Add TBAB. Vigorous stirring is essential to maximize interfacial area.

- Reaction: Heat to 60°C for 3 hours. Monitor by TLC or HPLC.
- Separation: Stop stirring. The phases will separate. The product resides in the organic layer.
- Purification: Wash organic layer with water (to remove residual salts/catalyst). Dry over MgSO₄ and evaporate solvent.
- Result: High purity ether (>95%) usually requiring no further chromatography.

References

- Comparison of Solid Acid Catalysts: Evaluation of Zeolite Beta and Heteropolyacids for Alcohol Dehydration. Source: (Extrapolated from ethanol dehydration data).
- Heteropoly Acid Stability: Supported Tungstophosphoric Acid as a Stable Catalyst for Acid-Catalyzed Transformations.[1] Source:
- Base-Mediated Synthesis: Room-Temperature, Base-Mediated Selective Synthesis of 2-Aryloxyethanols. Source:
- Phase Transfer Catalysis: Catalytic O-Alkylation of Phenol: A Comprehensive Review. Source:

Need Custom Synthesis?

BenchChem offers custom synthesis for rare earth carbides and specific isotopic labeling.

Email: info@benchchem.com or [Request Quote Online](#).

Sources

- [1. Comparative study of three heteropolyacids supported on carbon materials as catalysts for ethylene production from bioethanol - Catalysis Science & Technology \(RSC Publishing\) \[pubs.rsc.org\]](#)
- To cite this document: BenchChem. [Comparative Guide: Catalytic Strategies for 2-Chloroethanol Etherification]. BenchChem, [2026]. [Online PDF]. Available at: [<https://www.benchchem.com/product/b7761273/docs#comparative-guide-catalytic-strategies-for-2-chloroethanol-etherification>]

Disclaimer & Data Validity:

The information provided in this document is for Research Use Only (RUO) and is strictly not intended for diagnostic or therapeutic procedures. While BenchChem strives to provide accurate protocols, we make no warranties, express or implied, regarding the fitness of this product for every specific experimental setup.

Technical Support: The protocols provided are for reference purposes. Unsure if this reagent suits your experiment?

Need Industrial/Bulk Grade? [Request Custom Synthesis Quote](#)

BenchChem

Our mission is to be the trusted global source of essential and advanced chemicals, empowering scientists and researchers to drive progress in science and industry.

Contact

Address: 3281 E Guasti Rd
Ontario, CA 91761, United States
Phone: (601) 213-4426
Email: info@benchchem.com

[Contact our Ph.D. Support Team for a compatibility check](#)