

A Comparative Analysis of L-Methionine Metabolic Flux: A Guide for Researchers

Author: BenchChem Technical Support Team. **Date:** December 2025

Compound of Interest

Compound Name: *L-Methionine*

Cat. No.: *B7761469*

[Get Quote](#)

For researchers, scientists, and drug development professionals, understanding the metabolic flux of **L-Methionine** is critical for dissecting cellular physiology in both healthy and diseased states. This guide provides a comparative analysis of **L-Methionine** metabolism, supported by experimental data and detailed protocols, to facilitate further research and therapeutic development.

Methionine, an essential amino acid, plays a central role in cellular metabolism beyond its function in protein synthesis. It is a key donor of methyl groups for the methylation of DNA, proteins, and other molecules, and a precursor for the synthesis of polyamines and cysteine.[1] [2] The intricate network of reactions involving methionine, known as the methionine cycle, is fundamental for cellular growth, redox balance, and epigenetic regulation.[3] Dysregulation of this pathway has been implicated in various diseases, including cancer.[3][4]

This guide will delve into the quantitative analysis of **L-methionine** metabolic flux, comparing metabolic activities in different cellular contexts and providing the necessary experimental frameworks for such investigations.

L-Methionine Metabolic Pathways

The metabolism of **L-methionine** is primarily centered around the methionine cycle and its interconnected pathways, including the transsulfuration pathway and polyamine synthesis. A critical aspect of this is the generation of S-adenosylmethionine (SAM), the universal methyl donor.[3]

Below is a diagram illustrating the core pathways of **L-methionine** metabolism.

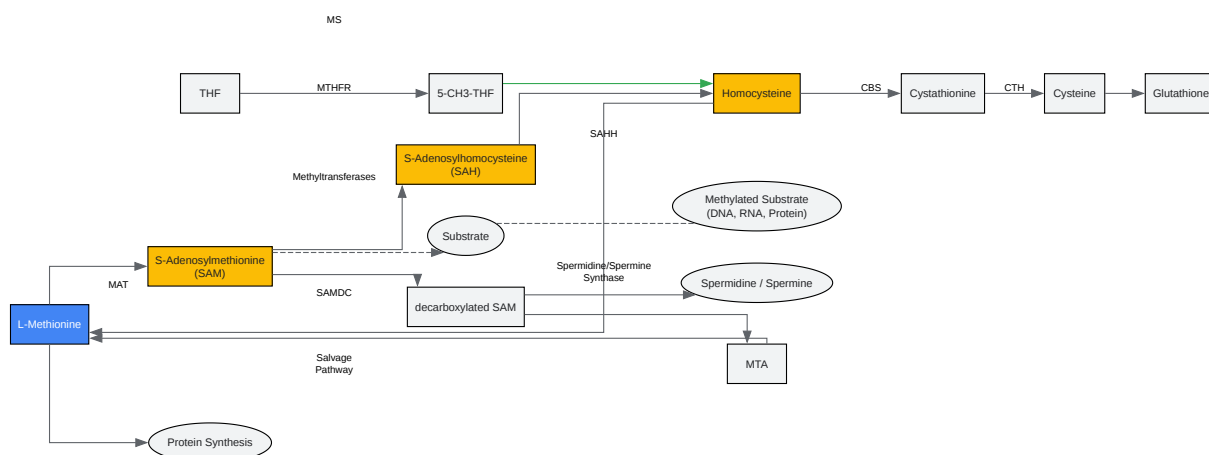

[Click to download full resolution via product page](#)

Caption: Core pathways of **L-Methionine** metabolism.

Comparative Metabolic Flux Data

A key technique for quantifying the rates of metabolic reactions is stable isotope tracing, coupled with mass spectrometry.[5] This approach allows for the precise measurement of metabolite turnover. Below is a summary of **L-methionine** metabolic flux data from a study on a human fibrosarcoma cell line (HT1080), comparing cells with and without the expression of

methylthioadenosine phosphorylase (MTAP), an enzyme in the methionine salvage pathway that is often deleted in cancer.[5]

| Reaction (Flux) | HT1080M+ (nmol/ μL-cells/h) | HT1080M- (nmol/ μL-cells/h) | Description |
|------------------------------|--------------------------------|--------------------------------|---|
| v1 (vmet_in – vmet_out) | 0.8 ± 0.1 | 0.9 ± 0.1 | Net methionine uptake |
| v2 (Propylamine transfer) | 0.17 ± 0.02 | 0.11 ± 0.01 | Flux towards polyamine synthesis |
| v3 (Methionine salvage) | 0.17 ± 0.02 | 0 | Flux through the MTAP-dependent salvage pathway |
| v4 (Transmethylation) | 0.12 ± 0.02 | 0.16 ± 0.02 | Total flux of methyl group donation from SAM |
| v5 (Methionine synthase) | 0.03 ± 0.02 | 0.02 ± 0.01 | Remethylation of homocysteine to methionine |

Data sourced from: Liu et al. (2014). Quantitation of Cellular Metabolic Fluxes of Methionine. Analytical Chemistry.[5]

This data reveals that in these cancer cells, both transmethylation and propylamine transfer fluxes represent a significant portion (around 15%) of the net methionine uptake.[5] Notably, the deletion of MTAP ablates the methionine salvage pathway flux (v3) and is associated with a more than two-fold increase in the flux through ornithine decarboxylase (a key enzyme in polyamine synthesis).[5]

Experimental Protocols for L-Methionine Flux Analysis

The following is a generalized protocol for conducting **L-methionine** metabolic flux analysis using stable isotope tracing.

Cell Culture and Isotope Labeling

- **Cell Seeding:** Plate cells at a density that ensures they remain in the exponential growth phase throughout the experiment.
- **Isotope Switch:** At the start of the experiment, replace the standard culture medium with a medium containing a stable isotope-labeled form of **L-methionine**, typically **¹³C5-L-methionine**.^[5]
- **Time-Course Sampling:** Collect samples of both the cell culture medium and the intracellular metabolites at multiple time points to capture the kinetics of isotope incorporation.^[5]

Metabolite Extraction

- **Media Removal:** Aspirate the culture medium.
- **Cell Washing:** Quickly wash the cells with ice-cold phosphate-buffered saline (PBS) to remove any remaining extracellular metabolites.
- **Metabolism Quenching and Extraction:** Immediately add a pre-chilled extraction solvent (e.g., 80:20 methanol/water at -80°C) to the cells to halt all enzymatic activity and extract the metabolites.^[5]

LC-MS Analysis

- **Sample Preparation:** Centrifuge the cell extracts to pellet any debris and transfer the supernatant for analysis.
- **Liquid Chromatography-Mass Spectrometry (LC-MS):** Analyze the samples using LC-MS to separate and quantify the different isotopologues of methionine and its downstream metabolites.^[5]
- **Data Acquisition:** Measure the fractional labeling of each metabolite at each time point.

Metabolic Flux Calculation

- **Computational Modeling:** Utilize computational models and software (e.g., based on ordinary differential equations or metabolic flux analysis frameworks) to fit the isotope labeling kinetics

data.[5][6]

- Flux Determination: From the model, calculate the rates (fluxes) of the individual reactions in the methionine metabolic network.[5]

The following diagram outlines the general workflow for this experimental approach.

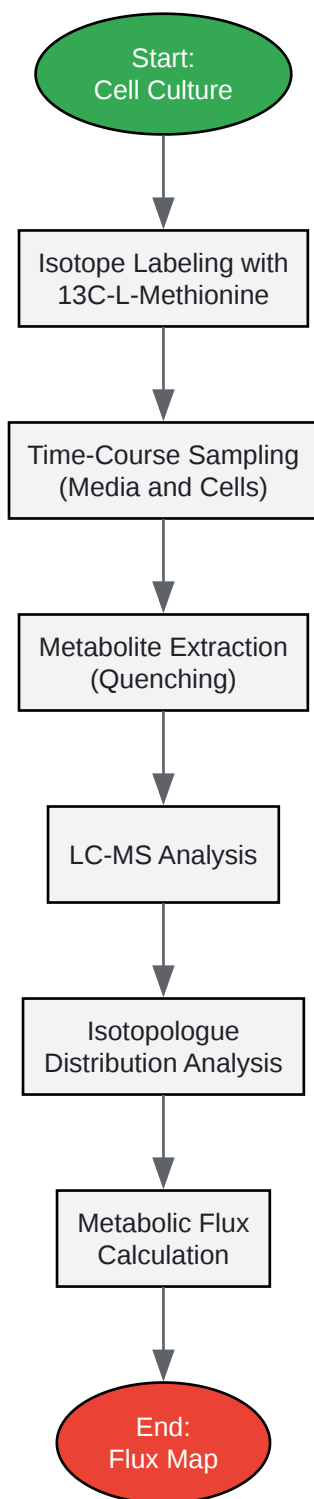

[Click to download full resolution via product page](#)

Need Custom Synthesis?

BenchChem offers custom synthesis for rare earth carbides and specific isotopic labeling.

Email: info@benchchem.com or [Request Quote Online](#).

References

- 1. pubs.acs.org [pubs.acs.org]
- 2. Quantitation of cellular metabolic fluxes of methionine - PubMed [pubmed.ncbi.nlm.nih.gov]
- 3. Methionine Cycle Analysis Service - Creative Proteomics [creative-proteomics.com]
- 4. Sensing and Signaling of Methionine Metabolism - PMC [pmc.ncbi.nlm.nih.gov]
- 5. Quantitation of Cellular Metabolic Fluxes of Methionine - PMC [pmc.ncbi.nlm.nih.gov]
- 6. Computational modeling of methionine cycle-based metabolism and DNA methylation and the implications for anti-cancer drug response prediction - PMC [pmc.ncbi.nlm.nih.gov]
- To cite this document: BenchChem. [A Comparative Analysis of L-Methionine Metabolic Flux: A Guide for Researchers]. BenchChem, [2025]. [Online PDF]. Available at: [<https://www.benchchem.com/product/b7761469#comparative-analysis-of-l-methionine-metabolic-flux>]

Disclaimer & Data Validity:

The information provided in this document is for Research Use Only (RUO) and is strictly not intended for diagnostic or therapeutic procedures. While BenchChem strives to provide accurate protocols, we make no warranties, express or implied, regarding the fitness of this product for every specific experimental setup.

Technical Support: The protocols provided are for reference purposes. Unsure if this reagent suits your experiment? [[Contact our Ph.D. Support Team for a compatibility check](#)]

Need Industrial/Bulk Grade? [Request Custom Synthesis Quote](#)

BenchChem

Our mission is to be the trusted global source of essential and advanced chemicals, empowering scientists and researchers to drive progress in science and industry.

Contact

Address: 3281 E Guasti Rd

Ontario, CA 91761, United States

Phone: (601) 213-4426

Email: info@benchchem.com