

Magnoflorine: A Comprehensive Guide to its Natural Sources, Distribution, and Analysis

Author: BenchChem Technical Support Team. **Date:** April 2026

Compound of Interest

Compound Name: *Magnoflorine;alpha-Magnoflorine;Thalictrine*

Cat. No.: *B7759909*

[Get Quote](#)

Abstract: Magnoflorine, a quaternary aporphine alkaloid of the isoquinoline class, is a widely distributed secondary metabolite in the plant kingdom, attracting significant attention for its diverse pharmacological activities. This technical guide provides an in-depth exploration of the natural sources, botanical distribution, biosynthesis, and the analytical methodologies crucial for its isolation and quantification. We will delve into the causality behind experimental choices in extraction and analysis, presenting validated protocols and comparative data to support researchers, scientists, and drug development professionals in their work with this promising natural compound.

Introduction to Magnoflorine: A Bioactive Aporphine Alkaloid

Magnoflorine ($C_{20}H_{24}NO_4^+$) is a water-soluble quaternary aporphine alkaloid that is prevalent across numerous plant families. Its structure is derived from the N-methylation of (S)-corytuberine, resulting in a permanent positive charge on the nitrogen atom. This structural feature significantly influences its solubility and pharmacokinetic profile. The compound is recognized for a wide spectrum of biological activities, including anti-inflammatory, antioxidant, antidiabetic, neuroprotective, and anticancer properties, making it a molecule of high interest

for therapeutic development. Understanding its natural distribution is the first critical step in harnessing its potential, from initial phytochemical screening to the development of standardized herbal medicines or purified drug candidates.

Botanical Distribution of Magnoflorine

Magnoflorine is one of the most widely distributed aporphine alkaloids, having been identified in approximately 20 botanical families. Its presence is particularly concentrated in the roots, rhizomes, stems, and bark of plants. The primary families known for producing magnoflorine include Berberidaceae, Magnoliaceae, Papaveraceae, Menispermaceae, and Ranunculaceae.

Below is a summary table of representative plant species documented to contain magnoflorine, highlighting the extensive taxonomic distribution of this alkaloid.

Botanical Family	Genus	Species	Common Name(s)	Reference(s)
Berberidaceae	Berberis	B. vulgaris, B. crataegina, B. pachyacantha	Barberry	
Mahonia	M. aquifolium, M. napaulensis	Oregon Grape		
Caulophyllum	C. thalictroides	Blue Cohosh		
Menispermaceae	Tinospora	T. cordifolia, T. crispa	Guduchi, Giloy	
Sinomenium	S. acutum	Chinese Moonseed		
Stephania	S. tetrandra, S. elegans, S. hernandiifolia			
Magnoliaceae	Magnolia	M. officinalis, M. grandiflora	Magnolia	
Papaveraceae	Papaver	P. argemone, P. rhoeas	Poppy	
Glaucium	G. flavum	Yellow Horned Poppy		
Ranunculaceae	Coptis	C. chinensis, C. teeta	Goldthread	
Thalictrum	T. isopyroides	Meadow-rue		
Aquilegia	A. fragrans, A. moorcroftiana	Columbine		
Clematis	C. parviloba, C. gouriana	Clematis		
Annonaceae	Annona	A. glabra	Pond Apple	

Aristolochiaceae	Aristolochia	A. contorta, A. bracteolata	
Rutaceae	Phellodendron	P. amurense, P. chinense	Amur Cork Tree
Rhamnaceae	Ziziphus	Z. jujuba	Jujube

The Biosynthetic Pathway of Magnoflorine

Magnoflorine originates from the benzylisoquinoline alkaloid (BIA) pathway, a well-studied metabolic route in plants. The biosynthesis begins with the amino acid L-tyrosine. The critical steps leading to the aporphine core of magnoflorine involve the intramolecular C-C phenol coupling of (S)-reticuline, a key branch-point intermediate in BIA metabolism. This reaction is catalyzed by a specific cytochrome P450 enzyme, CYP80G2, to form (S)-corytuberine. The final step is the quaternization of the nitrogen atom in (S)-corytuberine by an N-methyltransferase to yield magnoflorine.

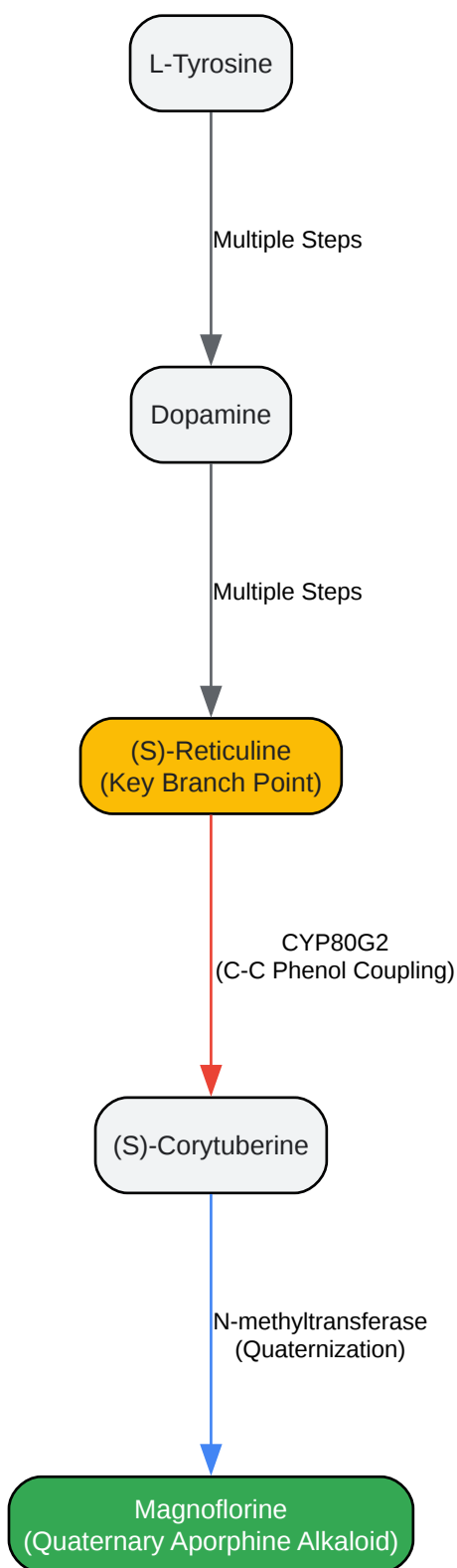

[Click to download full resolution via product page](#)

Caption: Biosynthetic pathway of magnoflorine from L-tyrosine.

Methodologies for Extraction, Isolation, and Quantification

The successful study of magnoflorine hinges on robust and validated methods for its extraction from complex plant matrices, followed by efficient isolation and accurate quantification.

Extraction and Isolation Protocols

Due to its quaternary ammonium structure, magnoflorine is highly polar and water-soluble. This property dictates the choice of solvents and chromatographic techniques. Methanol or ethanol are commonly used for initial extraction. Advanced techniques like Pressurized Liquid Extraction (PLE), also known as Accelerated Solvent Extraction (ASE), can enhance efficiency.

For isolation, traditional silica gel chromatography can be challenging due to the strong adsorption of this nitrogen-containing compound. Counter-Current Partition Chromatography (CPC) has emerged as a highly effective alternative. CPC is a liquid-liquid chromatography technique that avoids solid supports, thereby preventing irreversible adsorption and leading to higher recovery and purity.

Protocol: Isolation of Magnoflorine from *Berberis vulgaris* Root via CPC

This protocol is adapted from methodologies proven effective for isolating magnoflorine.

- Extraction:
 1. Grind dried *Berberis vulgaris* root material to a fine powder (40-60 mesh).
 2. Perform pressurized liquid extraction (PLE/ASE) with methanol under the following conditions: temperature at 80-90°C, pressure at 95-100 bar, with 3-4 static cycles of 10 minutes each.
 3. Combine the methanolic extracts and evaporate to dryness under reduced pressure to yield a crude extract residue.
- CPC Solvent System Selection:

1. The choice of a biphasic solvent system is critical for successful CPC separation. A common system for aporphine alkaloids is a mixture of Chloroform:Methanol:Water (e.g., 4:3:3 v/v) or Ethyl Acetate:Butanol:Water (e.g., 0.6:1.5:3 v/v/v).
 2. Determine the partition coefficient (k) for magnoflorine in several candidate systems. The ideal k -value is between 0.5 and 2.0. This is achieved by dissolving a small amount of crude extract in a test tube with the biphasic system, shaking vigorously, and analyzing the concentration of magnoflorine in each phase via HPLC.
- CPC Separation:
 1. Equilibrate the CPC column by pumping the stationary phase (typically the more polar, aqueous phase for magnoflorine) until the column is full.
 2. Initiate column rotation to the desired speed (e.g., 1600 rpm).
 3. Pump the mobile phase (the less polar, organic phase) through the column until hydrodynamic equilibrium is reached (i.e., when the stationary phase stops eluting).
 4. Dissolve the crude extract (e.g., 300 mg) in a minimal volume of the solvent system and inject it into the column.
 5. Perform the separation in elution mode, collecting fractions based on UV detection (e.g., at 254 and 290 nm).
 6. Analyze the collected fractions by TLC or HPLC to identify those containing pure magnoflorine. Combine the pure fractions and evaporate the solvent to obtain the isolated compound. Purity is typically confirmed via HPLC-MS.

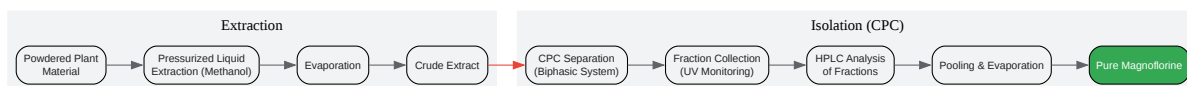

[Click to download full resolution via product page](#)

Caption: General workflow for extraction and isolation of magnoflorine.

Analytical and Quantification Methodologies

Accurate quantification of magnoflorine in plant extracts, dietary supplements, and biological samples is essential for quality control and pharmacological studies. High-Performance Liquid Chromatography (HPLC) and Ultra-Performance Liquid Chromatography (UPLC) are the most common techniques employed.

Method Comparison: HPLC-UV vs. UPLC-MS

Parameter	HPLC-UV / UPLC-PDA	UPLC-MS/MS
Principle	Separation based on polarity, detection via UV absorbance.	Separation based on polarity, detection via mass-to-charge ratio.
Selectivity	Good. Potential for co-elution with compounds having similar retention times and UV spectra.	Excellent. Highly specific identification based on parent and fragment ions.
Sensitivity	Good. Limit of Detection (LOD) typically around 1 µg/mL.	Excellent. Much lower LODs, suitable for trace analysis.
Run Time	HPLC: ~35 min; UPLC: ~8 min.	UPLC: ~8 min or less.
Application	Routine quality control, quantification in high-concentration samples.	Metabolite profiling, pharmacokinetics, confirmation of identity, quantification in complex matrices.
Cost	Lower initial and operational cost.	Higher initial and operational cost.

Protocol: UPLC-PDA Quantification of Magnoflorine

This protocol is based on established and validated methods for magnoflorine analysis.

- Sample Preparation:
 1. Accurately weigh the powdered plant material or dietary supplement.
 2. Extract with methanol using sonication for 30 minutes.
 3. Centrifuge the mixture at 4000 rpm for 10 minutes.
 4. Filter the supernatant through a 0.22 μm syringe filter into an HPLC vial.

- Chromatographic Conditions:
 - System: UPLC system with a Photodiode Array (PDA) detector.
 - Column: Reversed-phase C18 column (e.g., UPLC BEH C18, 2.1 x 100 mm, 1.7 μm).
 - Mobile Phase: A gradient elution using (A) ammonium acetate buffer or 0.1% formic acid in water and (B) acetonitrile.
 - Flow Rate: Approximately 0.3-0.5 mL/min.
 - Detection: Monitor at a wavelength of 320 nm, where magnoflorine has a distinct absorbance maximum.
 - Column Temperature: 25-30°C.

- Quantification:
 1. Prepare a stock solution of a certified magnoflorine reference standard.
 2. Create a calibration curve by preparing a series of dilutions from the stock solution and injecting them into the UPLC system.
 3. Plot the peak area against the concentration to establish a linear regression.
 4. Inject the prepared sample, identify the magnoflorine peak by comparing its retention time and UV spectrum to the standard, and calculate the concentration in the sample using the calibration curve.

- Confirmation (via LC-MS):
 - For unequivocal identification, especially in complex matrices, LC-MS is the gold standard.
 - Magnoflorine produces a parent ion $[M]^+$ at m/z 342.17 in positive electrospray ionization (ESI) mode.
 - Key fragment ions for confirmation include signals at m/z 311, 297, and 282.

Conclusion and Future Perspectives

Magnoflorine is a ubiquitously distributed aporphine alkaloid with significant therapeutic potential. Its presence across a wide array of plant families, particularly Berberidaceae, Menispermaceae, and Magnoliaceae, offers numerous avenues for its sourcing. The methodologies outlined in this guide, from efficient extraction and isolation using techniques like CPC to precise quantification via UPLC, provide a robust framework for researchers.

Future work should focus on screening a wider range of botanicals to identify novel, high-yielding sources of magnoflorine. Furthermore, metabolic engineering and plant cell culture techniques present exciting opportunities for sustainable and scalable production of this valuable alkaloid, bypassing the limitations of agricultural sourcing and paving the way for its broader application in drug development.

References

- To cite this document: BenchChem. [Magnoflorine: A Comprehensive Guide to its Natural Sources, Distribution, and Analysis]. BenchChem, [2026]. [Online PDF]. Available at: [\[https://www.benchchem.com/product/b7759909/docs#magnoflorine-a-comprehensive-guide-to-its-natural-sources-distribution-and-analysis\]](https://www.benchchem.com/product/b7759909/docs#magnoflorine-a-comprehensive-guide-to-its-natural-sources-distribution-and-analysis)

Disclaimer & Data Validity:

The information provided in this document is for Research Use Only (RUO) and is strictly not intended for diagnostic or therapeutic procedures. While BenchChem strives to provide accurate protocols, we make no warranties, express or implied, regarding the fitness of this product for every specific experimental setup.

Technical Support: The protocols provided are for reference purposes. Unsure if this reagent suits your experiment?

Need Industrial/Bulk Grade? [Request Custom Synthesis Quote](#)

BenchChem

Our mission is to be the trusted global source of essential and advanced chemicals, empowering scientists and researchers to drive progress in science and industry.

Contact

Address: 3281 E Guasti Rd
Ontario, CA 91761, United States
Phone: (601) 213-4426
Email: info@benchchem.com

[Contact our Ph.D. Support Team for a compatibility check](#)