

Technical Whitepaper: Spectroscopic Elucidation of 1-Aminopentan-2-ol

Author: BenchChem Technical Support Team. **Date:** May 2026

Compound of Interest

Compound Name: 1-Aminopentan-2-ol

CAS No.: 189769-47-9

Cat. No.: B7721184

[Get Quote](#)

Executive Summary & Structural Context

This guide details the structural validation of **1-aminopentan-2-ol** (

), a critical

-amino alcohol pharmacophore. Often encountered as a chiral intermediate in the synthesis of adrenergic blockers and sphingosine mimetics, its analysis requires a nuanced understanding of stereochemical effects on spectroscopy.

The molecule features a chiral center at C2, creating a specific challenge in NMR analysis: the diastereotopicity of the adjacent C1 methylene protons. This guide moves beyond basic peak assignment to explain the causality of spectral anomalies and provides self-validating protocols for rigorous identification.

Mass Spectrometry (MS): The Fragmentation Fingerprint

Objective: Confirm molecular weight and the 1,2-amino alcohol connectivity.

Ionization & Molecular Ion

- Technique: Electrospray Ionization (ESI) in Positive Mode is preferred for the parent ion, while Electron Impact (EI) is required for structural fingerprinting.
- Nitrogen Rule: The molecular weight is 103.16 Da (odd number). An odd molecular ion () confirms the presence of an odd number of nitrogen atoms (1).
- Base Peak Logic: In -amino alcohols, the nitrogen atom directs fragmentation more strongly than oxygen due to its lower ionization potential.

Characteristic Fragmentation (EI-MS)

The dominant pathway is

-cleavage adjacent to the heteroatoms.

Fragment Ion	m/z	Mechanism	Diagnostic Value
Base Peak	30	-cleavage at C1-C2 bond (Amine directed)	Definitive. Corresponds to the iminium ion. Confirms a primary amine on a terminal carbon ().
Secondary Peak	60	-cleavage at C2-C3 bond (Alcohol directed)	Corresponds to. Confirms the propyl tail loss (). ^[1]
Molecular Ion	103	Radical Cation	Often weak or absent in EI due to rapid fragmentation; clearly visible as (104) in ESI.

Visualization of Fragmentation Pathway

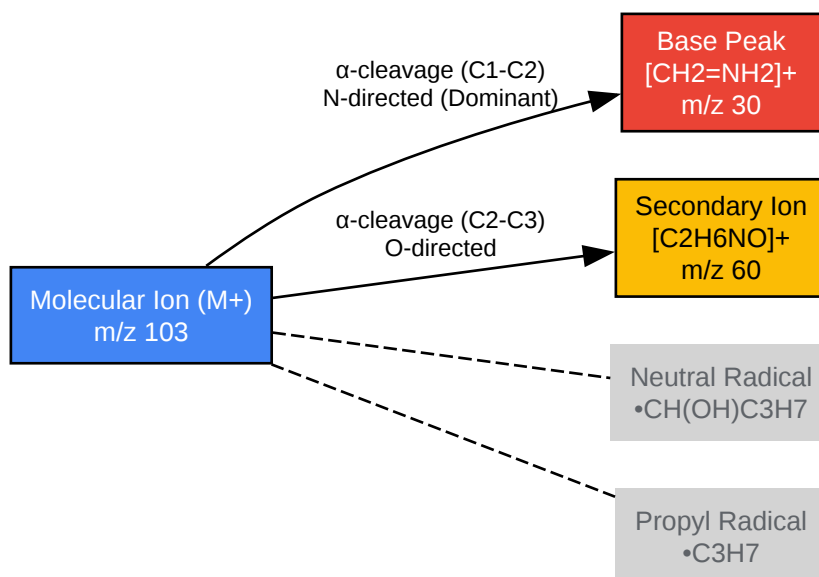

[Click to download full resolution via product page](#)

Figure 1: Competitive

-cleavage pathways. The formation of m/z 30 is kinetically favored.

Infrared Spectroscopy (IR): Functional Group Validation

Objective: Distinguish the amine/alcohol dual functionality and assess hydrogen bonding.

Spectral Interpretation

The key challenge is the overlap of N-H and O-H stretching regions.

- Region 3200–3500 cm^{-1} (The "Active" Zone):
 - O-H Stretch: Appears as a broad, strong band centered $\sim 3350 \text{ cm}^{-1}$ due to intermolecular hydrogen bonding.
 - N-H Stretch: Primary amines exhibit two bands (symmetric/asymmetric). In **1-aminopentan-2-ol**, these are often observed as two weak "spikes" superimposed on the broad O-H shoulder at ~ 3300 and $\sim 3380 \text{ cm}^{-1}$.
- Fingerprint Region:
 - C-O Stretch: Strong band at 1050–1100 cm^{-1} (secondary alcohol).
 - N-H Scissoring: Medium band at $\sim 1600 \text{ cm}^{-1}$ (distinguishes amine from pure alcohol).

Nuclear Magnetic Resonance (NMR): The Stereochemical Deep Dive

Objective: Confirm the carbon skeleton and resolve the diastereotopic protons at C1.

Experimental Protocol: Solvent Selection

- Routine (

): Good for carbon backbone. Labile protons (OH, NH₂) often appear as broad singlets that shift with concentration.

- Expert Choice (

): Recommended. The high polarity slows proton exchange, often allowing observation of the OH coupling (doublet) and distinct NH₂ signals.

- Validation Step (

Shake): After acquiring the standard spectrum, add 1 drop of

. The disappearance of OH and NH₂ signals confirms their assignment.

1H NMR Assignment (500 MHz,)

Note: Chemical shifts (

) are approximate and concentration-dependent.

Position	Group	(ppm)	Multiplicity	Integration	Expert Insight (Causality)
C5		0.92	Triplet (Hz)	3H	Terminal methyl, unperturbed.
C3, C4		1.3 – 1.5	Multiplet	4H	Overlapping alkyl chain signals.
C1		2.6 – 2.9	dd or ABX	2H	<p>Critical Feature: These protons are diastereotopic due to the adjacent chiral center at C2. They are chemically non-equivalent () and couple to each other () and the C2 methine ().</p>
C2		3.5 – 3.7	Multiplet	1H	<p>Deshielded by oxygen. Complexity arises from coupling to</p>

C1(
) and C3(
).

OH/NH₂

Labile

2.0 – 4.0

Broad Singlet

3H

Highly
 variable. Use
 exchange to
 verify.

The Diastereotopic Effect (C1 Protons)

Because C2 is a stereocenter, the two protons on C1 reside in different magnetic environments. They do not appear as a simple doublet (which would be expected for a

next to a

).

- Appearance: Two distinct multiplets (often widely separated) or a complex "roofing" pattern.
- Coupling:
 - Geminal coupling (): Large, ~12-14 Hz.
 - Vicinal coupling (vs): Different values depending on the rotamer population (Karplus relationship).

13C NMR Data (Proton Decoupled)

Carbon	Type	(ppm)	Assignment Logic
C1		~46.0	Deshielded by N, but less than O.
C2		~73.0	Most deshielded signal (attached to Oxygen).
C3		~37.0	-shift from Oxygen.
C4		~19.0	Shielded methylene.
C5		~14.0	Typical methyl.

Structural Validation Logic Flow

This diagram illustrates the decision matrix for confirming the structure using the data described above.

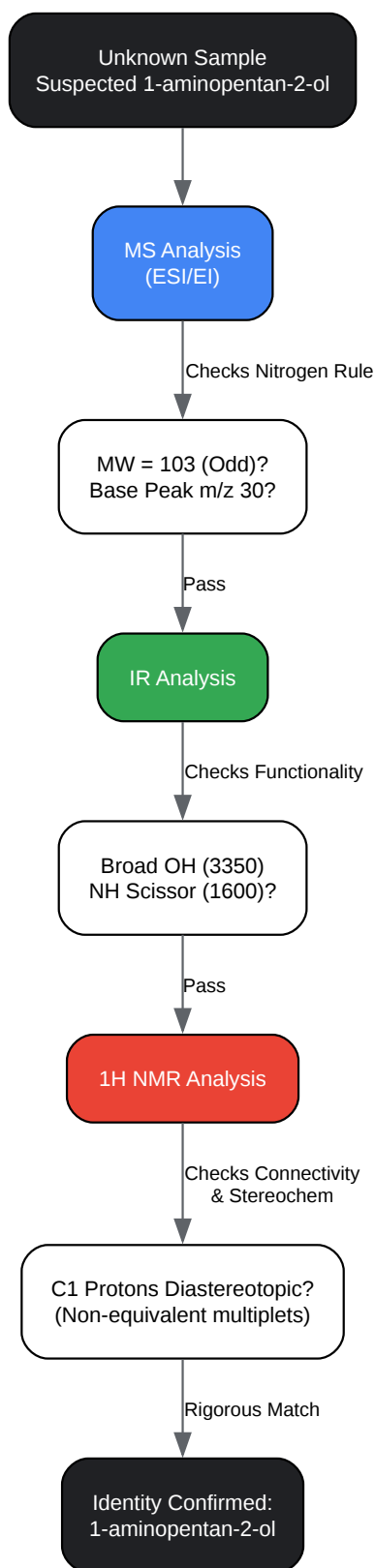

[Click to download full resolution via product page](#)

Figure 2: Step-by-step spectroscopic validation workflow.

References

- Silverstein, R. M., Webster, F. X., & Kiemle, D. J. (2005). Spectrometric Identification of Organic Compounds (7th ed.). John Wiley & Sons. (Standard text for mass spectrometry fragmentation rules and alpha-cleavage mechanisms).
- National Institute of Standards and Technology (NIST). (2023). Mass Spectrum of 1-amino-2-propanol (Analogous Beta-amino alcohol). NIST Chemistry WebBook, SRD 69. [[Link](#)]
- AIST Spectral Database for Organic Compounds (SDBS). (2023). ¹H NMR and ¹³C NMR prediction and data repository. [[Link](#)]
- Reich, H. J. (2023). Structure Determination Using NMR: Diastereotopic Protons. University of Wisconsin-Madison. [[Link](#)]

Need Custom Synthesis?

BenchChem offers custom synthesis for rare earth carbides and specific isotopic labeling.

Email: info@benchchem.com or [Request Quote Online](#).

Sources

- [1. youtube.com](https://www.youtube.com) [[youtube.com](https://www.youtube.com)]
- To cite this document: BenchChem. [Technical Whitepaper: Spectroscopic Elucidation of 1-Aminopentan-2-ol]. BenchChem, [2026]. [Online PDF]. Available at: [<https://www.benchchem.com/product/b7721184/docs#technical-whitepaper-spectroscopic-elucidation-of-1-aminopentan-2-ol>]

Disclaimer & Data Validity:

The information provided in this document is for Research Use Only (RUO) and is strictly not intended for diagnostic or therapeutic procedures. While BenchChem strives to provide accurate protocols, we make no warranties, express or implied, regarding the fitness of this product for every specific experimental setup.

Technical Support: The protocols provided are for reference purposes. Unsure if this reagent suits your experiment?

Need Industrial/Bulk Grade? [Request Custom Synthesis Quote](#)

BenchChem

Our mission is to be the trusted global source of essential and advanced chemicals, empowering scientists and researchers to drive progress in science and industry.

Contact

Address: 3281 E Guasti Rd
Ontario, CA 91761, United States
Phone: (601) 213-4426
Email: info@benchchem.com

[Contact our Ph.D. Support Team for a compatibility check](#)