

Application Note: HPMA-Based Hydrogel Scaffolds for Biomedical Applications

Author: BenchChem Technical Support Team. **Date:** May 2026

Compound of Interest

Compound Name: 2-Hydroxypropyl methacrylate

CAS No.: 9086-85-5

Cat. No.: B7721401

[Get Quote](#)

Executive Summary & Strategic Rationale

While Poly(ethylene glycol) (PEG) has long been the "gold standard" for stealth hydrogels, N-(2-hydroxypropyl)methacrylamide (HPMA) offers a distinct advantage: multivalent functionalization potential. Unlike PEG, which is limited to chain-end modification, HPMA polymerization allows for the incorporation of functional side chains at every repeat unit.

This guide details the engineering of HPMA hydrogel scaffolds, moving beyond simple encapsulation to bioactive, stimuli-responsive matrices. We focus on two high-value applications: neuro-regenerative cryogels (macroporous scaffolds) and enzyme-responsive drug Depots.

HPMA vs. PEG: The Causality of Choice

Feature	PEG Hydrogels	HPMA Hydrogels	Strategic Advantage of HPMA
Backbone Chemistry	Polyether	Polymethacrylamide	Greater hydrolytic stability of the backbone; side-chains are easily derivatized.
Functionalization	Chain-end only (typically)	Pendant side-chains	High-density ligand attachment (e.g., RGD peptides) without sacrificing crosslinking density.
Immunogenicity	Generally low (some anti-PEG Ab)	Non-immunogenic	Clinical track record in polymer-drug conjugates (e.g., PK1, PK2).
Crosslinking	Acrylate/Thiol-ene	Reactive esters/Amides	Facile "polymer-analogous" crosslinking allows incorporation of sensitive peptides after polymerization.

Core Chemistry & Synthesis Workflows

The synthesis of HPMA hydrogels typically follows one of two routes:

- **Direct Copolymerization:** Monomers and crosslinkers are polymerized simultaneously.
- **Polymer-Analogous Crosslinking:** A reactive copolymer precursor is synthesized first, then crosslinked with a diamine or peptide. This is the preferred method for biomedical applications as it allows for purification of the polymer backbone before gelation and protects sensitive biological crosslinkers from radical stress.

DOT Diagram 1: The Reactive Precursor Synthesis Pathway

This workflow illustrates the "Polymer-Analogous" route, ensuring high fidelity of bioactive ligands.

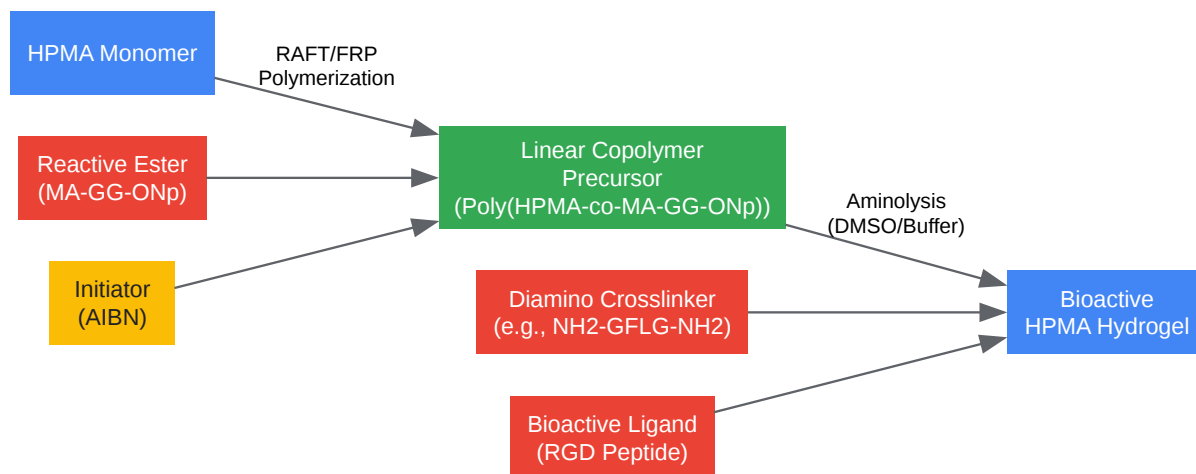

[Click to download full resolution via product page](#)

Caption: Synthesis of HPMA hydrogels via reactive ester precursors allows independent tuning of crosslinking density and ligand concentration.

Protocol 1: Synthesis of Macroporous HPMA Cryogels

Application: Spinal Cord Injury (SCI) Scaffolds, Tissue Engineering. Mechanism: Cryogelation (polymerization at -20°C) forces the polymerizing phase into narrow channels between ice crystals. When the ice melts, it leaves behind a macroporous network (pores 10–100 μm) essential for cell migration and axon extension.

Materials

- Monomer: HPMA (Synthesized in-house or commercial).
- Crosslinker: N,N'-methylenebis(acrylamide) (MBA) or biodegradable peptide crosslinkers.

- Initiator System: Ammonium persulfate (APS) and TEMED.[1]
- Solvent: Deionized water (degassed).[1]

Step-by-Step Methodology

- Monomer Solution Prep:
 - Dissolve HPMA (1.0 g) and MBA (20 mg, ~2 wt%) in degassed water (5.0 mL) to achieve a total monomer concentration of ~20 wt%.
 - Expert Insight: For neural applications, add RGD peptide (1 mg/mL) containing a methacrylamide group (MA-GG-RGD) to the monomer mix to promote cell adhesion.
- Initiation:
 - Cool the solution to 4°C on ice to prevent premature polymerization.
 - Add TEMED (10 µL) and mix.
 - Add APS (100 µL of a 10% w/v solution) and mix rapidly (10 seconds).
- Cryogelation (The Critical Step):
 - Immediately inject the solution into glass molds or syringes (e.g., 1 mL tuberculin syringes with cut tips).
 - Place molds in a cryostat or freezer preset to -18°C.
 - Incubate for 18–24 hours.
 - Why: The slow freezing rate allows large ice crystals to form, which act as porogens.
- Thawing and Washing:
 - Remove molds and thaw at room temperature.
 - Expel the cryogels and wash extensively with water for 48 hours to remove unreacted monomers and initiators.

- Sterilization:
 - Sterilize by autoclaving (HPMA is thermally stable) or UV irradiation before cell seeding.

Validation Check (Self-Correcting)

- Sponge Test: The resulting cryogel should be opaque and sponge-like. It should release water upon compression and re-swell immediately (shape memory). If it is transparent and brittle, cryogelation failed (likely temperature was too low or polymerization too fast).

Protocol 2: Enzyme-Responsive Drug Delivery Hydrogels

Application: Localized Chemotherapy (e.g., Doxorubicin release). Mechanism: The hydrogel is crosslinked via the peptide sequence Gly-Phe-Leu-Gly (GFLG). This sequence is a specific substrate for Cathepsin B, an enzyme overexpressed in tumor microenvironments.

Materials

- Polymer Precursor: Poly(HPMA-co-MA-GG-ONp) (approx. 5 mol% reactive ONp ester groups).
- Crosslinker:
(Diamino-peptide).
- Drug: Doxorubicin-NH₂ (or Dox conjugated to the polymer backbone).

Step-by-Step Methodology

- Precursor Dissolution:
 - Dissolve Poly(HPMA-co-MA-GG-ONp) (100 mg) in dry DMSO (0.5 mL).
- Crosslinking (Aminolysis):
 - Calculate the molar equivalent of ONp groups.
 - Add

(0.5 equivalents relative to ONp groups) dissolved in a minimum amount of DMSO.

- Add Triethylamine (TEA) as a catalyst.
- Gelation:
 - Inject the mixture into a mold. Gelation occurs within 1–4 hours at room temperature as the amine groups react with the ONp esters, displacing p-nitrophenol (solution turns yellow).
- Purification:
 - Remove the gel and wash in acetone (to remove DMSO and p-nitrophenol) followed by hydration in PBS.
 - Note: The yellow color disappearance indicates successful removal of the leaving group.

DOT Diagram 2: Enzyme-Triggered Degradation Mechanism

This diagram visualizes how the hydrogel senses the biological environment to release its payload.

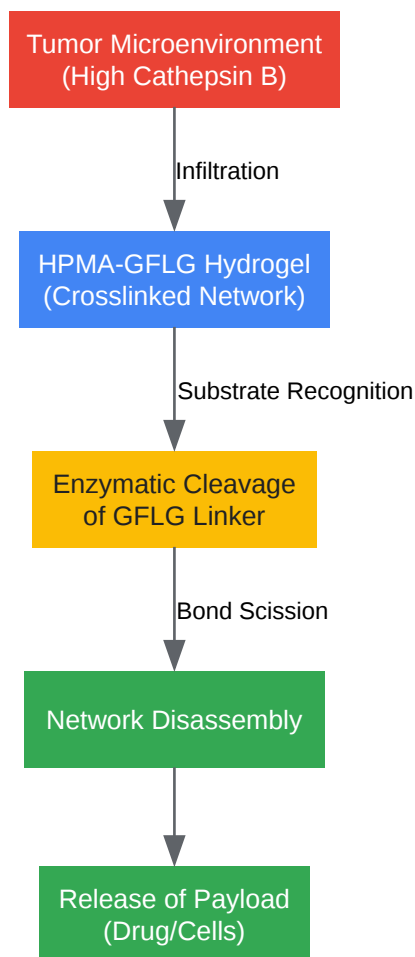

[Click to download full resolution via product page](#)

Caption: Cathepsin B-mediated cleavage of GFLG crosslinks triggers site-specific hydrogel degradation.

Characterization & Quantitative Benchmarks

To validate your HPMA hydrogels, compare your results against these standard ranges.

Table 1: Comparative Properties of HPMA Hydrogel Variants

Property	Standard HPMA (Chemically Crosslinked)	HPMA Cryogel (Macroporous)	HPMA-RGD (Bioactive)
Water Content (EWC)	85 – 95%	> 95%	90 – 95%
Pore Size	2 – 10 nm (Mesh size)	10 – 100 μm	2 – 10 nm
Compressive Modulus	5 – 50 kPa	1 – 10 kPa (Soft, spongy)	5 – 40 kPa
Degradation Profile	Non-degradable (unless biodegradable crosslinker used)	Stable	Tunable (Enzymatic/Hydrolytic)
Cell Adhesion	Negligible (Non-fouling)	Moderate (Physical entrapment)	High (Integrin-mediated)

Key Characterization Assays

- Swelling Ratio ():
 - Weigh dry gel (), equilibrate in PBS for 24h, weigh swollen gel ().
- Rheology: Perform an amplitude sweep to determine the Linear Viscoelastic Region (LVR), followed by a frequency sweep (0.1–10 Hz).
 - Target: Storage modulus () should be $>$ Loss modulus () by at least 1 order of magnitude.

- Porosity (Cryogels): Use Archimedes' principle or Mercury Porosimetry.
 - Quick Check: Squeeze the cryogel under water. It should release bubbles and re-absorb water instantly like a sponge.

Troubleshooting & Optimization

- Issue: Hydrogel is too brittle.
 - Cause: Crosslinking density is too high (>5 mol%).
 - Fix: Reduce crosslinker (MBA or peptide) concentration to 1–2 mol%.
- Issue: No gelation in Cryogel protocol.
 - Cause: "Supercooling" without nucleation or oxygen inhibition.
 - Fix: Increase APS/TEMED concentration slightly or degas the monomer solution more thoroughly (nitrogen purge for 15 min). Ensure the freezer is not colder than -20°C (too fast freezing creates small pores, too slow prevents gelation).
- Issue: Cells not attaching.
 - Cause: HPMA is inherently anti-fouling.
 - Fix: You must incorporate an adhesion ligand (RGD, IKVAV). Verify ligand incorporation using amino acid analysis or UV-Vis (if ligand has a chromophore).

References

- Kopeček, J., & Kopečková, P. (2010). HPMA copolymers: Origins, early developments, present, and future. *Advanced Drug Delivery Reviews*, 62(2), 122-149.
- Woerly, S., et al. (2004). Neural tissue formation within porous hydrogels implanted in brain and spinal cord lesions: Ultrastructural, immunohistochemical, and diffusion studies. *Tissue Engineering*, 10(3-4), 413-432.

- Mauri, E., et al. (2016). The Synthesis of RGD-functionalized Hydrogels as a Tool for Therapeutic Applications. *Journal of Visualized Experiments (JoVE)*, (116), e54445.
- Drury, J. L., & Mooney, D. J. (2003). Hydrogels for tissue engineering: Scaffold design variables and applications. *Biomaterials*, 24(24), 4337-4351.
- BenchChem. (2025).^[1]^[2] Application Notes and Protocols for Creating Crosslinked HPMA Hydrogels. BenchChem Application Notes.

Need Custom Synthesis?

BenchChem offers custom synthesis for rare earth carbides and specific isotopic labeling.

Email: info@benchchem.com or [Request Quote Online](#).

Sources

- 1. pdf.benchchem.com [pdf.benchchem.com]
- 2. [benchchem.com](https://www.benchchem.com) [[benchchem.com](https://www.benchchem.com)]
- To cite this document: BenchChem. [Application Note: HPMA-Based Hydrogel Scaffolds for Biomedical Applications]. BenchChem, [2026]. [Online PDF]. Available at: [<https://www.benchchem.com/product/b7721401/docs#application-note-hpma-based-hydrogel-scaffolds-for-biomedical-applications>]

Disclaimer & Data Validity:

The information provided in this document is for Research Use Only (RUO) and is strictly not intended for diagnostic or therapeutic procedures. While BenchChem strives to provide accurate protocols, we make no warranties, express or implied, regarding the fitness of this product for every specific experimental setup.

Technical Support: The protocols provided are for reference purposes. Unsure if this reagent suits your experiment?

Need Industrial/Bulk Grade? [Request Custom Synthesis Quote](#)

BenchChem

Our mission is to be the trusted global source of essential and advanced chemicals, empowering scientists and researchers to drive progress in science and industry.

Contact

Address: 3281 E Guasti Rd
Ontario, CA 91761, United States
Phone: (601) 213-4426
Email: info@benchchem.com

[Contact our Ph.D. Support Team for a compatibility check](#)