

Application Notes and Protocols for Environmental Resistant Coatings on Molybdenum Silicide Alloys

Author: BenchChem Technical Support Team. **Date:** December 2025

Compound of Interest

Compound Name: *Molybdenum silicide*

Cat. No.: B077889

[Get Quote](#)

For Researchers, Scientists, and Drug Development Professionals

This document provides detailed application notes and protocols for the deposition and evaluation of environmental resistant coatings on **molybdenum silicide** (Mo-Si) alloys. These coatings are critical for protecting the underlying alloy from high-temperature oxidation and other aggressive environments, thereby extending the operational lifetime of components in demanding applications.

Introduction to Environmental Resistant Coatings for Mo-Si Alloys

Molybdenum silicide alloys, particularly those based on MoSi₂, are promising materials for high-temperature structural applications due to their high melting point and excellent mechanical properties. However, they are susceptible to oxidation, especially the catastrophic "pest" oxidation at intermediate temperatures (400-800°C) and volatilization of molybdenum oxides at very high temperatures.[1][2] To mitigate these degradation mechanisms, various environmental resistant coatings have been developed.

The primary protection mechanism of these coatings is the formation of a dense, stable, and self-healing oxide scale, typically silica (SiO₂), on the surface.[3][4][5] This scale acts as a diffusion barrier, preventing oxygen from reaching the underlying alloy.[2][6] Common coating

systems include Mo-Si-B formulations and MoSi₂-based composites modified with ceramics like ZrB₂, Al₂O₃, and mullite to enhance performance.[4][7][8][9][10]

Coating Materials and Application Technologies

Several materials and deposition techniques are employed to create robust protective coatings on Mo-Si alloys. The choice of material and method depends on the specific application requirements, including operating temperature, environment, and component geometry.

Coating Materials:

- **Mo-Si-B Systems:** These coatings form a complex aluminoborosilica surface layer with self-healing characteristics.[7][8] The addition of boron enhances the oxidation resistance of the silicide phases.[11]
- **MoSi₂-Based Composites:**
 - **With Zirconium Diboride (ZrB₂):** The addition of ZrB₂ improves high-temperature performance through the formation of a composite oxide scale of SiO₂, ZrO₂, and ZrSiO₄, which has enhanced thermal stability.[4][12]
 - **With Alumina (Al₂O₃):** Alumina additions help to suppress low-temperature pest oxidation and improve high-temperature resistance by forming a stable SiO₂-mullite composite oxide layer.[9]
 - **With Mullite (3Al₂O₃·2SiO₂):** Mullite is known for its high-temperature strength, creep resistance, and corrosion resistance, making it a suitable reinforcement for MoSi₂-based coatings.[13]
- **Polymer-Derived Ceramics (PDCs):** Preceramic polymers can be used to form dense and adherent silicon oxycarbide (SiOC) or silicon oxynitride (SiNO) coatings with homogeneously distributed filler particles.[3][14][15]

Application Technologies:

- **Pack Cementation:** A chemical vapor deposition process where the component is packed in a powder mixture containing the depositing elements (e.g., Si, B), an activator (e.g., NaF),

and an inert filler (e.g., Al_2O_3).[\[16\]](#)[\[17\]](#)[\[18\]](#) This method is effective for creating diffusion coatings.[\[11\]](#)

- Slurry Coating: A slurry containing the coating powders is applied to the substrate, followed by a high-temperature sintering or diffusion treatment to form the coating.[\[4\]](#)[\[9\]](#)[\[19\]](#)[\[20\]](#)[\[21\]](#)
- Thermal Spraying (Plasma Spray): A versatile process where molten or semi-molten particles of the coating material are sprayed onto the substrate at high velocity.[\[22\]](#)[\[23\]](#)[\[24\]](#)[\[25\]](#) It is suitable for a wide range of materials, including refractory metals and ceramics.[\[26\]](#)[\[23\]](#)
- Electrophoretic Deposition (EPD): A method where charged particles in a colloidal suspension are deposited onto a conductive substrate under an electric field.[\[27\]](#)[\[28\]](#)[\[29\]](#)

Quantitative Data on Coating Performance

The following tables summarize key performance data for various environmental resistant coatings on Mo-Si alloys.

Coating System	Substrate	Application Method	Coating Thickness (μm)	Max. Operating Temperature ($^{\circ}\text{C}$)	Protection Duration	Key Findings
Mo-Si-B	Mo-3Si-1B	Pack Cementation	~10	1400	>100 hours	Forms a protective borosilica glass layer. [11]
MoSi ₂ -ZrB ₂	TZM Alloy	Slurry Sintering + Pack Siliconizing	Not specified	1600	20 hours	Weight gain of only 5.24 mg/cm ² . [4]
(Mo,Hf)Si ₂ -Al ₂ O ₃	Mo-La ₂ O ₃ Alloy	Slurry Sintering	Not specified	1400	40 hours	Mass gain of 6.03 mg/cm ² . [9]
WSi ₂ -Mullite-MoSi ₂	Siliconized Nb Alloy	Atmospheric Plasma Spraying	Not specified	1500	≥500 hours	Mass loss of 4.41 mg/cm ² . [10]
MoSi ₂	TZM Alloy	Slurry Coating	~65	1000	Stable with negligible mass gain. [20]	

Experimental Protocols

This section provides detailed protocols for the application and testing of environmental resistant coatings.

Protocol for Pack Cementation of a Mo-Si-B Coating

Objective: To deposit a Mo-Si-B diffusion coating on a **molybdenum silicide** alloy substrate.

Materials:

- **Molybdenum silicide** alloy substrate
- Pack powder mixture:
 - Silicon (Si) powder (donor)
 - Boron (B) powder or Boride compound (e.g., TiB_2) (donor)[17]
 - Sodium Fluoride (NaF) powder (activator)[17]
 - Alumina (Al_2O_3) powder (inert filler)[16][17]
- Alumina crucible with a lid
- High-temperature tube furnace with argon gas supply
- Silica sol for sealing[16]

Procedure:

- Substrate Preparation: a. Mechanically polish the substrate to a mirror-like finish. b. Ultrasonically clean the substrate in an acetone bath for 20 minutes and dry completely.[16]
- Pack Mixture Preparation: a. Prepare the powder mixture with the desired weight percentages (e.g., 8 wt.% Si, 8 wt.% TiB_2 , 5 wt.% NaF, 79 wt.% Al_2O_3).[17] b. Homogenize the powders in a planetary ball mill for 4 hours.[16]
- Pack Cementation Process: a. Place the substrate inside the alumina crucible and completely cover it with the prepared pack mixture. b. Seal the crucible with a lid and apply a silica sol to ensure an airtight seal.[16] c. Place the sealed crucible in the tube furnace. d. Purge the furnace with argon gas. e. Heat the furnace to the desired deposition temperature (e.g., 1000-1300°C) at a controlled rate (e.g., 5°C/min).[17] f. Hold at the deposition temperature for the specified duration (e.g., 5-10 hours).[16][17] g. Cool the furnace down to room temperature.

- Post-Coating Cleaning: a. Carefully remove the coated substrate from the crucible. b. Clean off any remaining powder from the surface.

Protocol for Slurry Coating of a MoSi₂-Based Composite

Objective: To apply a MoSi₂-based composite coating (e.g., with ZrB₂ additions) onto a Mo-based alloy.

Materials:

- Mo-based alloy substrate (e.g., TZM)
- Coating slurry components:
 - Molybdenum (Mo) powder
 - Zirconium (Zr) powder
 - Boron Carbide (B₄C) powder
 - Ethyl acetate (solvent)
 - Nitrocellulose (binder)
- Attrition mill
- Spray gun
- Vacuum furnace

Procedure:

- Substrate Preparation: a. Cut the substrate to the desired dimensions. b. Polish the substrate surfaces with SiC paper and then ultrasonically clean in ethanol.
- Slurry Preparation: a. Prepare a Mo slurry by mixing Mo powder with ethyl acetate and a small amount of nitrocellulose binder. Attrition mill for 6 hours.^[4] b. Prepare a Zr-B₄C slurry by mixing Zr and B₄C powders (e.g., 1:1 molar ratio) with ethyl acetate and nitrocellulose. Attrition mill for 6 hours.^[4]

- Slurry Application: a. Spray the Mo slurry evenly onto the substrate surface.[4] b. Subsequently, spray the Zr-B₄C slurry over the Mo layer.
- Sintering: a. Place the coated substrate in a vacuum furnace. b. Heat to a high temperature (e.g., 1700°C) and hold for a specified time (e.g., 2 hours) in a vacuum (<1 Pa) to form a ceramic pre-layer.[4]
- Siliconizing (Pack Cementation): a. Prepare a pack mixture containing Si powder, Al₂O₃ inert filler, and NaF activator (e.g., 67:30:3 mass ratio).[4] b. Embed the sintered sample in the pack mixture within an alumina crucible. c. Heat in an argon-protected tube furnace to a temperature such as 1150°C and hold for 10 hours.[4] d. Furnace cool to room temperature.

Protocol for High-Temperature Oxidation Testing

Objective: To evaluate the oxidation resistance of the coated samples at elevated temperatures.

Materials:

- Coated sample
- High-temperature furnace capable of reaching the desired test temperature in an air atmosphere.
- Alumina sample holder
- High-precision analytical balance

Procedure:

- Initial Measurement: a. Measure the initial dimensions of the coated sample. b. Weigh the sample accurately using the analytical balance.
- Isothermal Oxidation Test: a. Place the sample in the alumina holder and insert it into the furnace. b. Heat the furnace to the desired oxidation temperature (e.g., 1400-1600°C) in static air.[4][9] c. Hold the sample at the test temperature for a predetermined duration (e.g., 1, 5, 10, 20, 40 hours).[4][9]

- Weight Change Measurement: a. After each time interval, remove the sample from the furnace and allow it to cool to room temperature. b. Weigh the oxidized sample. c. Calculate the weight change per unit surface area (mg/cm^2).
- Cyclic Oxidation Test (Optional): a. Heat the sample to the test temperature for a set period (e.g., 1 hour). b. Cool the sample to room temperature. c. Repeat the cycle for a specified number of cycles. d. Measure the weight change after each cycle.
- Characterization: a. Analyze the surface and cross-section of the oxidized samples using Scanning Electron Microscopy (SEM) and Energy Dispersive X-ray Spectroscopy (EDS) to examine the oxide scale morphology and composition. b. Use X-ray Diffraction (XRD) to identify the phases present in the coating and the oxide scale.

Visualizations

The following diagrams illustrate key processes and concepts related to environmental resistant coatings on **molybdenum silicide** alloys.

Workflow for Pack Cementation Coating

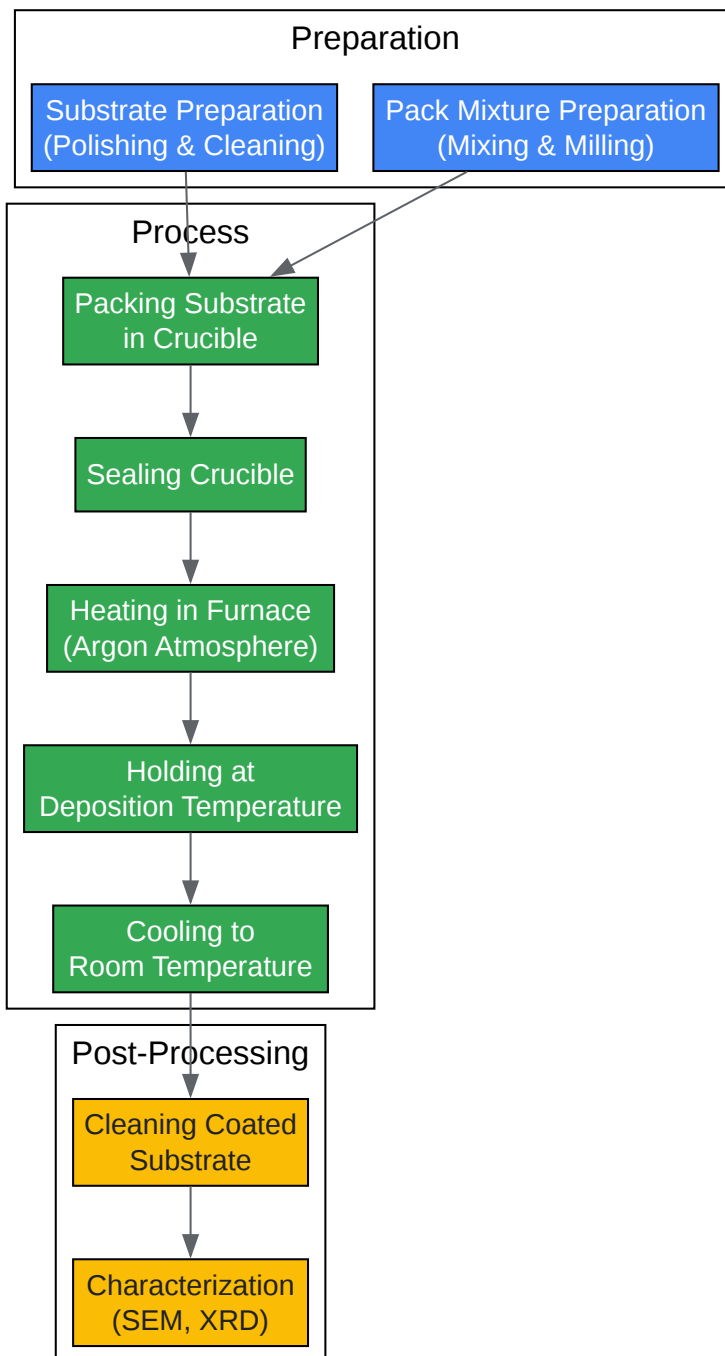

[Click to download full resolution via product page](#)

Caption: A flowchart of the pack cementation process.

Protective Mechanism of a Multi-Layer Mo-Si-B Coating

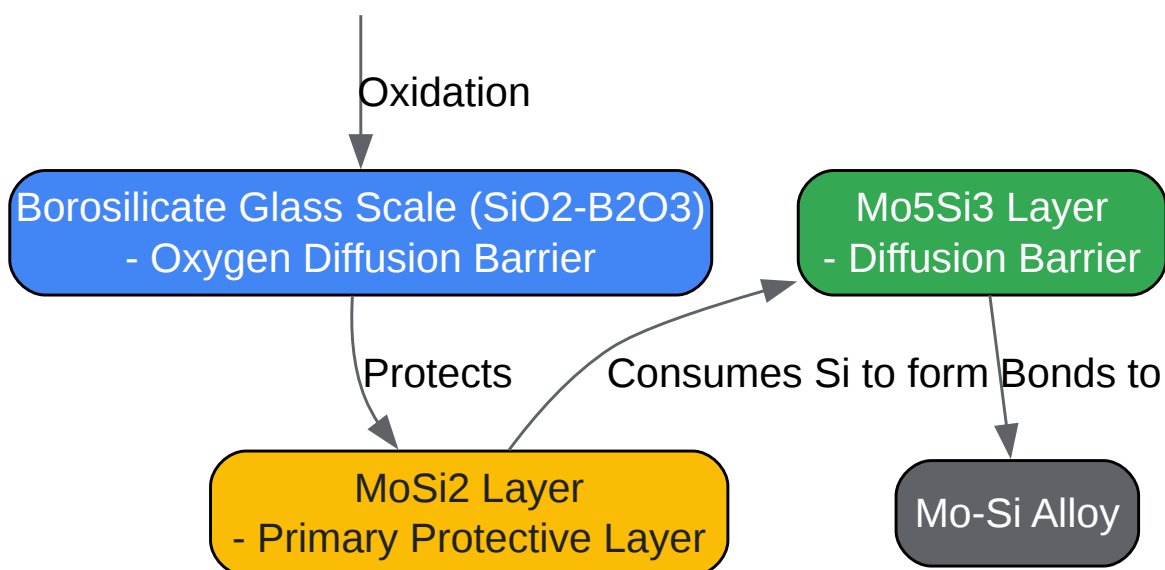

[Click to download full resolution via product page](#)

Caption: Protective layers of a Mo-Si-B coating system.

Workflow for Slurry Coating and Sintering

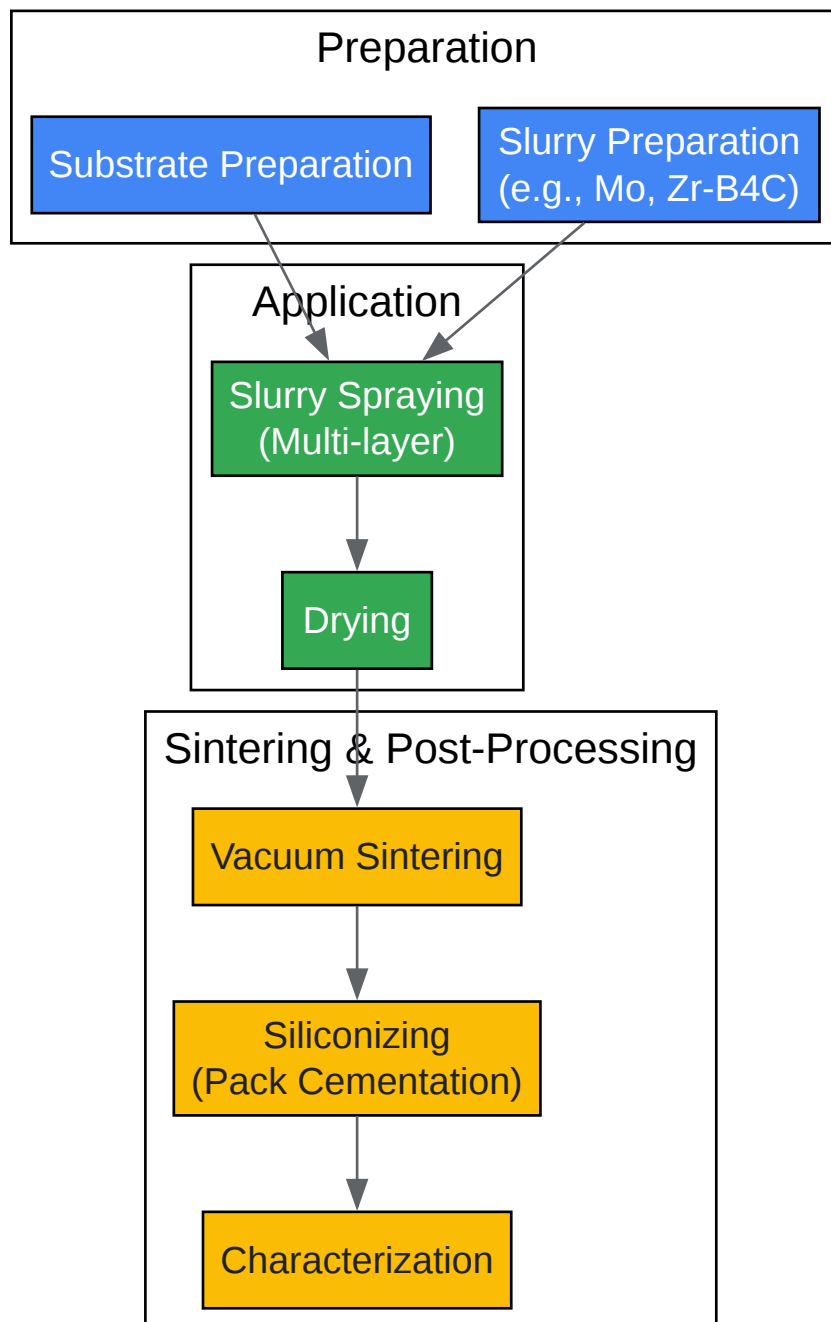

[Click to download full resolution via product page](#)

Need Custom Synthesis?

BenchChem offers custom synthesis for rare earth carbides and specific isotopic labeling.

Email: info@benchchem.com or [Request Quote Online](#).

References

- 1. [mdpi.com](#) [[mdpi.com](#)]
- 2. [ntrs.nasa.gov](#) [[ntrs.nasa.gov](#)]
- 3. [researchgate.net](#) [[researchgate.net](#)]
- 4. [mdpi.com](#) [[mdpi.com](#)]
- 5. [researchgate.net](#) [[researchgate.net](#)]
- 6. [researchgate.net](#) [[researchgate.net](#)]
- 7. Environmental Resistant Coatings for High Temperature Mo and Nb Silicide Alloys | MRS Advances | Cambridge Core [[cambridge.org](#)]
- 8. [researchgate.net](#) [[researchgate.net](#)]
- 9. [mdpi.com](#) [[mdpi.com](#)]
- 10. [researchgate.net](#) [[researchgate.net](#)]
- 11. [apps.dtic.mil](#) [[apps.dtic.mil](#)]
- 12. [kygczz.com](#) [[kygczz.com](#)]
- 13. [apps.dtic.mil](#) [[apps.dtic.mil](#)]
- 14. [researchgate.net](#) [[researchgate.net](#)]
- 15. Formation of Protective Coatings on TZM Molybdenum Alloy by Complex Aluminosiliconizing and Application of a Pre-ceramic Layer [[mdpi.com](#)]
- 16. Frontiers | High-Performance Al–Si Coatings Toward Enhancing Oxidation Resistance of Tungsten by Halide-Activated Pack Cementation [[frontiersin.org](#)]
- 17. [mdpi.com](#) [[mdpi.com](#)]
- 18. [researchgate.net](#) [[researchgate.net](#)]
- 19. [mdpi.com](#) [[mdpi.com](#)]
- 20. [researchgate.net](#) [[researchgate.net](#)]
- 21. [researchgate.net](#) [[researchgate.net](#)]
- 22. Plasma Spray Coating | MBL Metallic Bonds LTD United States [[metallicbonds.com](#)]
- 23. [bodycote.com](#) [[bodycote.com](#)]
- 24. Thermal spraying - Wikipedia [[en.wikipedia.org](#)]
- 25. [m.youtube.com](#) [[m.youtube.com](#)]

- 26. Plasma Spray - Lincotek [lincotek.com]
- 27. Electrophoretic deposition of chitosan coatings on the Ti15Mo biomedical alloy from a citric acid solution - PMC [pmc.ncbi.nlm.nih.gov]
- 28. mdpi.com [mdpi.com]
- 29. researchgate.net [researchgate.net]
- To cite this document: BenchChem. [Application Notes and Protocols for Environmental Resistant Coatings on Molybdenum Silicide Alloys]. BenchChem, [2025]. [Online PDF]. Available at: [<https://www.benchchem.com/product/b077889#environmental-resistant-coatings-for-mo-silicide-alloys>]

Disclaimer & Data Validity:

The information provided in this document is for Research Use Only (RUO) and is strictly not intended for diagnostic or therapeutic procedures. While BenchChem strives to provide accurate protocols, we make no warranties, express or implied, regarding the fitness of this product for every specific experimental setup.

Technical Support: The protocols provided are for reference purposes. Unsure if this reagent suits your experiment? [[Contact our Ph.D. Support Team for a compatibility check](#)]

Need Industrial/Bulk Grade? [Request Custom Synthesis Quote](#)

BenchChem

Our mission is to be the trusted global source of essential and advanced chemicals, empowering scientists and researchers to drive progress in science and industry.

Contact

Address: 3281 E Guasti Rd

Ontario, CA 91761, United States

Phone: (601) 213-4426

Email: info@benchchem.com