

# Application Notes & Protocols: Leveraging Sodium Sulphonatopalmitate in Advanced Sol-Gel Synthesis

**Author:** BenchChem Technical Support Team. **Date:** April 2026

## Compound of Interest

Compound Name:	Sodium hydrogen sulphonatopalmitate
CAS No.:	10538-20-2
Cat. No.:	B077898

[Get Quote](#)

## Introduction: Bridging Functional Surfactants and Sol-Gel Chemistry

The sol-gel process represents a cornerstone of modern materials science, offering a versatile wet-chemical route to produce glassy and ceramic materials with exceptional control over their final properties.[1][2] This process involves the transition of a colloidal solution (sol) into an integrated, porous network (gel).[3][4] A key advantage of sol-gel synthesis is the ability to incorporate organic molecules to create functionalized hybrid materials.[5][6]

Surfactants, or surface-active agents, are a class of molecules that have become indispensable in sol-gel chemistry. They act as templating agents, self-assembling into micelles that guide the formation of porous structures within the inorganic network, a technique often referred to as "direct templating." [7][8] This allows for precise control over pore size, distribution, and overall material morphology.[9]

This guide focuses on the application of a unique functional surfactant, sodium sulphonatopalmitate, in sol-gel processing.

A Note on Nomenclature: The term "**sodium hydrogen sulphonatopalmitate**" is not standard. Based on its constituent parts, this guide will interpret the compound as an  $\alpha$ -sulfonated palmitic acid sodium salt. This is an anionic surfactant with a 16-carbon aliphatic tail and two polar head groups: a carboxylate and a sulfonate. This dual-functionality makes it a compelling candidate for advanced sol-gel applications. The synthesis of such compounds can be achieved by reacting palmitic acid with sulfonating agents like sulfur trioxide or chlorosulfonic acid.[\[10\]](#)[\[11\]](#)

The integration of this anionic surfactant into sol-gel synthesis opens pathways to creating materials with not only controlled mesoporosity but also inherent surface functionality, specifically acidic sites from the sulfonate groups.[\[12\]](#) Such materials are highly sought after for applications in catalysis, drug delivery, and advanced separation technologies.[\[13\]](#)

## Core Concepts: The Anionic Surfactant Templating Pathway

The use of anionic surfactants as templates in sol-gel synthesis, particularly for silica, is a sophisticated approach that requires careful control of electrostatic interactions.[\[14\]](#) Unlike the more common cationic surfactant templating, this pathway relies on mediating the interaction between the negatively charged surfactant headgroup and the silica precursors.

This is typically achieved by introducing a co-structure-directing agent (CSDA), such as an aminosilane. The CSDA serves two purposes:

- Its alkoxy silane end co-condenses with the primary silica source (e.g., tetraethyl orthosilicate, TEOS), incorporating it into the inorganic framework.
- Its amine group, which is protonated (positively charged) under synthesis conditions, electrostatically interacts with the anionic headgroup of the sodium sulphonatopalmitate.[\[15\]](#)

This cooperative self-assembly process between the inorganic precursors and the surfactant micelles dictates the final architecture of the material.

Below is a diagram illustrating the proposed mechanism for templating a sol-gel matrix using sodium sulphonatopalmitate and a CSDA.

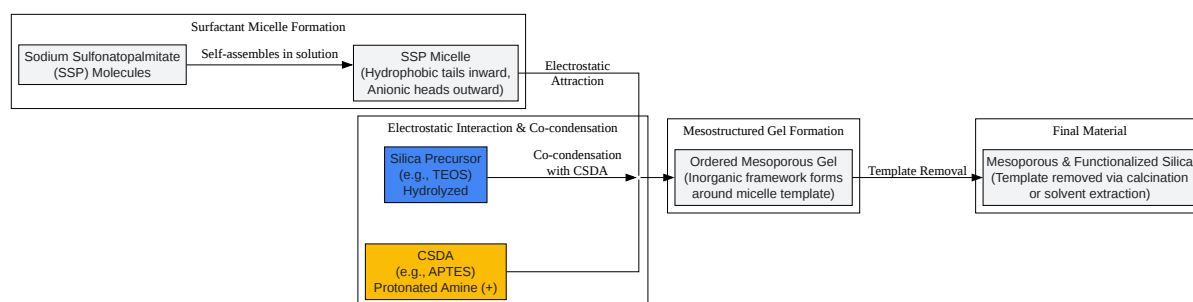

[Click to download full resolution via product page](#)

Caption: Workflow of anionic surfactant templated sol-gel synthesis.

## Experimental Protocols

### Protocol 1: Synthesis of Mesoporous Silica (AMS) using Sodium Sulphonatopalmitate

This protocol details the synthesis of Anionic-surfactant-templated Mesoporous Silica (AMS) with a 2D hexagonal structure.

#### Materials and Reagents

Reagent	Formula	Purity	Supplier
Sodium $\alpha$ -Sulfonatopalmitate	$C_{16}H_{31}NaO_5S$	98%	(Specify Source)
(3-Aminopropyl)triethoxy silane (APTES)	$C_9H_{23}NO_3Si$	99%	(Specify Source)
Tetraethyl Orthosilicate (TEOS)	$Si(OC_2H_5)_4$	99%	(Specify Source)
Hydrochloric Acid (HCl)	HCl	37%	(Specify Source)
Deionized Water	$H_2O$	>18 M $\Omega$	(Specify Source)
Ethanol	$C_2H_5OH$	99.5%	(Specify Source)

### Step-by-Step Methodology

- Template Solution Preparation:
  - In a polypropylene beaker, dissolve 1.0 g of sodium  $\alpha$ -sulfonatopalmitate in 50 mL of deionized water.
  - Add 20 mL of ethanol and stir until the solution is clear. This forms the surfactant template solution.
  - Rationale: Ethanol acts as a co-solvent to improve the solubility of the surfactant and facilitate mixing with the silica precursor.
- Precursor & CSDA Addition:
  - To the stirring template solution, add 0.75 g of APTES (the CSDA). Stir for 30 minutes.
  - Slowly add 4.25 g of TEOS (the silica source) to the mixture.
  - Rationale: APTES is added first to allow for its interaction with the surfactant micelles before the bulk of the silica network begins to form.

- pH Adjustment & Gelation:
  - Adjust the pH of the solution to ~5.0 by dropwise addition of 1 M HCl.
  - Cover the beaker and continue stirring at 40°C for 2 hours.
  - Transfer the sealed container to an oven and age at 100°C for 48 hours without stirring. A solid white precipitate will form.
  - Rationale: The sol-gel process is highly pH-dependent.[16] Mildly acidic conditions control the hydrolysis and condensation rates of TEOS, allowing for an ordered structure to form. Aging at elevated temperature promotes the polymerization and strengthening of the silica network.[4]
- Product Recovery and Washing:
  - Cool the container to room temperature. Filter the white solid and wash it thoroughly with deionized water until the washings are neutral.
  - Wash again with ethanol to remove residual water.
  - Dry the powder at 60°C overnight. The resulting material is the as-synthesized mesoporous silica containing the template.
- Template Removal (Calcination):
  - Place the dried powder in a ceramic crucible.
  - Heat in a muffle furnace under a slow air flow. Ramp the temperature at 1°C/min to 550°C and hold for 6 hours.
  - Cool the furnace slowly to room temperature. The resulting white powder is the final mesoporous silica.
  - Rationale: Calcination burns away the organic template (surfactant and CSDA), leaving behind the porous inorganic structure. The slow ramp rate prevents cracking of the material.

The logical relationship between the key synthesis steps is visualized below.

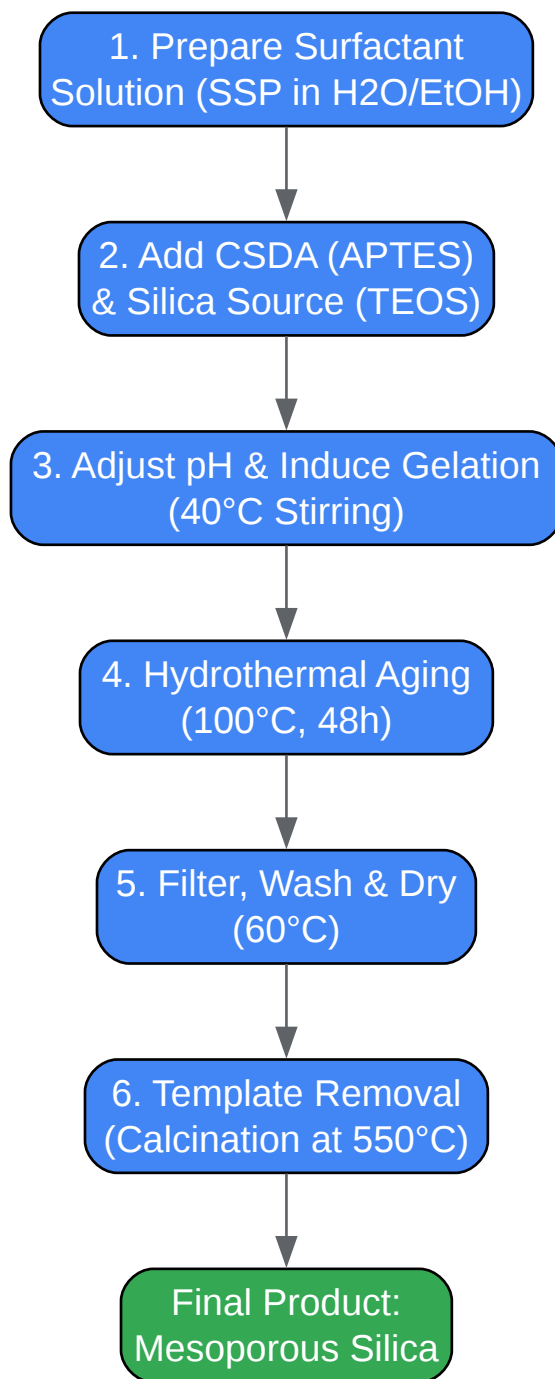

[Click to download full resolution via product page](#)

Caption: Key stages in the synthesis of mesoporous silica.

## Protocol 2: In-Situ Functionalization of a Sol-Gel Matrix

This protocol aims to create a sol-gel material where the sulfonate group from the surfactant is retained, imparting acidic properties to the final material. This is achieved by using a milder solvent extraction for template removal.

### Methodology

- Synthesis: Follow steps 1-4 from Protocol 1 to obtain the as-synthesized, template-containing material.
- Template Removal (Solvent Extraction):
  - Disperse 1.0 g of the dried, as-synthesized powder in 100 mL of ethanol containing 0.1 M HCl.
  - Reflux the mixture at 80°C for 6 hours with vigorous stirring.
  - Filter the solid and repeat the extraction process two more times with fresh ethanol/HCl solution.
  - Rationale: The acidified ethanol disrupts the electrostatic interaction between the protonated amine of the CSDA and the anionic surfactant, allowing the bulk of the long-chain palmitate to be washed away while potentially leaving some sulfonate groups anchored via the CSDA.
- Final Washing and Drying:
  - Wash the extracted powder thoroughly with pure ethanol to remove all traces of HCl.
  - Dry the final product in a vacuum oven at 80°C for 12 hours.

## Characterization and Analysis

The synthesized materials should be characterized to confirm their structure, porosity, and functionality.

Technique	Information Provided
Transmission Electron Microscopy (TEM)	Visualization of the ordered pore structure and measurement of pore diameter.
Nitrogen Adsorption-Desorption	Determination of BET surface area, pore volume, and pore size distribution.
Small-Angle X-ray Scattering (SAXS)	Confirmation of the mesostructure (e.g., hexagonal, cubic) and unit cell parameters.
Fourier-Transform Infrared (FTIR) Spectroscopy	Confirmation of Si-O-Si network formation and successful removal of the organic template. For Protocol 2, look for characteristic S=O stretching peaks to verify sulfonate group retention.
Thermogravimetric Analysis (TGA)	Quantifies the amount of organic template present and determines the appropriate calcination temperature.

## Troubleshooting Guide

Problem	Potential Cause	Suggested Solution
No solid product forms after aging	Incorrect pH; insufficient aging time/temperature; incorrect precursor ratios.	Verify pH is ~5.0. Increase aging time or temperature. Re-verify molar ratios of reagents.
Broad or no ordered pore structure	Hydrolysis/condensation rate too fast; poor surfactant-CSDA interaction.	Decrease the reaction temperature during gelation. Ensure thorough mixing after CSDA addition before adding TEOS.
Cracked material after calcination	Ramp rate too fast.	Decrease the heating ramp rate to 1°C/min or slower.
Low surface area	Collapse of the pore structure during drying or calcination.	Consider supercritical drying as an alternative to evaporative drying. Ensure the calcination temperature is not excessive.

## Conclusion and Future Outlook

The use of sodium sulphonatopalmitate as a functional anionic surfactant in sol-gel synthesis offers a promising route to novel materials. This approach combines the pore-directing capabilities of long-chain surfactants with the potential for in-situ functionalization of the material with acidic sulfonate groups. The protocols provided here serve as a robust starting point for researchers to explore these systems. Future work could involve tuning the pore sizes by varying the surfactant concentration, exploring different CSDA molecules to modulate the surface chemistry, and applying these functionalized materials in catalytic esterification reactions or as selective adsorbents in separation processes. The versatility of the sol-gel process, combined with the unique properties of functional surfactants, ensures that this will remain a fertile area for materials innovation.<sup>[5][17]</sup>

## References

- Functional Sol-Gel Composites: Preparation and Applications. National Center for Biotechnology Information. [\[Link\]](#)

- Sol-gel process. Wikipedia. [\[Link\]](#)
- The Sol-Gel Manufacturing Process. MO SCI. [\[Link\]](#)
- $\alpha$ -SULFOPALMITIC ACID. Organic Syntheses. [\[Link\]](#)
- Sol-gel process: an outstanding technology for coatings. ResearchGate. [\[Link\]](#)
- Key Steps in the Sol-Gel Process for Nanoparticle Synthesis. AZoNano. [\[Link\]](#)
- A Surfactant Role on The Polyethylene Glycol (PEG) Nanoparticles by Sol-Gel Method. AIJR Proceedings. [\[Link\]](#)
- Functionalized Sol-Gel Coatings for Optical Applications. Accounts of Chemical Research. [\[Link\]](#)
- Role of a novel cationic gemini surfactant (CGS) on a one-step sol-gel process and photocatalytic properties of TiO<sub>2</sub> powders. IWA Publishing. [\[Link\]](#)
- Sol-gel process – Knowledge and References. Taylor & Francis Online. [\[Link\]](#)
- Functionalized nanoporous architectures derived from sol-gel processes for advanced biomedical applications. Journal of Materials Chemistry B. [\[Link\]](#)
- Functionalized nanoporous architectures derived from sol-gel processes for advanced biomedical applications. Journal of Materials Chemistry B. [\[Link\]](#)
- Synthesis and Properties of Palmitic Acid-2-Hydroxy-3-Sulfonic Sodium Propyl Ester. Scientific.Net. [\[Link\]](#)
- Influence of surfactant on sol-gel-prepared TiO<sub>2</sub>: characterization and photocatalytic dye degradation in water. Frontiers. [\[Link\]](#)
- A novel anionic surfactant templating route for synthesizing mesoporous silica with unique structure. PubMed. [\[Link\]](#)
- A novel anionic surfactant templating route for synthesizing mesoporous silica with unique structure. Semantic Scholar. [\[Link\]](#)

- What are the main functions of the surfactants in sol-gel process for ceramics powder preparation? ResearchGate. [[Link](#)]
- Role of Surfactants in Nanotechnology and Their Applications. ResearchGate. [[Link](#)]
- Formation mechanism of anionic- surfactant-templated mesoporous silica (AMS). DiVA portal. [[Link](#)]
- Studies of anionic surfactant templated mesoporous structures by electron microscopy. Lund University. [[Link](#)]
- Perspective Chapter: Functional Sol–Gel Based Coatings for Innovative and Sustainable Applications. ResearchGate. [[Link](#)]
- Production of sulfonic acids of aliphatic and hydroaromatic carboxylic acids.
- Preparation of sulfonated fatty acid ester surface-active agents.
- Electrochemically Induced Templated Sol-gel Deposition of Mesoporous Silica and Nanocomposites: The New Kid on the ECiD Block. Lirias. [[Link](#)]

### *Need Custom Synthesis?*

*BenchChem offers custom synthesis for rare earth carbides and specific isotopic labeling.*

*Email: [info@benchchem.com](mailto:info@benchchem.com) or [Request Quote Online](#).*

## Sources

- [1. Sol–gel process - Wikipedia \[en.wikipedia.org\]](#)
- [2. vb.nweurope.eu \[vb.nweurope.eu\]](#)
- [3. The Sol-Gel Manufacturing Process – MO SCI \[mo-sci.com\]](#)
- [4. azonano.com \[azonano.com\]](#)
- [5. Functional Sol-Gel Composites: Preparation and Applications - PMC \[pmc.ncbi.nlm.nih.gov\]](#)
- [6. pubs.acs.org \[pubs.acs.org\]](#)
- [7. proceedings.aijr.org \[proceedings.aijr.org\]](#)

- [8. researchgate.net \[researchgate.net\]](#)
- [9. Frontiers | Influence of surfactant on sol-gel-prepared TiO<sub>2</sub>: characterization and photocatalytic dye degradation in water \[frontiersin.org\]](#)
- [10. Organic Syntheses Procedure \[orgsyn.org\]](#)
- [11. US1926442A - Production of sulfonic acids of aliphatic and hydroaromatic carboxylic acids - Google Patents \[patents.google.com\]](#)
- [12. diva-portal.org \[diva-portal.org\]](#)
- [13. Functionalized nanoporous architectures derived from sol–gel processes for advanced biomedical applications - Journal of Materials Chemistry B \(RSC Publishing\) DOI:10.1039/D5TB00958H \[pubs.rsc.org\]](#)
- [14. A novel anionic surfactant templating route for synthesizing mesoporous silica with unique structure - PubMed \[pubmed.ncbi.nlm.nih.gov\]](#)
- [15. semanticscholar.org \[semanticscholar.org\]](#)
- [16. liris.kuleuven.be \[liris.kuleuven.be\]](#)
- [17. researchgate.net \[researchgate.net\]](#)
- [To cite this document: BenchChem. \[Application Notes & Protocols: Leveraging Sodium Sulfonatopalmitate in Advanced Sol-Gel Synthesis\]. BenchChem, \[2026\]. \[Online PDF\]. Available at: \[https://www.benchchem.com/product/b077898/docs#application-notes-protocols-leveraging-sodium-sulfonatopalmitate-in-advanced-sol-gel-synthesis\]](#)

---

### Disclaimer & Data Validity:

The information provided in this document is for Research Use Only (RUO) and is strictly not intended for diagnostic or therapeutic procedures. While BenchChem strives to provide accurate protocols, we make no warranties, express or implied, regarding the fitness of this product for every specific experimental setup.

**Technical Support:** The protocols provided are for reference purposes. Unsure if this reagent suits your experiment?

**Need Industrial/Bulk Grade?** [Request Custom Synthesis Quote](#)

# BenchChem

Our mission is to be the trusted global source of essential and advanced chemicals, empowering scientists and researchers to drive progress in science and industry.

## Contact

Address: 3281 E Guasti Rd

Ontario, CA 91761, United States

Phone: (601) 213-4426

Email: [info@benchchem.com](mailto:info@benchchem.com)

[Contact our Ph.D. Support Team for a compatibility check](#)