

2,6-Dimethyl-4-nitrosophenol reaction mechanisms

Author: BenchChem Technical Support Team. **Date:** January 2026

Compound of Interest

Compound Name: 2,6-Dimethyl-4-nitrosophenol

Cat. No.: B077472

[Get Quote](#)

An In-depth Technical Guide to the Reaction Mechanisms of **2,6-Dimethyl-4-nitrosophenol**

For Researchers, Scientists, and Drug Development Professionals

Introduction

2,6-Dimethyl-4-nitrosophenol is a significant chemical intermediate used in the synthesis of dyes, photographic materials, and pharmaceuticals. Its chemical behavior is characterized by the interplay of its phenolic hydroxyl group, the reactive nitroso group, and the steric influence of the two methyl groups at the ortho positions.[1] A key feature of this compound is its existence in a tautomeric equilibrium with its quinone monoxime isomer, 4-(hydroxyimino)-2,6-dimethylcyclohexa-2,5-dienone.[2] This guide provides a detailed examination of its core reaction mechanisms, supported by experimental protocols and quantitative data.

Synthesis: Electrophilic Nitrosation

The most established method for synthesizing **2,6-Dimethyl-4-nitrosophenol** is through the direct electrophilic nitrosation of 2,6-dimethylphenol.[1]

Reaction Mechanism

The reaction proceeds via an electrophilic aromatic substitution mechanism. First, sodium nitrite reacts with an acid (e.g., sulfuric or hydrochloric acid) in situ to form nitrous acid (HNO₂). The nitrous acid is then protonated and loses water to generate the highly electrophilic nitrosonium ion (NO⁺). The electron-rich ring of 2,6-dimethylphenol then attacks the

nitrosonium ion, followed by deprotonation to restore aromaticity and yield the final product.^[1]

The methyl groups direct the substitution to the para position.

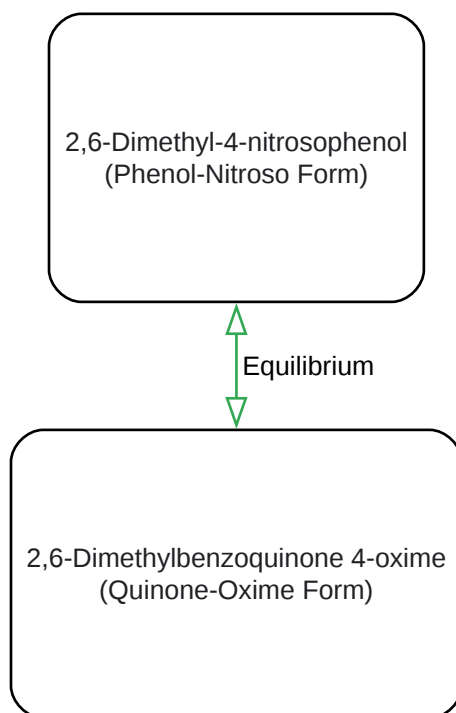
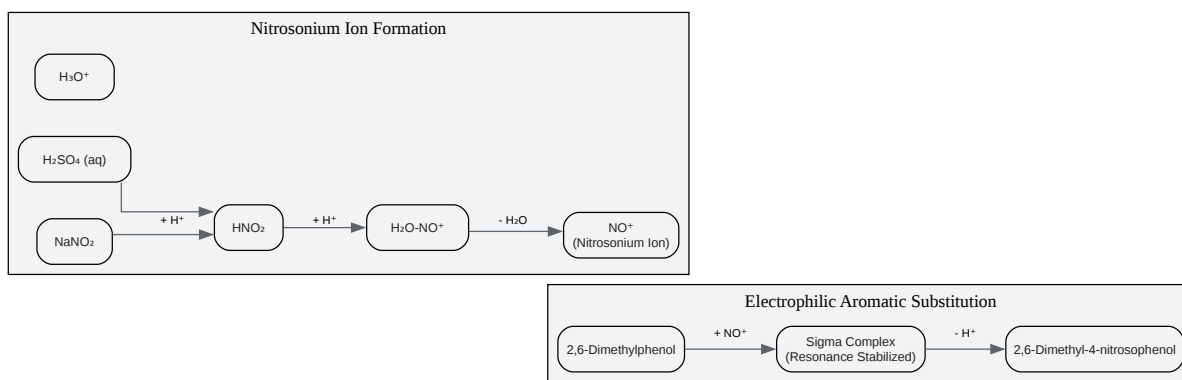

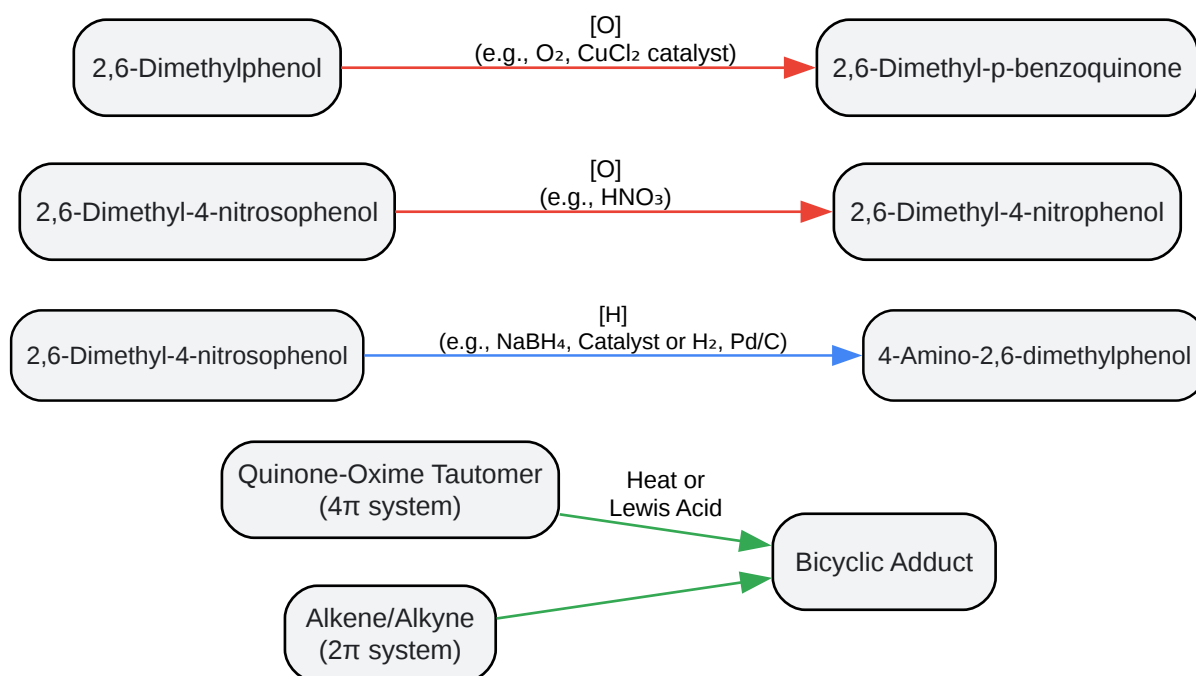

[Click to download full resolution via product page](#)

Need Custom Synthesis?

BenchChem offers custom synthesis for rare earth carbides and specific isotopic labeling.

Email: info@benchchem.com or [Request Quote Online](#).

References

- 1. 2,6-Dimethyl-4-nitrosophenol | 4965-29-1 | Benchchem [benchchem.com]
- 2. 2,6-Dimethyl-4-nitrosophenol | C₈H₉NO₂ | CID 83351 - PubChem [pubchem.ncbi.nlm.nih.gov]
- To cite this document: BenchChem. [2,6-Dimethyl-4-nitrosophenol reaction mechanisms]. BenchChem, [2026]. [Online PDF]. Available at: [https://www.benchchem.com/product/b077472#2-6-dimethyl-4-nitrosophenol-reaction-mechanisms]

Disclaimer & Data Validity:

The information provided in this document is for Research Use Only (RUO) and is strictly not intended for diagnostic or therapeutic procedures. While BenchChem strives to provide accurate protocols, we make no warranties, express or implied, regarding the fitness of this product for every specific experimental setup.

Technical Support: The protocols provided are for reference purposes. Unsure if this reagent suits your experiment? [[Contact our Ph.D. Support Team for a compatibility check](#)]

Need Industrial/Bulk Grade? [Request Custom Synthesis Quote](#)

BenchChem

Our mission is to be the trusted global source of essential and advanced chemicals, empowering scientists and researchers to drive progress in science and industry.

Contact

Address: 3281 E Guasti Rd
Ontario, CA 91761, United States
Phone: (601) 213-4426
Email: info@benchchem.com