

Technical Support Center: Stabilizing 4,6-Dimethyl-2-benzopyrone

Author: BenchChem Technical Support Team. **Date:** April 2026

Compound of Interest

Compound Name: 4,6-Dimethyl-2-benzopyrone

CAS No.: 14002-89-2

Cat. No.: B076538

[Get Quote](#)

This technical support center provides researchers, scientists, and drug development professionals with comprehensive guidance on the long-term storage and stability of **4,6-dimethyl-2-benzopyrone**. Below you will find troubleshooting guides, frequently asked questions (FAQs), and detailed experimental protocols to ensure the integrity of your samples.

Troubleshooting Guide

This guide addresses specific issues that may arise during the handling and storage of **4,6-dimethyl-2-benzopyrone**, helping you to identify and resolve potential stability problems.

Issue	Possible Cause	Recommended Solution
Discoloration of solid sample (e.g., yellowing)	Photodegradation due to exposure to UV or visible light.	Store the compound in an amber vial or a light-blocking container. Work with the compound under low-light conditions or use filtered light.
Oxidation from exposure to air.	Store the compound under an inert atmosphere (e.g., nitrogen or argon). Ensure the container is tightly sealed.	
Changes in chromatographic profile (new peaks, reduced main peak)	Chemical degradation (hydrolysis, oxidation, or photodegradation).	Review storage conditions. Ensure the compound is stored at the recommended temperature, protected from light and moisture. Re-evaluate the solvent used for storage if in solution, as some solvents can promote degradation.
Contamination.	Use high-purity solvents and clean labware. Filter solutions before injection into an HPLC system.	
Inconsistent experimental results	Degradation of the compound during the experiment.	Prepare solutions fresh before use. If the experiment is lengthy, consider the stability of the compound in the experimental medium. Protect the experimental setup from light if the compound is light-sensitive.
Inaccurate concentration due to degradation of stock solution.	Regularly check the purity of the stock solution using a stability-indicating analytical	

method like HPLC. Prepare fresh stock solutions at appropriate intervals.

Poor solubility after storage

Formation of less soluble degradation products or polymers.

Characterize the material to identify the impurity. If degradation is confirmed, the material may need to be repurified or a new batch obtained. Review and optimize storage conditions to prevent further degradation.

Frequently Asked Questions (FAQs)

Q1: What are the optimal storage conditions for solid **4,6-dimethyl-2-benzopyrone** for long-term stability?

A1: For long-term storage, solid **4,6-dimethyl-2-benzopyrone** should be stored in a tightly sealed, light-resistant container (e.g., amber glass vial) at a controlled low temperature, ideally at -20°C or below. To minimize oxidation, the container should be flushed with an inert gas like nitrogen or argon before sealing.

Q2: How stable is **4,6-dimethyl-2-benzopyrone** in solution?

A2: The stability of **4,6-dimethyl-2-benzopyrone** in solution depends on the solvent, pH, temperature, and light exposure. Coumarin and its derivatives are susceptible to hydrolysis of the lactone ring, particularly under basic conditions (high pH)[1]. It is recommended to prepare solutions fresh for each experiment. If a stock solution must be stored, it should be kept at a low temperature (e.g., -20°C) in a tightly capped, light-protected vial. Aprotic solvents are generally preferred over protic solvents for longer-term storage in solution.

Q3: What are the primary degradation pathways for **4,6-dimethyl-2-benzopyrone**?

A3: The main degradation pathways for coumarin-related compounds are photodegradation, hydrolysis, and oxidation.[2][3][4][5][6]

- Photodegradation: Exposure to UV and visible light can induce photochemical reactions, leading to the formation of various degradation products. Coumarins are known to be photosensitizers.[2][7][8]
- Hydrolysis: The lactone ring in the benzopyrone structure is susceptible to hydrolysis, which is accelerated by basic conditions, leading to the formation of the corresponding coumarinic acid (a cis-cinnamic acid derivative)[1].
- Oxidation: The aromatic ring and methyl groups can be susceptible to oxidation, especially in the presence of oxygen, heat, or trace metal ions. Oxidation can be a complex process leading to a variety of degradation products.[6]

Q4: How can I monitor the stability of my **4,6-dimethyl-2-benzopyrone** sample?

A4: A stability-indicating high-performance liquid chromatography (HPLC) method is the recommended approach to monitor the purity and degradation of your sample over time. This involves developing an HPLC method that can separate the intact compound from its potential degradation products. Forced degradation studies are used to generate these degradation products and validate the method's ability to resolve them.[9][10]

Q5: Are there any incompatible materials I should avoid when working with **4,6-dimethyl-2-benzopyrone**?

A5: Avoid strong oxidizing agents, strong bases, and excessive exposure to light. Additionally, be mindful of the potential for interaction with certain excipients if formulating the compound, as some excipients can contain reactive impurities like peroxides that can initiate oxidation.[6]

Quantitative Stability Data

The following tables provide illustrative data on the stability of a representative coumarin compound under various stress conditions. This data is intended to serve as a general guideline. Actual degradation rates for **4,6-dimethyl-2-benzopyrone** may vary.

Table 1: Stability of a Representative Coumarin Compound in Solid State

Condition	Duration	Assay (% of Initial)	Appearance
25°C / 60% RH (Ambient)	3 months	98.5%	No change
40°C / 75% RH (Accelerated)	3 months	92.1%	Slight yellowing
Photostability (ICH Q1B)	10 days	85.3%	Noticeable yellowing

Table 2: Stability of a Representative Coumarin Compound in Solution (Aqueous Buffer, 1 mg/mL)

pH	Temperature	Duration	Assay (% of Initial)
3.0 (Acidic)	25°C	24 hours	99.2%
7.0 (Neutral)	25°C	24 hours	98.8%
9.0 (Basic)	25°C	24 hours	87.5%
7.0 (Neutral)	4°C	7 days	97.1%

Experimental Protocols

Protocol 1: Stability-Indicating HPLC Method Development

This protocol outlines the steps for developing an HPLC method to assess the stability of **4,6-dimethyl-2-benzopyrone**.

1. Instrumentation and Columns:

- HPLC system with a UV detector.
- A C18 reverse-phase column (e.g., 4.6 x 150 mm, 5 µm) is a good starting point.

2. Mobile Phase Selection:

- Start with a simple mobile phase, such as a gradient of acetonitrile and water.
- Adjust the gradient and pH (using buffers like phosphate or acetate) to achieve good separation between the parent compound and any degradation peaks. A typical starting point could be a gradient from 30% to 90% acetonitrile over 20 minutes.

3. Forced Degradation Studies:

- Acid Hydrolysis: Dissolve the compound in a solution of 0.1 M HCl and heat at 60-80°C for several hours.
- Base Hydrolysis: Dissolve the compound in a solution of 0.1 M NaOH at room temperature for a few hours.
- Oxidative Degradation: Treat the compound with a solution of 3% hydrogen peroxide at room temperature.
- Thermal Degradation: Expose the solid compound to dry heat (e.g., 105°C) for 24-48 hours.
- Photodegradation: Expose the compound (both solid and in solution) to light according to ICH Q1B guidelines (e.g., 1.2 million lux hours and 200 W h/m²).
- Analyze samples from each stress condition by the developing HPLC method to ensure all degradation products are resolved from the main peak.

4. Method Validation:

- Validate the final HPLC method according to ICH guidelines for specificity, linearity, accuracy, precision, and robustness.

Protocol 2: Long-Term Stability Study

1. Sample Preparation:

- Aliquot sufficient quantities of solid **4,6-dimethyl-2-benzopyrone** into amber glass vials.
- For each storage condition, prepare at least three replicate samples for each time point.

- Flush the headspace of each vial with nitrogen or argon before sealing.

2. Storage Conditions:

- Long-term: $-20^{\circ}\text{C} \pm 5^{\circ}\text{C}$
- Intermediate: $5^{\circ}\text{C} \pm 3^{\circ}\text{C}$
- Accelerated: $25^{\circ}\text{C} \pm 2^{\circ}\text{C} / 60\% \text{ RH} \pm 5\% \text{ RH}$ and $40^{\circ}\text{C} \pm 2^{\circ}\text{C} / 75\% \text{ RH} \pm 5\% \text{ RH}$

3. Testing Schedule:

- Analyze samples at predetermined time points (e.g., 0, 3, 6, 9, 12, 18, 24, and 36 months for long-term storage).
- For accelerated studies, time points might be 0, 1, 3, and 6 months.

4. Analysis:

- At each time point, analyze the samples for appearance, assay (purity), and degradation products using the validated stability-indicating HPLC method.

Visualizations

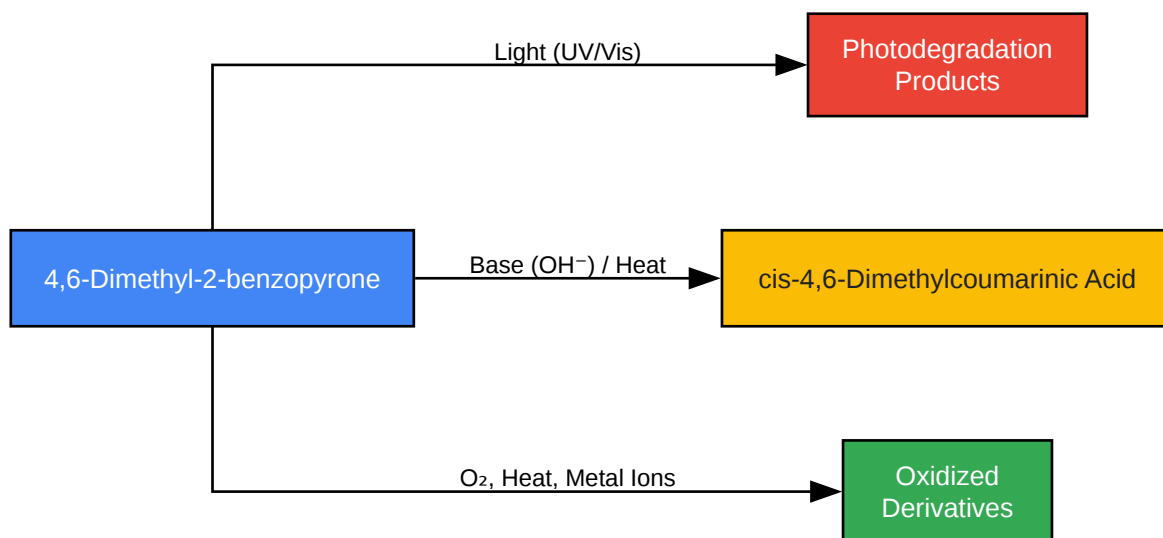

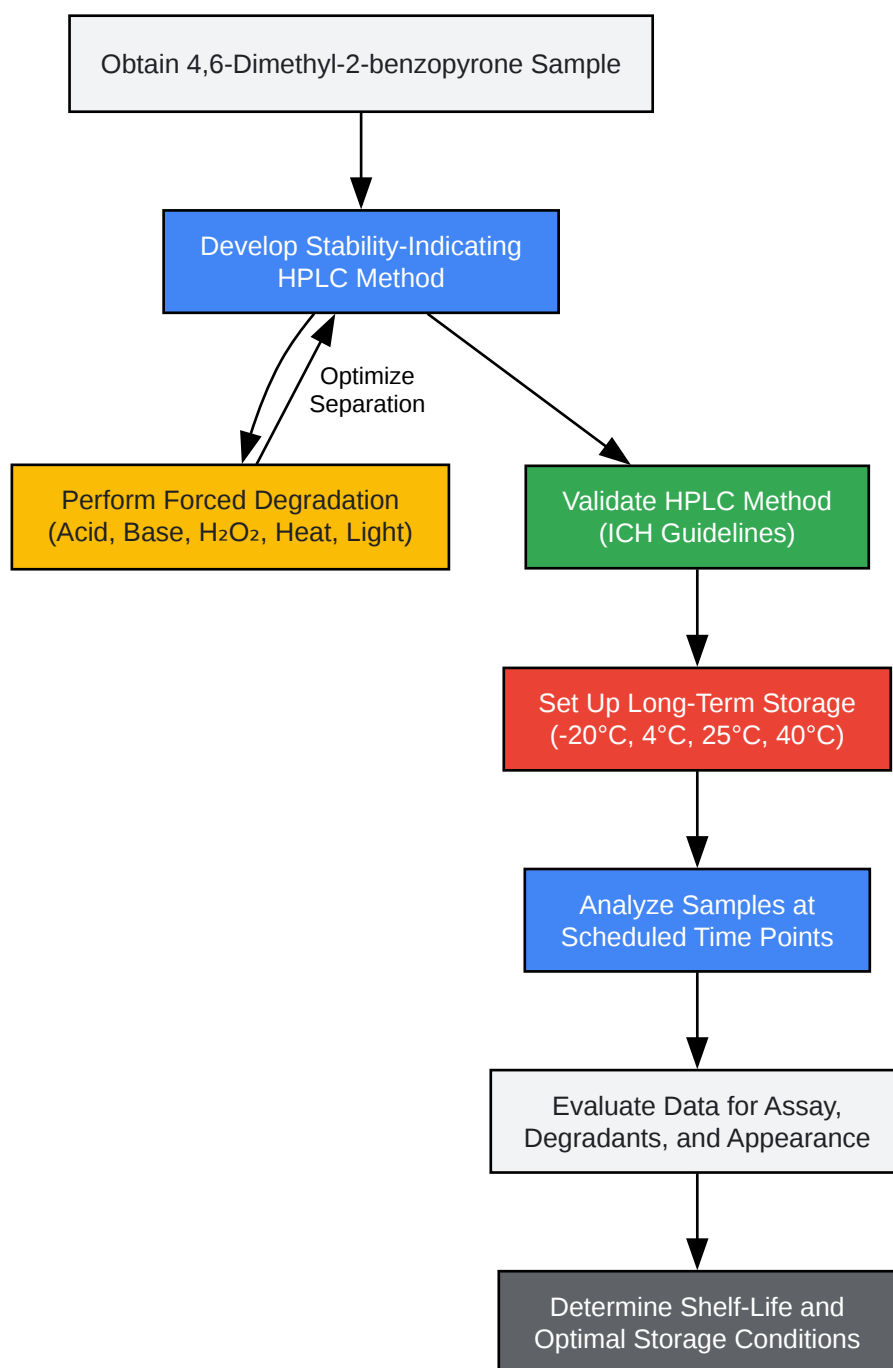

[Click to download full resolution via product page](#)

Need Custom Synthesis?

BenchChem offers custom synthesis for rare earth carbides and specific isotopic labeling.

Email: info@benchchem.com or [Request Quote Online](#).

References

- 1. Coumarin as a structural component of substrates and probes for serine and cysteine proteases - PMC [[pmc.ncbi.nlm.nih.gov](https://pubmed.ncbi.nlm.nih.gov)]
- 2. apps.dtic.mil [apps.dtic.mil]
- 3. Degradation Mechanisms of 4,7-Dihydroxycoumarin Derivatives in Advanced Oxidation Processes: Experimental and Kinetic DFT Study - PMC [[pmc.ncbi.nlm.nih.gov](https://pubmed.ncbi.nlm.nih.gov)]
- 4. Determination of aqueous stability and degradation products of series of coumarin dimers - PubMed [pubmed.ncbi.nlm.nih.gov]
- 5. Stabilization of Medicinal Agents Against Common Reactions like Hydrolysis & Oxidation | Pharmaguideline [pharmaguideline.com]
- 6. Oxidation of Drugs during Drug Product Development: Problems and Solutions - PMC [[pmc.ncbi.nlm.nih.gov](https://pubmed.ncbi.nlm.nih.gov)]
- 7. Photosensitization by coumarin derivatives - PubMed [pubmed.ncbi.nlm.nih.gov]
- 8. mdpi.com [mdpi.com]
- 9. Validated stability-indicating HPLC method for the determination of dimethyl-4,4'-dimethoxy-5,6,5',6'-dimethylene dioxybiphenyl-2,2'-dicarboxylate (DDB) and its degradation products - PubMed [pubmed.ncbi.nlm.nih.gov]
- 10. researchgate.net [researchgate.net]
- To cite this document: BenchChem. [Technical Support Center: Stabilizing 4,6-Dimethyl-2-benzopyrone]. BenchChem, [2026]. [Online PDF]. Available at: [<https://www.benchchem.com/product/b076538/docs#technical-support-center-stabilizing-4-6-dimethyl-2-benzopyrone>]

Disclaimer & Data Validity:

The information provided in this document is for Research Use Only (RUO) and is strictly not intended for diagnostic or therapeutic procedures. While BenchChem strives to provide accurate protocols, we make no warranties, express or implied, regarding the fitness of this product for every specific experimental setup.

Technical Support: The protocols provided are for reference purposes. Unsure if this reagent suits your experiment?

Need Industrial/Bulk Grade? [Request Custom Synthesis Quote](#)

BenchChem

Our mission is to be the trusted global source of essential and advanced chemicals, empowering scientists and researchers to drive progress in science and industry.

Contact

Address: 3281 E Guasti Rd
Ontario, CA 91761, United States
Phone: (601) 213-4426
Email: info@benchchem.com

[Contact our Ph.D. Support Team for a compatibility check](#)