

Application Notes and Protocols for the GC-MS Analysis of Sodium Arachidate

Author: BenchChem Technical Support Team. **Date:** April 2026

Compound of Interest

Compound Name: Sodium arachidate

CAS No.: 13257-34-6

Cat. No.: B076927

[Get Quote](#)

For Researchers, Scientists, and Drug Development Professionals

Introduction

Sodium arachidate, the sodium salt of arachidic acid (eicosanoic acid), is a saturated fatty acid found in various natural sources, including vegetable oils and animal fats. Its accurate identification and quantification are crucial in fields such as food science, nutritional analysis, clinical diagnostics, and drug development. Gas Chromatography-Mass Spectrometry (GC-MS) is a powerful and widely used analytical technique for the analysis of fatty acids.^[1] Due to their low volatility, fatty acids like arachidic acid require a derivatization step to convert them into more volatile esters, typically fatty acid methyl esters (FAMES), prior to GC-MS analysis.^{[1][2][3]}

This document provides detailed application notes and experimental protocols for the qualitative and quantitative analysis of **sodium arachidate** using GC-MS.

Experimental Protocols

A critical step for analyzing **sodium arachidate** by GC-MS is its conversion to the more volatile methyl arachidate.[1] This is typically achieved through an acid-catalyzed transesterification reaction.[1][4]

Protocol 1: Sample Preparation via Transesterification

This protocol outlines the conversion of **sodium arachidate** (or lipids containing arachidic acid) to methyl arachidate.

Reagents and Materials:

- Sample containing **sodium arachidate**
- Boron trifluoride-methanol solution (10-14% BF₃ in methanol) or 1.25 M HCl in anhydrous methanol[1][2][4]
- n-Hexane (GC grade)[1]
- Saturated sodium chloride (NaCl) solution[5]
- Anhydrous sodium sulfate (Na₂SO₄)[4]
- Screw-capped glass tubes[5]
- Heating block or water bath[5]
- Vortex mixer[4]
- Centrifuge[4]
- Glass Pasteur pipette[4]
- GC autosampler vials[1]

Procedure:

- Accurately weigh a known amount of the sample (e.g., 10-20 mg) into a screw-capped glass tube.[5]

- Add 2 mL of 10-14% BF₃-Methanol solution or 1.25 M HCl in methanol to the sample.[4][5]
- Seal the tube tightly and heat the mixture at 60-100°C for 10-90 minutes to ensure complete methylation.[2][5]
- Cool the tube to room temperature.
- Add 1 mL of n-hexane and 1 mL of saturated NaCl solution to the tube.[5]
- Vortex the mixture vigorously for 1 minute to extract the FAMES into the hexane layer.[4]
- Centrifuge the tube at a low speed (e.g., 1,000 x g) for 5 minutes to facilitate phase separation.[4]
- Carefully collect the upper n-hexane layer, which contains the methyl arachidate, using a glass Pasteur pipette.[4]
- Transfer the hexane extract to a clean vial containing a small amount of anhydrous sodium sulfate to remove any residual water.[4]
- Transfer the final dried extract into a GC autosampler vial for analysis.[1]

Protocol 2: GC-MS Instrumentation and Conditions

The following are typical GC-MS parameters for the analysis of methyl arachidate. These may need to be optimized based on the specific instrument and column used.

Parameter	Recommended Setting
Gas Chromatograph	Agilent 6890N or similar[1]
Mass Spectrometer	Agilent 5975C MSD or similar[1]
GC Column	DB-5MS (30 m x 0.25 mm x 0.25 µm) or similar non-polar column[1]
Carrier Gas	Helium at a constant flow rate of 1 mL/min[1][5]
Injection Volume	1 µL[1]
Injector Temperature	250°C[5][6]
Injection Mode	Splitless or Split (e.g., 1:50)[1][7]
Oven Temperature Program	Initial temperature of 70°C for 2 min, ramp at 5°C/min to 240°C, hold for 5 min[1]
Transfer Line Temp.	240°C[1]
Ion Source Temp.	230°C[1]
Quadrupole Temp.	150°C[1]
Ionization Energy	70 eV (Electron Ionization - EI)[1][8]
Mass Scan Range	m/z 50-600[5]
Solvent Delay	Dependent on solvent elution time

Data Presentation

The identification of methyl arachidate is based on its retention time and the resulting mass spectrum. The following table summarizes the key quantitative data for the identification of methyl arachidate.

Parameter	Value	Reference
Molecular Formula	C ₂₁ H ₄₂ O ₂	[9]
Molecular Weight	326.6 g/mol	[10]
Retention Time (approx.)	10.344 min (Varies with conditions)	[1]
Key Mass Spectral Fragments (m/z)	326 (M ⁺), 297, 285, 243, 199, 143, 87, 74	[1][10]

Visualizations

Experimental Workflow

The following diagram illustrates the logical workflow for the GC-MS analysis of **sodium arachidate**.

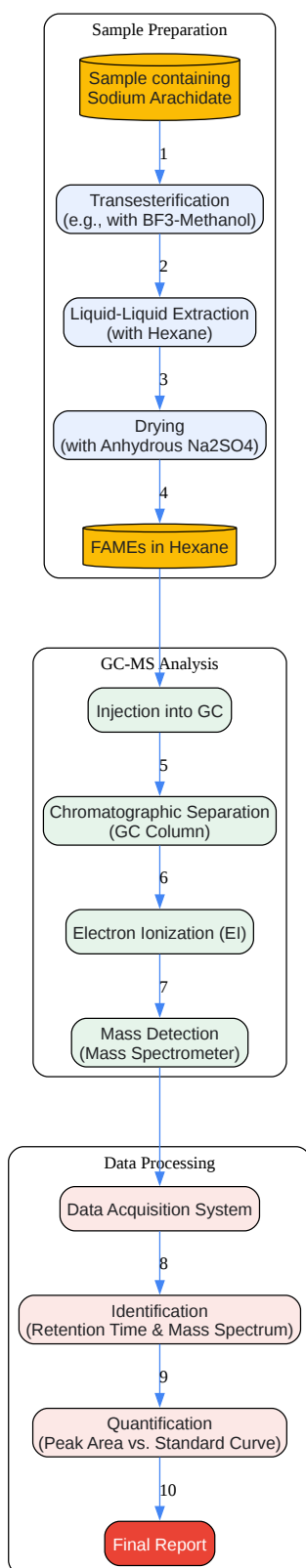

[Click to download full resolution via product page](#)

Caption: Workflow for GC-MS analysis of **sodium arachidate**.

Mass Fragmentation Pathway

The following diagram illustrates a simplified fragmentation pattern for methyl arachidate in an EI-MS source.

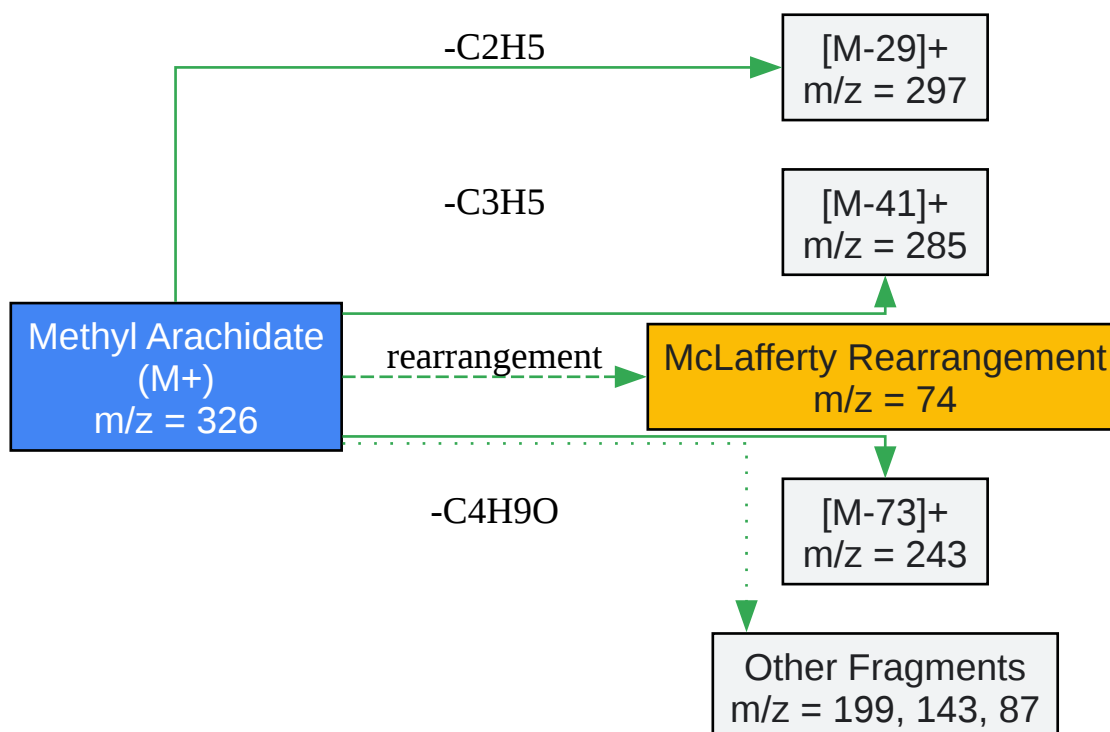

[Click to download full resolution via product page](#)

Caption: Fragmentation of methyl arachidate in EI-MS.

Need Custom Synthesis?

BenchChem offers custom synthesis for rare earth carbides and specific isotopic labeling.

Email: info@benchchem.com or [Request Quote Online](#).

References

- 1. benchchem.com [benchchem.com]
- 2. benchchem.com [benchchem.com]
- 3. High Sensitivity Quantitative Lipidomics Analysis of Fatty Acids in Biological Samples by Gas Chromatography-Mass Spectrometry - PMC [pmc.ncbi.nlm.nih.gov]

- [4. benchchem.com \[benchchem.com\]](#)
- [5. benchchem.com \[benchchem.com\]](#)
- [6. researchgate.net \[researchgate.net\]](#)
- [7. academicjournals.org \[academicjournals.org\]](#)
- [8. chempap.org \[chempap.org\]](#)
- [9. Eicosanoic acid, methyl ester \[webbook.nist.gov\]](#)
- [10. Methyl arachidate | C21H42O2 | CID 14259 - PubChem \[pubchem.ncbi.nlm.nih.gov\]](#)
- To cite this document: BenchChem. [Application Notes and Protocols for the GC-MS Analysis of Sodium Arachidate]. BenchChem, [2026]. [Online PDF]. Available at: [\[https://www.benchchem.com/product/b076927/docs#application-notes-and-protocols-for-the-gc-ms-analysis-of-sodium-arachidate\]](https://www.benchchem.com/product/b076927/docs#application-notes-and-protocols-for-the-gc-ms-analysis-of-sodium-arachidate)

Disclaimer & Data Validity:

The information provided in this document is for Research Use Only (RUO) and is strictly not intended for diagnostic or therapeutic procedures. While BenchChem strives to provide accurate protocols, we make no warranties, express or implied, regarding the fitness of this product for every specific experimental setup.

Technical Support: The protocols provided are for reference purposes. Unsure if this reagent suits your experiment?

Need Industrial/Bulk Grade? [Request Custom Synthesis Quote](#)

BenchChem

Our mission is to be the trusted global source of essential and advanced chemicals, empowering scientists and researchers to drive progress in science and industry.

Contact

Address: 3281 E Guasti Rd

Ontario, CA 91761, United States

Phone: (601) 213-4426

Email: info@benchchem.com

Contact our Ph.D. Support Team for a compatibility check